

RESHYVENT

Cluster Project on Demand Controlled Hybrid Ventilation in Residential Buildings with Specific Emphasis on the Integration of Renewables

Contract No: ENK6-CT2001-00533

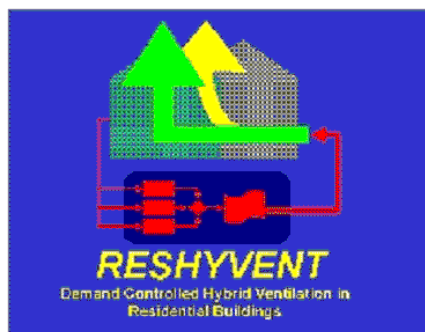

Report Title:

State-of-the-art of low-energy residential ventilation

RESHYVENT Report No: RESHYVENT-WP1-R1 (2002-11-13)

RESHYVENT Work Package: WP1, State-of-the-art

Status: Working draft report for internal use within RESHYVENT

Edited by:

Dr. Peter G. Schild, Norwegian Building Research Institute (NBI)

Contributions by:

Cauberg-Huygen Raadgevende Ingenieurs BV (CHRI, Netherlands). Netherlands Organisation for Applied Scientific Research (TNO, Netherlands). Belgium Building Research Institute (BBRI, Belgium). Swiss Laboratories for Materials Testing and Research (EMPA, Switzerland). AB Jacobson & Widmark (J&W, Sweden). Centre Scientifique et Technique du Bâtiment (CSTB, France). Esbensen Consulting Engineers (Denmark). Instituto de Engenharia Mecânica (IDMEC, Portugal). National and Kapodestrian University of Athens (NKUA, Greece). LHG Kanalfläkt AB (Sweden), Wetterstad Consulting AB (Sweden). Stigberget Driftteknik AB (Sweden). Industrie en Handelsmaatschappij Bergschenhoek BV (IHB, Netherlands). Aluminium Handelmij Alusta BV (Alusta, Netherlands). J.E. Stork Ventilatoren BV (Stork, Netherlands). Cox Geelen BV (Cox, Netherlands). Aereco SA (France). Renson NV (Belgium). Flexit AS (Norway). Gaia Solar (Denmark). Brno University of Technology (BUT, Czech rep.). Aalborg University (Denmark)

CONTENTS

1	OVERVIEW	3
1a	Residential ventilation in Europe today	3
1a.1	System types.....	3
1a.2	Regional & climatic influences	5
1a.3	Building types: Facts and figures	6
1a.4	Earlier field studies of residential ventilation	6
1b	Challenges, attitudes, trends and targets	6
1b.1	Challenges facing tomorrow's residential ventilation.....	6
1b.2	Technological trends, market forces and potential.....	7
1b.3	Energy technology indicators – Present and potential target values.....	8
2	REQUIREMENTS AND RECOMMENDATIONS FOR GOOD VENTILATION.....	10
2a	Creating a satisfactory indoor environment.....	10
2a.1	Air quality	10
2a.2	Climatisation.....	12
2a.3	Noise	14
2a.4	Design process - integrated design approach, with examples	17
2b	Operational qualities of ventilation systems	22
2b.1	Operation & maintenance	22
2b.2	Health & safety	33
2b.3	Space and location issues	34
2b.4	Economic impact of ventilation systems.....	35
2b.5	Environmental impacts of ventilation.....	36
3	ENERGY-CONSCIOUS VENTILATION TECHNOLOGY	38
3a	Energy-efficient ventilation principles & components	38
3a.1	Minimise air change rate, i.e. minimise ventilation flow rate needed for air quality and cooling:.....	38
3a.2	Minimise energy needed to condition required supply air	50
3a.3	Minimise fan power.....	53
3a.4	Efficient controls - What is the state-of-the art and trends in controls?:.....	64
3a.5	Behavioural incitement to energy-efficiency:.....	75
3b	Replacement with renewables.....	76
3b.1	What necessary support energy is needed ?.....	76
3b.2	Integration of renewables.....	77
3b.3	Solar power (IEA SHCP task 19, 20; IEA PVPS; EU Joule).....	79
3b.4	Wind power	96
3c	Maximizing primary energy conversion efficiency	99
4	PERFORMANCE ASSESSMENT	100
4a	Performance assessment (Local or personal impact)	100
4a.1	Comfort, health, safety & technical performance	100
4a.2	Financial assessment	108
4b	Environmental assessment (Global/regional societal impact)	109
4b.1	Principles of environmental assessment.....	109
4b.2	Software/tools	109
5	FURTHER READING : A LIST OF SOURCES	112

1 OVERVIEW

1a Residential ventilation in Europe today

1a.1 System types

- different practices for:
 - climatisation
 - air distribution
 - driving forces (natural, forced, hybrid)
 - state exactly what is hybrid ventilation, what it isn't ? not to be confused with building-integrated design
 - Different classifications (characterization) of hybrid ventilation systems - Focus on the specific topics of residential buildings
- How much of the market is held by each of the competing types of ventilation systems today?
 - Statistics for different countries: natural, exhaust, balanced vent.

Ventilation is of major importance for the well-being of people in their homes. The two main purposes of ventilation are to obtain an acceptable indoor air quality and to avoid degradation of the building fabric e.g. rot in wood, rust on steel. As to indoor air quality the occupants' sensitivity can vary across a wide range from an allergic infant to a well trained sportsman, from an active person spending most of the time outdoors to an elderly person confined to a life indoors (IEA ECBS Annex 27 Handbook Evaluation and Demonstration of Domestic Ventilation Systems, 2002). During the lifetime of a building, its occupancy pattern also varies.

Today there are a wide variety of different ventilation strategies in the different European countries. In some countries the only ventilation is uncontrolled air infiltration and window airing, while in others passive stack ventilation systems are more or less in common use. In countries with colder climates, mechanical systems have been installed in new buildings since the seventies, in particular in the Nordic countries. The systems are either exhaust only or balanced, with or without heat recovery units. Apart from northern Europe the dominating European ventilation system is natural ventilation.

The natural ventilation systems are driven by wind and thermally (stack) generated pressures. Designing for natural ventilation is concerned with harnessing these forces by the careful sizing and positioning of openings (Martin Liddament, A Guide to Energy Efficient Ventilation, AIVC, 1996).

The natural ventilation components used in Europe are:

- Openable windows and louvers, which in many buildings are the main component of natural ventilation. They permit the passage of large air flows for purging or summer cooling, but might cause energy waste during the heating season.
- Air vents and "trickle" ventilators, which can ensure that unnecessary ventilation can be avoided during winter. One vent per room is typically recommended. They are often located above the window or integrated into the window frame. Sometimes ventilators are located directly behind wall mounted radiators in order to avoid draft during winter.
- Automatic (variable area) inlets, which respond automatically to various air quality and climate parameters. They are not yet widely used, due to high costs.
- Passive stacks, which are vertical ducts from e.g. bathrooms and kitchens to above roof level. The purpose is to enhance temperature difference or stack driven air flow.
- Air vents for combustion appliances, which secure combustion supply air to an open combustion appliance.

Mechanical ventilation can provide controlled ventilation to a space.

Mechanical ventilation components used in Europe are:

- Fans, which provide the motivating force for mechanical ventilation.

- Ducts, which transfer air. Ducts impose a resistance to air flow, thus influencing performance and energy use.
- Diffusers, which discharge mechanically supplied air into ventilated spaces.
- Air intakes, which are the openings where outdoor air is ducted to a ventilation system.
- Air inlets, which are passive openings for providing air to a space.
- Air grilles, which capture exhaust air from a space.
- Silencers (noise attenuators), which dampen the noise from the ventilation system and noise being transferred through the ventilation system.

1a.1a Classification of hybrid ventilation systems

Hybrid Ventilation is a two-mode system, which is controlled to minimise the energy consumption while maintaining acceptable indoor air quality and thermal comfort. The two modes refer to natural and mechanical driving forces.

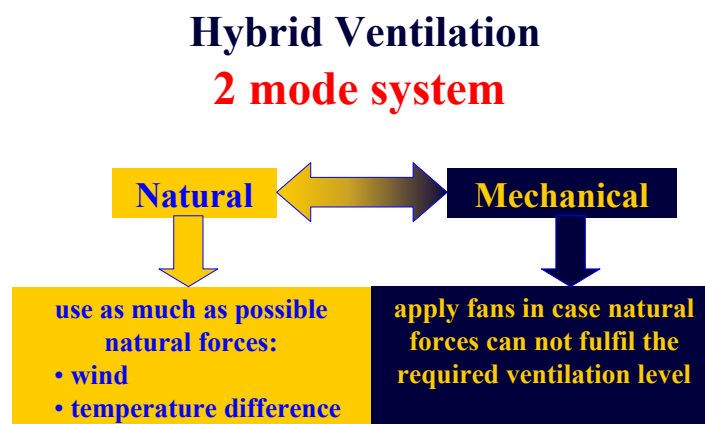

Figure 1 Schematic picture of hybrid ventilation

Three hybrid ventilation concepts can be defined:

- alternate use of natural and mechanical ventilation
- fan assisted natural ventilation
- stack and wind supported mechanical ventilation.

All buildings with hybrid systems up till now are far from what might be the optimum solution. There is a knowledge gap especially on dimensioning and control of hybrid ventilation systems. The remaining challenges and unsolved problems for hybrid ventilation are briefly described.

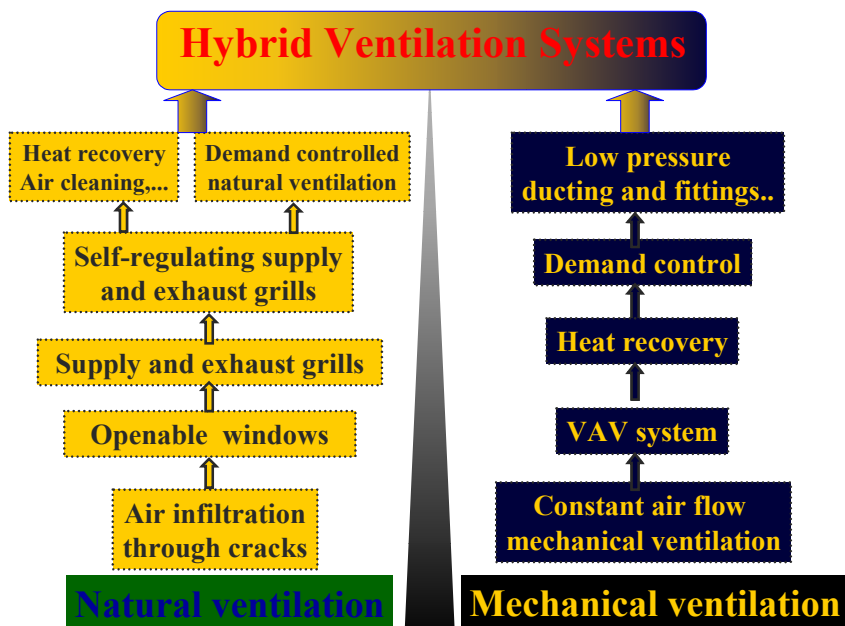

Figure 2 Recent developments in ventilation systems

More information may be found in [1].

In the development of hybrid systems the following aspects may play an important role:

- local exhaust versus central exhaust
- tuning supply and exhaust
- self controlled air inlets
- low pressure ducting supported by wind and buoyancy
- demand control
- optimal dimensioning

1a.2 Regional & climatic influences

- Description of climatic zone types, and the main goals of dwelling ventilation and climatisation of dwellings in each
- What ventilation principles & systems are used in the different countries (natural/exhaust/balanced etc.) ?

Climatic zones in East Europe – CZ, H, PL

There is mainly continental humid climate, characterized by differences between winter and summer temperatures. The main goal of dwelling ventilation and climatisation is air exchange for IAQ, combustion, and summer cooling.

Table 1 Average temperatures in climatic zone

State	Average winter temperature	Average summer temperature	Average annual temperature
Czech republic	-9°C and 0°C	23°C and 29°C	5.5°C and 10°C
Poland	-5°C and 0°C	17°C and 20°C	7°C and 8°C
Hungary	0°C and 4°C	23°C and 28°C	6°C and 11°C

Ventilation principles and systems

Dwelling ventilation is mostly NWA type – Natural Window Airing – (qualified guess 99%), kitchen hoods in 80% dwellings. Air conditioning (climatisation) is very rare, if any then portable A/C devices either with thermodynamic compressor cycle or by evaporation of water.

1a.3 Building types: Facts and figures

- Statistics on size & breakdown of dwelling stock (detached, flats, etc)
- OECD energy figures for ventilation losses and for electricity use of fans etc. & environmental impact
- New buildings contra retrofit
- Changing patterns of use and changes in society and commerce, e.g. mobile office, factory automation

Changing patterns

In the developed countries people spend between 80 and 90% of time indoors (surveys in the US in early 90's showed that people aged 12 and older spent 87-89% time indoors). The survey carried out in Canada in 1998 showed that people (aged 15 and over) spent in average more than 16 hours a day at home (average over a 7-day week). These results make obvious the importance of IAQ and residential ventilation.

The number of people per dwelling in Europe decreases (in 2001 - Czech Republic 2.67, Norway 2.3, United Kingdom 2.4). The percentage of one-person households increases (in 2001 - Norway 37 %, United Kingdom 29%). The one-occupant dwellings are not occupied for the considerable part of the day since the occupants go out for work, shopping, leisure activities, etc.

The percentage of people aged 65 and older in EU countries increases (12% in 1970, 17% in 2001, in the Czech Republic 13.8% in 2001). The retirees spent in average more time at home than the employed people.

The unemployment rate in EU countries in June 2002 was 8.4 percent. The unemployed people spend generally more time at home than the employed once.

People in Europe spent most of their free time at home. The most common leisure activity is watching television (in average more than 2 hours/day).

1a.4 Earlier field studies of residential ventilation

- There are some nordic studies (air flow rate, CO₂, energy consumption)
- Netherlands study, Annex 27 study
- Other studies ?

1b Challenges, attitudes, trends and targets

1b.1 Challenges facing tomorrow's residential ventilation

- Issues: urbanization (traffic/pollution/heat island), energy prices, changing climate, environmental pollution (materials recycling, asthma), globalisation affecting industry, etc. Other societal challenges, attitudes and targets.
- Building certification in EU; harmonizing EPR, standardization, certified testing, control (e.g. Sweden, Airtightness in Germany), need for regulations.

Nowadays, the situation regarding to ventilation vary largely across Europe. Standards are different from country to country. Ventilation systems are largely applied in some countries (e.g. The Netherlands), but have some difficulties to be (correctly) implemented in others (e.g. Belgium). This should change in the future, under the pressure of 1) European standardization and 2) Energy Performance Regulations (EPR).

- 1) The CEN TC 156 produces new European standards about ventilation in buildings (both residential and non residential buildings). In January 2003, about 30 new documents were under development or under approval phase. All the approved standards have automatically to be translated in national standards in each European country, and existing standards that are in conflict have to be removed. This has an influence on the work of the ventilation sector.

For more information, visit www.cenorm.be > Standardization > Technical Bodies > CEN Technical Committees.

The document "Opportunities, barriers and challenges in relation to the application of standards and regulations on hybrid ventilation systems" from WP4 gives a good overview of challenges related to standardization.

- 2) In 2002, the "Energy Performance of the building Directive" (EPD) was adopted by the Commission and the Parliament. This Directive obliges all member states to adopt EPR before 2006. As the EP of a building includes the energy for ventilation and infiltration, this has an impact on the way buildings are designed and constructed.

In a few words, the designer has to evaluate the total (standardised) energy performance of his building. If it is above a limit, he will have to improve his design. This can be done by improving any building element/system: one can choose to have a better insulation, or a better lighting system, or a better ventilation system... Therefore, ventilation systems will not be in competition with each others only, but also with other building technologies. The ones that can give a low EP coefficient should be largely used.

For more information about EPR, visit (e.g.) www.enper.org.

They two aspects should improve the situation in countries where ventilation is not (correctly) applied. If they are not enough, more strict regulations should come into force. Indeed, experiences in some countries have shown that it is technically possible to design, installed and maintain efficient systems, so far that there is a (political) willingness to do it (e.g. duct airtightness and Boverket procedure in Sweden).

1b.2 Technological trends, market forces and potential

- How will the above boundary conditions affect the choice of most optimum ventilation system?
 - Increasing use of heat recovery and more efficient fans, especially in countries with EPR
 - Mention what motivations there are for going further, to hybrid systems
 - What is the market potential & attitudes to hybrid systems ?
 - Increasing building-integration of ventilation systems
- Mention trends & potentials of the electronic age: Domotica, power management, demand-control etc.
- Implications of increasing building energy-efficiency on ventilation system design:
 - "low energy buildings" which have high levels of insulation etc - the heating demand is lower, internal heat gains are enough alone for climatisation. ventilation heat loss will become increasingly important (larger portion of building's total energy use) also summer cooling becomes more important (due to reduced transmission losses).
 - Increasingly passive design approach, shift in international attitudes
 - mention "Passivhaus" technology, increasingly integrated/holistic design solutions:
 - Have only a ventilation system with integrated air heating (at hygienic flow rates, no recirculation for additional heating)
 - Also the use of a single unit for ventilation, air heating and hot water preparation and storage) is quite common
 - The impact of ventilation of other low exergy concepts (The work of IEA Annex 37 "Low exergy")

Hybrid ventilation and hygro-controlled ventilation are well developed in France ; about several ten thousands (dwellings) for hybrid ventilation and about several hundred thousands (dwellings) for hygro-controlled ventilation.

1b.3 Energy technology indicators – Present and potential target values**Table 2a** Energy technology indicators for residential ventilation [NBI]

ISSUE	INDICATOR	PRESENT 2002	TARGET 2010
A. Global indicators for ventilation technology			
1. GHG emissions & climate change	CO2 emission due to ventilation Mton/y in EU	153 (year 2001)	149.4 (year 2017)
2. Social indicators : Production employment in ventilation industry			
B. Ventilation performance			
1. Minimum ventilation air flow rates for IAQ	CO2 concentrations [kppm·h] CO2 hours over 700 ppm CO2 hours over 1400 ppm	2000 500	500 100
2. Noise	Indoor noise level from mechanical ventilation equipment	> 35 dBA	bedroom: < 25 dBA living areas: < 30 dBA 'wet' rooms: < 35 dBA
C. Replacement with renewables			
	Percent of total delivered energy for ventilation from renewables	< 5%	?
1. Integrate solar energy	Delivered solar energy (e.g. PV)		
1a. Solar energy for air transport			
1b. Solar energy for conditioning supplied air			
2. Integrate wind energy	Exploitation of wind. Average percent of transporting energy provided by wind (wind-augmented)	< 5%	new bldgs: > 10% (2015)
3. Other delivered renewables			

Table 2b Energy technology indicators for residential ventilation, contd. [NBI]

ISSUE	INDICATOR	PRESENT 2002	TARGET 2010
D. Energy-efficient ventilation technology	Delivered energy for ventilation (various indicators can be used, ideally GJ/person for dwellings, and GJ/m ² for tertiary) severe climate cold climate moderate climate mild climate warm climate	GJ/dwelling 43 severe 33 cold 22 moderate 9 mild 5 warm	GJ/dwelling 7.5 severe 5.8 cold 4.9 moderate 1.2 mild 0 warm
1. Minimize ventilation air change rate			
1a. Source control			
1a1. Indoor Air Quality, IAQ (i.e. chemical)	- Environmental tobacco smoke - Indoor respiratory particulates PM2.5	smoke exposure > 1000 hours	smoke exposure < 400 hours
1a2. Climatisation (i.e. thermal)	e.g. Average internal heat gains from electrical equipment & lighting		
1b. Ventilation efficiency	Average total-system net contaminant removal efficiency, accounting for all recirculation paths in system (ventilation efficiency. 100% is equivalent to fully mixed)	<100%	>110%
1b1. Spatial efficiency			
1b1a. Ventilated area per person	Ventilated area per person	?	< 20 m ²
1b1b. Displacement ventilation	Market penetration of displacement vent (including cascade ventilation)	< 5 %	> 25%
1b1c. Minimise short circuiting			
1b1c1. Duct airtightness	Average duct airtightness (Eurovent class. Class A is worst)	existing bldgs < A but new bldgs ~A	B
1b1c2. Building airtightness			
1b2. Temporal efficiency			
1b2a. Demand-controlled ventilation	Utilisation of potential annual reduction air exchange relative to continuous ventilation (CAV); window opening excluded	< 5%	new bldgs: > 20%
2. Minimize energy use for conditioning required supply air (i.e. to offset ventilation loss/gain, not space heating/cooling)			
2a. Preheating	- Energy to air preconditioning (refrigeration) kWh/degreeday over 20°C per person or m ²		
2a1. Ventilation heat recovery	-Percent retrofit existing buildings -Percent of new buildings -Typical net heat recovery efficiency for ventilation unit	< 5% < 10% 40~75%	> 15% > 90% > 70%
2b. Precooling	- Energy to air preconditioning (refrigeration) kWh/degreeday over 28°C per person or m ² - Percent cooling demand provided by "passive means" or "ambient energy"		
2c. Infiltration heat loss/gain			
3. Minimise energy for transporting air, i.e. fan energy	Specific Fan Power, SFP [kW/m ³] VAV = variable air operation, 11h/day CAV = continuous operation 24h/day	balanced vent: 2.7	Target 2005: 1.5 Target 2020: 0.75
3a. Fan efficiency	Secondary target: Total fan system efficiency, η _{tot}	?	Target 2005: 0.2 Target 2020: 0.3
3b. Low pressure drop components	Secondary target: Total pressure drop for air path through bldg (incl. internally in air handling unit, AHU), [Pa]	balanced vent: > 300	Target 2005: 300 Target 2020: 225
4. Efficient controls			
4a. Sensor / actuator / communications technology			
4b. Control strategies technology	Air flow stability, % of time according to design or demand	6- 12 % (poor)	25-50% (good)
5. Behavioural incitement to save energy			
5a. Design features that reduce behavioural energy wastage	Percentage of apartment blocks that have individual heating energy metering in each apartment	< 5%	> 10%

2 REQUIREMENTS AND RECOMMENDATIONS FOR GOOD VENTILATION

This chapter is based on a thematic list of qualities that a ventilation system must have:

2a Creating a satisfactory indoor environment

The aspects of the indoor environment that can be influenced by ventilation have been systematised in Figure 3. This pyramid can be likened to Maslow's hierarchy of human needs, where the basic physiological needs must first be met, before addressing the luxury of psychosocial needs (such as aesthetics). All of the 5 human senses (that constitute the 'physiological environment') are influenced by ventilation. Further, many aspects of the psychosocial sphere are heavily influenced by ventilation, such as the need to control one's environment, pleasure experienced by dynamic stimuli (e.g. changing draft in hot weather), etc.

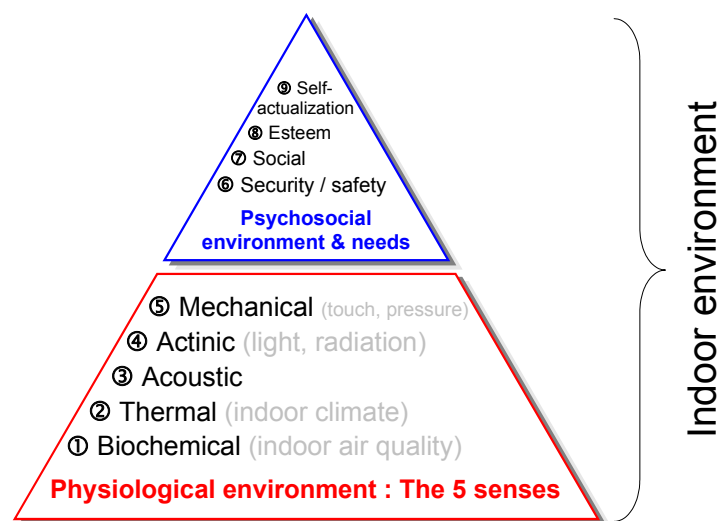

Figure 3 The indoor environment: A hierarchy of human constraints for a ventilation system, based on the different forms and levels of human needs and experience

2a.1 Air quality

- What is air exchange needed for?
 - different types of need for fresh air and contaminant removal (combustion, respiration etc.)
 - air pollution in an urban environment
- What minimum fresh air exchange rate do we need ?
 - Building regulations on flow rates: What is happening in different countries ?
 - maybe a net decipol or "mean age of air" concept or ppm-CO2 can be used for each occupied zone instead of flow rate requirement ?
 - What do building regulations / EPC say about this ?
e.g. Swiss Standard SIA 180: flow rates have to be defined in relation to occupancy, internal pollution load, and moisture level.
 - Maybe direct flow rate requirements are acceptable as fall back option, in cases where occupant/pollutant/moisture loads not known
 - Can infiltration be considered as part of design flow rate?
 - Under which conditions is this permissible (should not contradict aforementioned recommendation for building airtightness) ?

- Charts showing infiltration for buildings with natural, exhaust, balanced vent (different degrees of imbalance)
 - For extract systems, infiltration is an especially important consideration.
 - (a) for ventilation loss calculation,
 - (b) for the total extract flow rate (sum of infiltration and flow through supply openings).
 - (c) for distribution of fresh air. e.g. opening a window punctures the whole building, and rooms on or above the neutral axis don't get fresh air
 - Ventilation efficiency : do regulations allow exploitation of its pull potential ?
 - The issue of IC1 on how circulation zones are handled in terms of required flow rates (cascade flow)
 - Finally, summary of recommendations on requirements & interpretation of building codes.
- Humidity
 - problems with too damp air, and too dry air in winter. When is moisture recovery appropriate?
- Filtration
 - Practices in different countries. Regulations and interpretation
 - under what circumstances is it needed. There is evidence that it reduces air quality.

2a.1a What is air exchange needed for?

There are several reasons why a supply of fresh air is needed in residential buildings. The most important reason is respiration. All living creatures need air in order to live. Normal resting adult respiratory rate is around 12 breaths/minute. The mean breathing volume is around 10 l/min for adult males (when sitting). However, some studies show that even at rest or at very light work, peak flows approaching 200 l/min are common — especially when speech is introduced.

Another reason why air exchange is needed is contaminant control. The human body itself is a source of air pollutants (CO₂, water vapor, odors). Besides, there are usually other pollutants present in residential buildings (dust, VOCs, tobacco smoke, etc.). The concentration of the contaminants has to be kept below the certain level, by air exchange, to achieve satisfactory IAQ and healthy environment.

Combustion – a supply of fresh air is needed for both unvented and vented combustion appliances. The unvented appliances (gas cookers, gas ovens) do not vent to the outside, and so they release combustion pollutants directly into the home. The vented appliances (stoves, fire places, furnaces, etc.) depend on using house air to make-up for the air going up the flue.

2a.1b What minimum fresh air exchange rate do we need ?

It is quite obvious that there is a link between IAQ and comfort. However, a “mathematical” relationship between IAQ and health effects, that could be used to determine the “optimal” airflow, has not been established definitively. (Some studies suggest that airflow rate should never be less than 10 l/s.person.)

Therefore, the national standards and regulations are mostly based on national practice and differ very much from countries to countries.

The airflow rates required by the different regulations can be expressed in fixed rates (m³/h or l/s), rates per surface (m³/h.m²), rates per person (m³/h.person), or air change (1/h). The minimal requirements vary from less than 0.5 h⁻¹ to @1.4 h⁻¹.

Some regulations also expressed the requirements in term of maximum pollutant concentrations. The most common pollutant is the CO₂, as it reflects very well the human occupancy. However, as CO₂ sensors are still expensive, their use in dwellings seems limited and CO₂ based strategies seem more applicable to office buildings. Another pollutant is relative humidity, which reflects both human occupancy and activities in dwellings (cooking, bath...).

Some countries require a minimal airflow, even when there is no occupant, in order to remove the pollution emitted by the building itself.

A survey of standards and regulations can be found in the report "Opportunities, barriers and challenges in relation to the application of standards and regulations on hybrid ventilation systems" (WP4).

Regulations related to air quality

- Infiltration has clearly an impact on the performances of a ventilation system. It can increase the air flow rates through the rooms, which increases the heating demand. The efficiency of a heat recovery unit may also be affected, if the supplied and extracted air differ due to infiltration.

It can also alter the designed airflow pattern, especially in case of natural ventilation. This can decrease the indoor air quality.

Infiltration is not the only (or the main) cause of disturbance. Users can have a higher impact if they open windows (or doors), which can totally change the pressure conditions inside the building and prevent air to enter/exit some of the rooms.

- Most of national standards do not address ventilation efficiency intensively, although it can have an important impact on the IAQ.

Belgium: The standards states that "air inlets/outlets are positioned so that they ensure a suitable sweeping of the room."

Sweden*: "The air change efficiency is recommended to be not less than 40 %."

Germany*: "This is done by general demands on the indoor climate (operative temperature, air quality, air moisture, velocity, pollution and ventilation efficiency)"

*: see report WP4.1

- Standards and regulations are only a minimum set of requirements, corresponding to "normal" conditions. A system that complies with all of them shall not necessary provide a good IAQ. As the market is mainly driven by the price, there is a risk that these minimum set of requirements becomes also the only set of requirements. Therefore, higher the quality of the standard, higher the quality of the system.

2a.1c Air filtration

In areas without any particular contamination loads in the outdoor air, the filtration may be considered to be unnecessary. In areas with heavy traffic or with industrial air contamination filtering will be necessary.

Some studies show that with average relative humidity, RH, higher than 80 % for three days there is a risk of microbial growth in the filter and in the ventilation system. As it is in many cases difficult to avoid high relative humidity, filtering should take place in two steps. The first filtration step should be carried out using a filter of at least F7 quality (80% dust spot efficiency according to EN779) and the second step with a filter of at least F7-quality, which is not exposed to high RH and effectively stops micro-organisms and particles.

Regulations related to filtration

ASHRAE Standard 62-2001

Ducted supply systems and the central air handler must meet minimum filtration efficiency of 60% for 3 micron particles.

2a.2 Climatisation

- Requirements: Building regulations / RESHYVENT recommended targets
- developments on thermal comfort theory (e.g. adaptive thermal comfort)
- heat island and urban canyon effects
- draft risk from cold air downdraft at windows/vents/displacement vent.

Even if its first aim is to provide a good IAQ, ventilation has an impact on thermal comfort too. Therefore, this has to be taken into account when designing a ventilation system.

Thermal comfort includes the three aspects: temperature (operative temperature), relative humidity and draught. "Mathematical" relationships between those parameters and the perceived thermal comfort have been extensively analysed and are well established – even if they are now called in question (see below). These relations have been established by (Fanger, 1972) and can be found in EN ISO 7730.

Requirements: Building regulations / RESHYVENT recommended targets

[WP5-WR-2]

Upper and lower temperature limits (air temperature or operative temperature) in function of outdoor conditions are given in many standards and regulations.

Examples are: ASHRAE 55-92 (USA), DIN 1946-2 (German standard) , SIA 382/2 (Swiss standard, see figure). The threshold values are defined by a figure with limits for operative temperature (1h mean value during occupied time) in function of outdoor air temperature (maximum 1h mean value of the day).

The temperature limits are not identical to the design temperature target values.

The temperature limit figures may be established according to the different climatic regions.

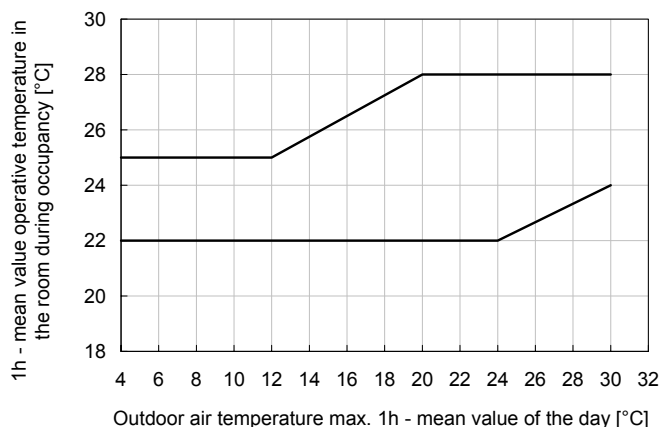

Figure 4 Temperature limits for moderate climate

In RESHYVENT a maximum of 50 Kh above the defined threshold values is recommended. (Cases with Ta max > 30 °C are not considered)

Draught risk

Cold surfaces influence the thermal comfort of room occupant by radiation and by convection.

Radiation: the human body radiates heat to the cold surface. This leads to a sensation of cold.

Convection: the air close to the window cools down and become heavier. This creates an air movement: warm air comes close to the windows, cools down... The air movement can create a draught, which may cause discomfort.

It is therefore necessary to maintain the room surfaces, especially the windows, to a sufficient temperature. For this reason, the U-value of the glass should be high enough (according to the local climate) and the radiators should be placed under the window.

Developments on thermal comfort theory (e.g. adaptive thermal comfort)

The standard EN ISO 7730 was originally developed through laboratory tests of perceived thermal comfort with the limited intent to establish optimum levels for fully climate-controlled buildings and has in the absence of any credible alternative been applied universally across all building types, climates and populations. Findings from field measurements in other building types and/or buildings with natural or hybrid ventilation show that thermal preferences can vary widely from predictions based on ISO 7730. This had led to the development of an alternative thermal comfort standard [de Dear et al 1998] that is able to account for contextual and perceptual factors absent in a laboratory setting. These include:

- Physiological adaptation (known as acclimatization, changes in biological responses)

- Behavioral adaptation (conscious or unconscious actions by the person to alter their thermal balance)
- Psychological adaptation (alteration of perception of and reaction to physical conditions due to past experience and expectations)

The result show that occupants in natural or hybrid ventilated buildings appear tolerant of – and in fact prefer – a wider range of temperatures that more closely reflect the local patterns of outdoor climate change. This is the basis for use of figure 1 and the Reshyvent recommended targets in stead of ISO 7730 targets.

2a.3 Noise

- What do building regulations say?
- What noise-related problems can arise in ventilation system, and how to mitigate them
- What equipment certification schemes exist?
- noise in urban environment. Increasing traffic noise and its impact on choice of system

The acceptance and appreciation of ventilation systems is mainly determined by the perceived indoor air quality, thermal comfort and noise. Noise in relation to ventilation systems can be divided into three categories:

- outdoor noise (entering the dwelling through ventilation openings, cracks, mechanical supply and exhaust openings etc.);
- noise generated by components of the ventilation system;
- sound transported within or between dwellings by the ventilation system.

For the consideration of noise, the following ventilation principles are discriminated:

- natural air supply and natural air exhaust;
- natural air supply and mechanical air exhaust (including local and/or central systems,
- mechanical air supply and mechanical air exhaust
- hybrid systems with natural supply and fan assisted exhaust;
- hybrid systems with fan assisted supply in facade and fan assisted exhaust;
- hybrid systems with fan assisted supply b ducts and fan assisted exhaust;
- The hybrid systems are classified conform (de Gids) ??

Depending on the type of ventilation system and the strategy, one or more of the three areas indicated in table below are important.

Table 3 Noise aspects in relation to ventilation systems

	Nat. vent.	Natural supply/mechanical exhaust	Mechanical supply/mechanical exhaust	Hybrid Nat.supply in facade; Fan assisted exhaust	Hybrid Fan assisted supply in facade; Fan assisted exhaust	Hybrid Fan assisted supply by ducts; Fan assisted exhaust
Hybrid ventilation class (W. de Gids)	-	-	-	0-5,11,17,18	8,9,13,-16	6,7,10
Outdoor noise	X	X	0	X	X	0
System noise	-	0/X	X	0/X	X	X
Sound transmission	0	0	X	0	0	X

- irrelevant/not applicable
- o slightly sensitive
- x sensitive

2a.3a Outdoor noise

In noise loaded areas the selection and the applicability of different types of ventilation systems is determined by the noise level on the facades. In general the noise reduction of a facade, including a purpose provided ventilation opening, is approximately 20 dB(A). In most countries the allowable sound level in a room, due to outdoor noise sources as traffic and

industrial plants, is 35 dB(A). If outdoor noise levels on a facade exceeds 55 dB(A), ventilation systems with openings in a facade will need acoustic provisions. More over additional acoustic provisions are necessary for other parts in the facade (glazing, weather stripping, panels etc.)

Noise in the urban environment

Noise is one urban form of pollution affecting seriously the quality of life of the inhabitants. The most important source of noise pollution is the road traffic, the aircrafts and railways as well as the building and development cites. The work places for many of the city inhabitants can also be of importance in respect to the noise problem.

Many communities have proposed noise level standards for motor vehicles as part of the norm-setting process of the market. Naturally these standards have been modified to cope with the new technological achievements.

Many studies on the effects of noise on human health suggests that the outdoor level of noise should not exceed a daytime equivalent sound pressure level, (despl), of 65 db, the level at which serious impacts of noise are noticeable. In fact areas where the noise level exceeds the level of 75 dbs, are considered dangerous since the noise can cause hearing loss.

According to the EEA recent records, 113 million people in Europe, (17% of the population), are exposed to despl over 65 db and 450 million people (65% of the population) to above despl 24h 55 db. About 9.7 million people are exposed to unacceptable noise levels above despl 24h 75 db. In large cities, the percentage of people exposed to unacceptable levels is two to three times higher than the national average.

The existing data in Europe do not allow to plot trends in noise exposure for many major European cities. However exceedances of the maximum acceptable level of 65 db occur in most cities (Figure 5).

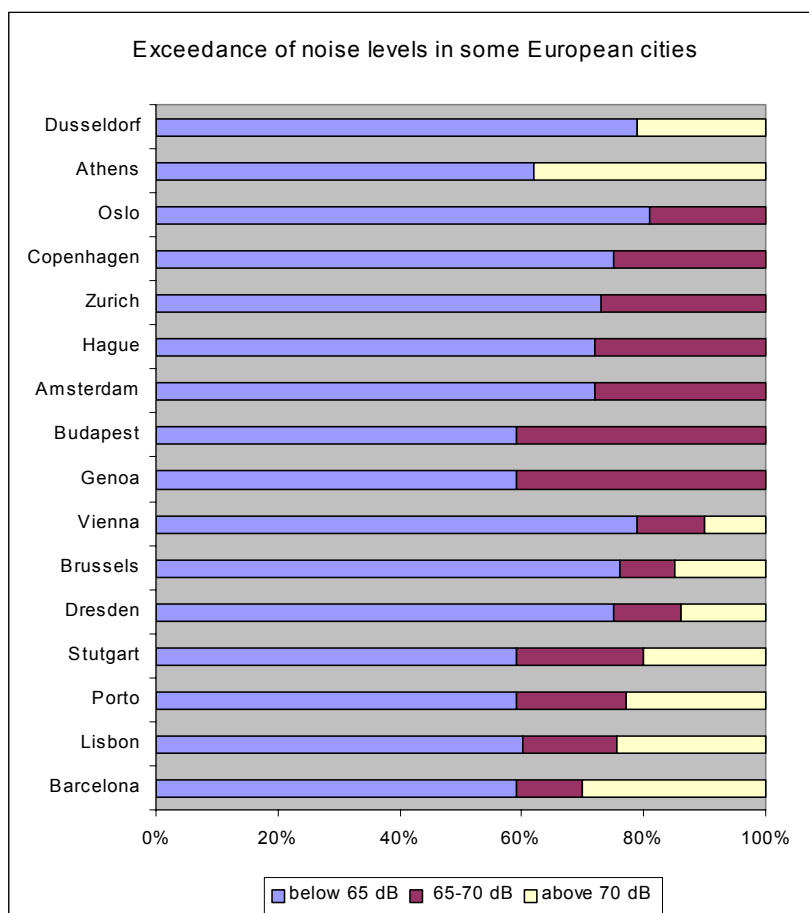

Figure 5 Exceedance of noise levels in some European cities

The impact of urban noise on the choice of ventilation system

Noise levels are one of the most important factors that contribute to satisfaction with a ventilation system. For the case of natural ventilation, one is usually concerned with the indirect noise originating either outside the building (traffic noise, noise from industrial plants and restaurants, airports) or inside it. For mechanical ventilation systems, the noise is mainly connected to the fans and the mounting materials of ducts (structure born), as well as, the control valves and airducts (aerodynamic noise).

On that basis, noise can be divided into the following three categories:

- Outdoor noise entering the dwelling through the ventilation openings (windows, cracks, slots), most important for natural ventilation and less important for mechanical ventilation.
- System noise generated by the mechanical ventilation system.
- Sound transmission within or between dwellings, either by the ventilation system and/or the internal ventilation provisions (very important for systems with both mechanical supply and exhaust, but relevant for natural and exhaust-only ventilation systems too).

The impact of outdoor noise on the ventilation system is mainly discussed in the following paragraphs.

Dwellings with unweatherstripped windows and regular glazing (single pane or regular double-pane) achieve a noise reduction of approximately 20dB(A), whereas when the window is open only 15dB are achieved. If the noise level outside the window exceeds 50 to 55dB(A), natural supply systems require acoustic measures.

The noise reduction of a building facade is determined by the overall sound reduction system of the façade plus a contribution due to the acoustic properties of the room itself (absorption):

$$GA = RA + 10 \cdot \log\left(\frac{A}{S}\right) - 3 \quad (1)$$

Where RA is the overall sound reduction index of the façade, A is the room absorption in m² and S is the total surface of the façade.

Noise transfer through building facades can be through the closed parts (bricks, panels), through the glass, through ventilation openings and

through joints and cracks. If noise reduction beyond the known level of 20 dBA is required, one should seal joints and cracks (resulting in reduced passive ventilation), as well as, sound-proofing of the facade elements. Special sound-proofed ventilation openings may be required too. Weatherstripping windows result in noise reduction, as well as using acoustic glass (thicker glass and gas-filling in double-paned glass) – the latter measure being less effective and more expensive.

Noise reduction in rooms with exhaust ducts for natural ventilation (stacks or shunt ducts) may be influenced by noise sources at the roof level (aircraft or elevated roads). For rooms without special façade soundproofing, this effect is minor, but it may become important when a high noise reduction value (30 dB(A) to 35 dB(A)).

2a.3b System noise

Controlling noise levels caused by ventilation systems is in practice one of the most important factors to contribute to the satisfaction with a ventilation system. Air duct systems in dwellings transport noise generated by fans and aerodynamic noise generated by bends, control valves, grilles etc. In general silencers will be necessary (length > 1 meter) in ducts leading to habitable rooms.

2a.3c Impact on noise reduction of partitions

The composite sound reduction is the result of different sound channels from one room to the other. One of this sound channels may be the ventilation system (cross-talk). Cross-talk can be brought about through the air duct system, overflow grilles and ventilation openings in partitions, duct transitions etc.

2a.3d Recommended noise targets:

Requirements: Building regulations / RESHYVENT recommended targets

[WP5-WR-2]

Sound level in rooms are an important element of any indoor environment evaluation.

The acoustic indoor environment is a result of sound emitting sources, of sound transport and respective attenuation measures, and of outdoor conditions (outdoor noise level).

Target values are to be set according to the relation between the acoustic quality of the ventilation system and the acoustic quality of the building, i.e. poor acoustic quality of ventilation systems in dwellings with high acoustic quality of partitions are to be avoided.

Table 4 Existing criteria, thresholds, target values of the sound pressure level (SPL) in the room:

		night time	daytime
Swiss standard SIA 181:	Minimum requirements	30 dB(A)	35 dB(A)
	Higher requirements	25 dB(A)	30 dB(A)
CR 1752 (values for hotel rooms, no values are given for residential buildings)	Category A	25 dB(A)	30dB(A)
	Category B	30 dB(A)	35 dB(A)
	Category C	35 dB(A)	40 dB(A)

In RESHYVENT the recommended target value of the SPL is 25 dB(A) in sleeping rooms.

2a.4 Design process - integrated design approach, with examples

General concepts and experiences

- Building-integrated ventilation concepts
 - What exactly is hybrid ventilation, what it isn't?
... it is just one element of building-integrated design, split up into individual features
 - Overall experiences so far from hybvent buildings
- Passivhaus principles

The choices in the design process influence strongly the energy use by the system.

Depending on the flexibility to fit a ventilation system to any type of floor plan of a dwelling leads often to systems which have a non optimal duct layout. An integral approach is needed. In practical terms these choices in the design process may easily lead to a energy use for fans which is four times more than necessary. As an example the following result produced by the TipVent tool for evaluating fan energy is given below:

Table 5 Example of how different design choices can affect fan power

	ducting adapted to building lay out	normal or standard duct ducting design	optimal ducting integral approach
fan power at a flow rate of 42 dm ³ /s	40 W	21 W	7W

Specific examples of integrated solutions (specific technical solutions)

- Alusta
- TIPVENT
- NBI - RESHYVENT prototype
- Prototype from Sendai, Japan
- Case studies from HybVent (just reference)

TIPVENT integrated design approach

More information may be found in TipVent final report [2]

??

Figure 6 Parallel ducting to kitchen, bathroom and toilet [TNO]

Alusta integrated design approach

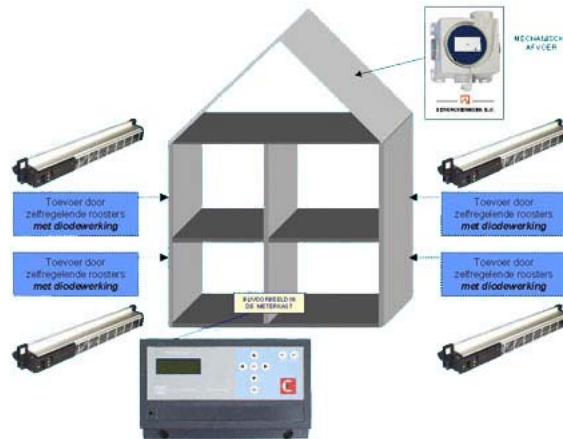

Figure 7 Integrated mechanical exhaust system with self-regulating fresh air inlets [Alusta]

Building integration of self-regulating fresh air inlets

The whole range of inlets is deliverable with manual adjust possibilities and they are also deliverable as selfregulating inlets. Selfregulating according to the Dutch standard means that the inlet keeps a constant flow from 1 Pascal upwards.

Inlets are deliverable with various specifications regarding capacity and noise-reduction. There is also a great variety in possible ways to integrate them into a facade. The general accepted way to integrate inlets is to place them on top of the glass in a window (Figure 8a) or placed in a wooden, plastic or aluminium frame above the glass (Figure 8b). In any of these cases there is a preference to install the inlet directly above a heat-source to make maximum use of the thermal effect of rising warm air. On initiative of architects it becomes lately more and more common to place inlets so that you keep them out of site from outside (Figure 8c).

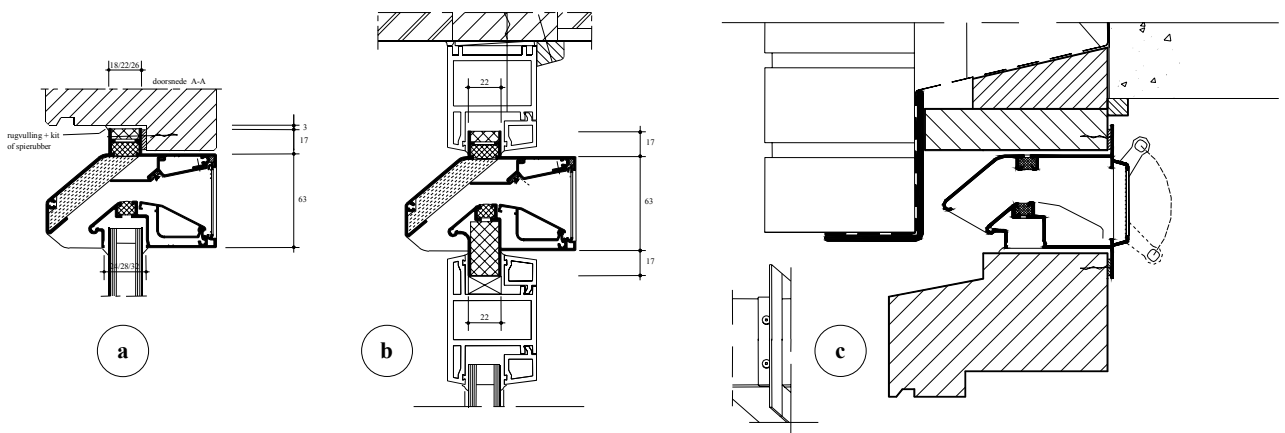

Figure 8 Three examples of installation of fresh air inlets [Alusta]

On the inside of dwellings there are normally no further measures integrated to influence the flow direction into the room. In office buildings however it is common to integrate solutions witch prevent the incoming air from falling down directly (example Figure 9).

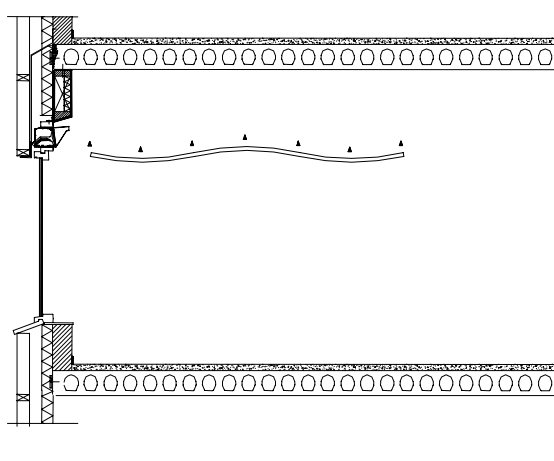

Figure 9 Office space with ceiling plenum to reduce downdraught from fresh air inlet

To prevent comfort problems in dwellings such as draft there is advised in the Netherlands to install the inlet at a minimum height of 1,8m above the floor. In addition to that there are demands for adjusting possibilities for the occupant so that the flow can always be adjusted at the right level.

Case studies from Hybvent project

In the frame of the HybVent project, 15 buildings were selected as case studies (7 office buildings and 8 schools). A lot of knowledge has been acquired in the design process and during the first year(s) of exploitation, thanks to intensive monitoring. The lessons learned are probably not valid for offices and schools only, but hopefully could be extended to dwellings.

The table presents the techniques used in 13 case studies. For instance, night ventilation was largely exploited as a passive cooling strategy.

The case studies have shown that hybrid ventilation has to be thought since the earliest stage of the project, as it has an important impact on the building design. For instance, 7 buildings used chimneys or turrets, 3 used undergrounds ducts or culverts.

HV probably requires more sensors than NV or MV. This could be more a problem for dwellings than for offices, as the price of some sensors (e.g. CO₂) is still expensive and as they could require maintenance, which is hard to implement in dwellings (at least in some countries).

HV requires to implement control strategies that are more complex than for MV (or NB). However, experience has shown that control strategies should be robust. Too much complexity has damaged the performances of some HVS.

The commissioning process of the HVS has needed considerable care; hopefully, this due to the youth of the technology and will be solved by product/system standardization.

The first year(s) of running have enlightened that individual control is essential for user acceptance; this is not only valid for HVS but also for many building service techniques.

Some lessons learned in offices and schools are difficult to extrapolate to dwellings. For instance, "energy performance evaluations have generally shown a reduction in overall energy consumption of about 20-30%, and of about 50% in electricity for ventilation".

More information about HybVent can be found on: <http://hybvent.civil.auc.dk/>.

The brochure "Principles of Hybrid ventilation" summarises the work and the findings of the project, and contains an overview of the characteristics and lessons learned from the case studies. The brochure can be found under:

<http://hybvent.civil.auc.dk/> > Publications > Principles of Hybrid ventilation

Detailed reports on 13 case study buildings can be found under:

<http://hybvent.civil.auc.dk/> > Pilot Study buildings

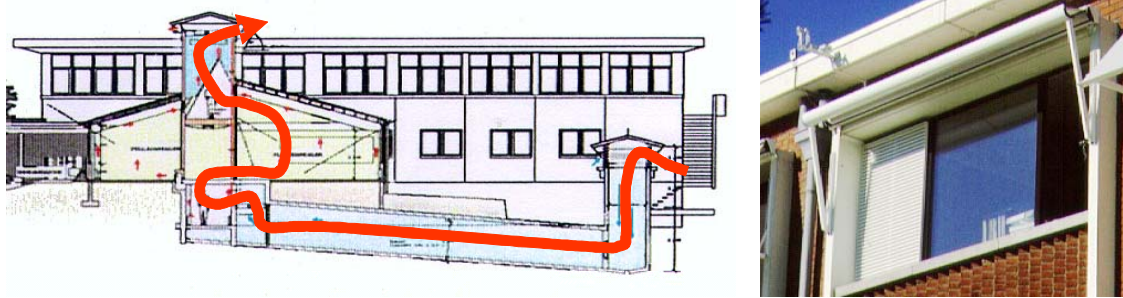

Figure 10 Examples of building-integrated ventilation solutions
Left: Grong School, Norway: Ground-coupled fresh air ducts, and exhaust stack
Right: Probe building, Belgium: Louvres for night ventilation

Table 6 Ventilation concepts applied in thirteen Annex 35 case studies From "Principles of Hybrid Ventilation" (Heiselberg P. et al., 2002)

Building name - Country - Office/School	Ventilation concept										
	Stack effect	Wind driven	Displacement ventilation	Mixing ventilation	Cross flow ventilation	Natural night ventilation	Mech. night ventilation	Natural cooling	Air conditioning	IAQ control by natural means	IAQ control by mech. means
Wilkinson - Au - O		●			●				●	●	
IVEG - B - O	●	●		●	●	●		●			●
PROBE - B - O	●	●		●	●	●		●			●
B&O HQ - DK - O	●	●	●		●	●	●	●		●	●
Brecht Gym. - D - S	●					●		●		●	
I Guzzinin - I - O	●				●	●		●	●	●	
Liberty tower - J - S	●	●			●	●	●	●	●	●	
Tokyo Gas - J - O	●	●			●	●	●	●	●	●	●
Fujita - J - O	●	●			●	●		●	●	●	●
Mediå - NW - S	●	●	●		●	●	●	●		●	●
Jaer - NW - S	●		●			●	●	●		●	●
Tānga -SW - S	●	○		●		○	○	●		●	●
Waterland - NL - S	●	●		●		●	●	●		●	●

Renson Healthy Building concept

Renson built its new offices in accordance with the "Healthy Building Concept" The Healthy Building Concept offers good air quality through natural ventilation as well as a pleasant temperature during summer through controlling solar gain by means of sustainable exterior solar shading and of applying intensive natural ventilation at night. This concept can be applied to new builds as well as refurbishment.

Basic ventilation is permanently guaranteed through supply of fresh air via flap ventilators. Therefore both an acoustic ventilator was placed above the windows that supply the air for the overnight ventilation (just underneath the false floor), as well as a ventilator that was glazed in the windows of the meeting rooms facing the production plant. Air extract is done naturally through chimneys. If not sufficient, fans integrated in the chimneys allow to increase the ventilation capacity, which was designed at an airflow rate of 25 m³/h/person. Due to the great ceiling height of 3.6 m, a large internal volume was created which acts as a good buffer for air pollutants and internal heat fluctuations.

Night cooling is applied in summer months in order to intensively cool down both the internal air and the thermal mass (20 cm concrete floor and 25 cm concrete roof) in the building. During daytime the cooled thermal mass is used to cool the internal air and to reduce the ceiling's radiant heat. Via passive stack ventilation, air supplied via windows at all sides of the building (most of them computer controlled), is extracted through 15 stacks also provided with automatic opening and closing windows (Figure 11). Under windless climate conditions and supposing a temperature difference of 5°C between inside and outside, still an air exchange of three volumes per hour is realised. Since the building has a very open structure with little walls and doors, cross-flow ventilation can considerably enhance this minimum airflow exchange. At the outside, the openable windows are covered with horizontal blades or louvres equipped with an insect mesh in order to ensure weather and insect tightness.

To successfully apply night cooling, both internal and solar heat gains should be avoided as much as possible. Therefore, through durable and adjustable external solar shading on the South West façade an excess heat gain in the building is avoided. Heat transfer through the building envelope is limited by the highly insulated flat roof, floor and curtain walling having a U-value of 0.3, 0.5, and 1.3 W/(m²·K), respectively. Since a floor area of about 15 m² is provided per person, the internal heat gains are limited.

Daylight can maximally enter the building via the curtain walling all around the building (wall surface constitutes 35% of the total floor area) and chimney windows.

It can be concluded that the new offices are a good example of harnessing nature to a maximum effect in an aesthetical and functional building in order to create a comfortable work environment with minimal energy consumption.

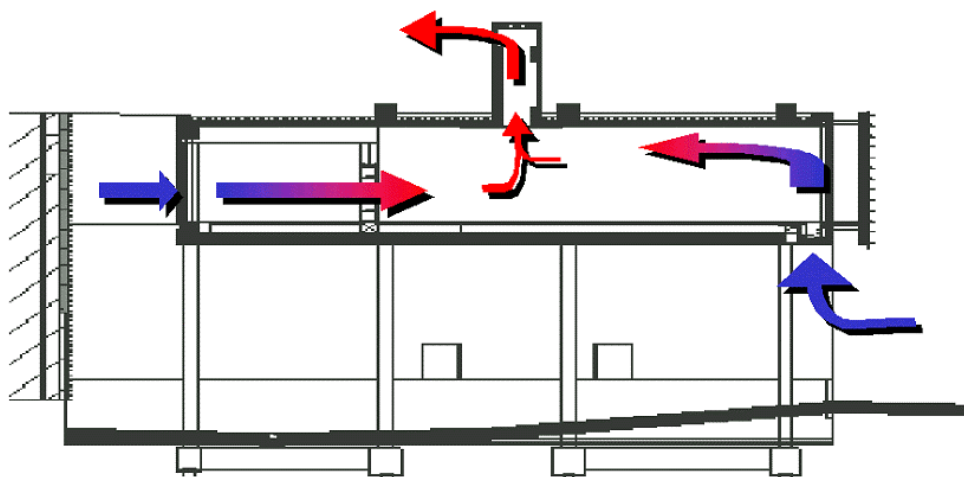

Figure 11 Air flow pattern via passive stack ventilation during night cooling [RENSON]

Hybrid ventilation in French residential buildings

<http://vti-france.com>

<http://www.astato.com>

Although the mechanical exhaust systems are now the most commonly used systems, the passive stack ventilation systems called in French 'ventilation naturelle' (different from natural ventilation by opening windows called in French 'aération'), were common in use in the buildings built in the sixties. When renovating existing building, air leakage of the envelope is often reduced ; this can lead to an insufficient ventilation rate. In France since the eighties, has been developed a hybrid ventilation system using fan assisted cowls.

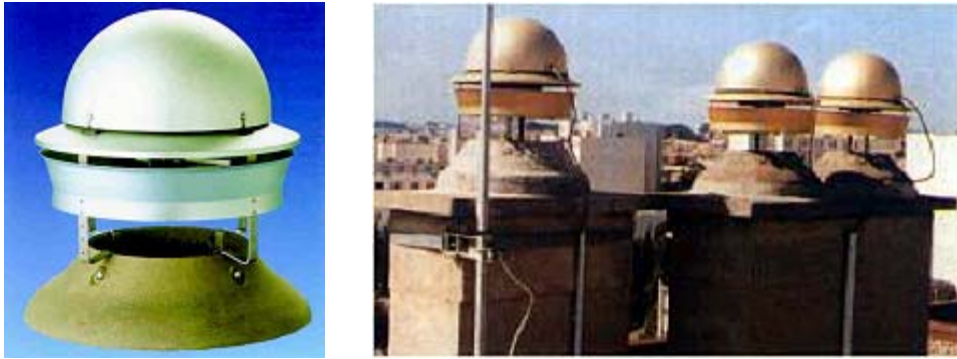

Figure 12 French fan-assisted cowl, and example of installation

These cowls have a two-speed motor:

- the first speed gives ventilation flow when natural driving forces are insufficient ; it is generally controlled by a thermostat on outdoor temperature,
- the second speed (optional) gives an extra flow when cooking ; it is generally controlled by a clock (11h to 13h and 18h to 20h).

The cost of these systems (including implementing in the building) is about 700 to 800 €

2b Operational qualities of ventilation systems

2b.1 Operation & maintenance

2b.1a General

- Complexity lack of experience or time among installation contractors. the problem is need for low cost

Controlling the quality is one of the most important aspects in relation to the function and the final appreciation of ventilation systems. This is of special concern regarding advanced ventilation systems like hybrid ventilation. There is a strong relation between the realised quality, (i.e. according the specifications and terms of reference), and energy use as well as indoor environment (IAQ, thermal comfort, noise). A ventilation system has to perform according to the intended design and specification. Not only on the moment of the hand-over of the system, but also during the operation, i.e. during its lifetime. This is expressed as the reliability of a ventilation system. Reliability means:

- assuring the desired air flow under different (climatic) circumstances;
- assuring the desired air flow during the lifetime.

Commissioning is an instrument to assure a certain level of quality and reliability. According to ASHRAE guideline 1-1996 commissioning is the process of ensuring that systems are designed, functionally tested, and capable of being operated and maintained to perform in conformity with the design intend. Therefor commissioning has to be embedded in a total structure for quality control of the process, from programme phase up to and including the operation phase.

2b.1b Procedures and tools for Commissioning and Quality Assurance

- What commissioning practices are typically used in different countries ? (Peter Op't Veld)
- What features should systems have to facilitate good Cx ? (during hand-over and the operation phase, i.e. specifications of control, measurement and adjustment devises)
- Too much complexity is bad - lack of experience or time among installation contractors
- control inspections throughout life (e.g. Sweden) – relevant for blocks of flats?

This paragraph gives an overview and a summary of Commissioning and QA procedures and tools in:

- The Netherlands
- Sweden

- Norway
- Finland
- France
- Switzerland
- UK
- USA
- Canada

Netherlands

Procedures

In the general there is a certified building inspection by a National Assessment Guideline "BRL 5006".

Complying with a "BRL" means automatically complying with all relevant Building Regulations. For building services there are some separate BRL's on heating (BRL 6001) and ventilation (BRL 6002). There are technical references (so called ISSO – publications) in which all technical guidelines as well as quality levels are elaborated. The Model Quality Control Climate Installations (MQC) structure is used in these publications. MQC is an instrument leading to *process* certification, i.e. using a BRL and its technical references gives certainty about the process. Depending on the ration of risk and costs (depending on complexity of projects) there can also be a "one-on-one" inspection, i.e. commissioning. Commissioning in the Netherlands is related to *projects* with a commissioning authority. If this commissioning authority is "certified" then the commissioning process fits in BRL 5006.

Tools

The ISSO publications (Netherlands Institute for Building Services) in "MQC-style" are the technical reference for quality assurance and commissioning:

- ISSO 50 - hydronic heating;
- ISSO 61 - ventilation (general);
- ISSO 62 - ventilation (specific balanced ventilation);
- ISSO 56 - hydronic control;
- ISSO 49 - floor and wall heating;
- ISSO 58 - warm air heating.

There are also simple checklists for LT-heating in new and existing buildings (referring to ISSO publications). For existing buildings there is the Energy Performance Assessment (EPA), in fact an energy Re-commissioning of existing buildings.

Sweden

Procedures

Commissioning and quality assurance is partly voluntary and partly based on legislation (electrical safety, ventilation). In general, for building services the AMA procedures are used with general specifications for materials and work in HVAC installations. These are voluntary but commonly used.

For ventilation there are the OVK procedures including a compulsory checking of performances of ventilation systems. This system is unique in the world. A 1st evaluation of results in 1997 showed an improvement of quality. There is also Quality Assurance, marked and based on the P-mark of SP. The success is depending on market and economical situation of building market.

Norway

Procedures

Norway has very strict building regulations including obligatory control and checks for design and construction process. Constructors and consultants need permission and must be certified for certain subjects (fire safety...). There is an internal quality control within (building) companies including end-control (forms, calculations) by authorities and a 3rd year inspection of building. In practice there are problems: system is bureaucratic, especially for SME's.

Finland

Building regulations

Ventilation includes:

- Inspection procedures, functional tests;
- Control before acceptance:
 - measuring / adjusting flow rates;
 - tightness ducts;
 - recording of Commissioning measuring & tests;

Heating includes flow balancing of hydronic circuits

HPAC register

The HPAC register contains information for building professionals for different target groups with different scopes. There are several actions to be taken in different stages of the project.

Overview of Commissioning methods

	Program	Planning	Preliminary design	Working design	Construction	Acceptance	Post acceptance
General							
Organisation							
Communication							
Requirements		<ul style="list-style-type: none"> *Environmental impact assessment (RAP 95) *Building permit (RAP 95) *Enquiry of the energy, water and electricity consumption (TATE 95) *Plan for action (RAP 95) *Energy economics (D3) 	<ul style="list-style-type: none"> *Audited design standards (ARK 95) *Clarification of premises and leading principles of architectural, operational and technical solutions (ARK 95) 	<ul style="list-style-type: none"> *Preliminary allocation scheme (ARK 95) *Preliminary maintenance plan (ARK 95) 	<ul style="list-style-type: none"> *Check lists (TATE 95) *Pressure test (D1) *Ventilating systems (D2) *Heating systems (D3) 	<ul style="list-style-type: none"> *Check lists (TATE 95) *Final allocation scheme (ARK 95) *Final maintenance plan (ARK 95) 	<ul style="list-style-type: none"> *Energy audit
Means	<ul style="list-style-type: none"> *Needs identification report (ARK 95) 	<ul style="list-style-type: none"> *Target values for indoor climate in the categories S1, S2 and S3 from the "Classification of indoor climate 2000" *Acceptance of needs identification report (ARK 95) 	<ul style="list-style-type: none"> *Consumption report for energy, water and electricity (TATE 95) 	<ul style="list-style-type: none"> *Implementation plan (TATE 95) 	<ul style="list-style-type: none"> *O&M plan (TATE 95) *Airtightness of the ventilating ducts (SFS 52542) *Function of the air conditioning systems (SFS 5768, SFS 5769) 	<ul style="list-style-type: none"> *Minutes of an inspection (RAP 95) *Report of the functionality of the systems (TATE 95) *Testing measures (RAP 95) 	<ul style="list-style-type: none"> *Operational journal (RAP 95)
Purchase Time		<ul style="list-style-type: none"> *Planning schedule (RAP 95) 	<ul style="list-style-type: none"> *Contractor (RAP 95) *Planning timeschedule (ARK 95) 		<ul style="list-style-type: none"> *Project schedule (RAP 95) 		
Finances		<ul style="list-style-type: none"> *Financing plan (RAP 95) *Cost comparison for the energy consumption (TATE 95) *Maintenance cost estimation (ARK 95) 	<ul style="list-style-type: none"> *Maintenance cost calculation (RAP 95) *Investment calculation (TATE 95) 		<ul style="list-style-type: none"> *Financing schedule (RAP 95) 	<ul style="list-style-type: none"> *Report of the financial account (RAP 95) 	
Realisation							
Experience							

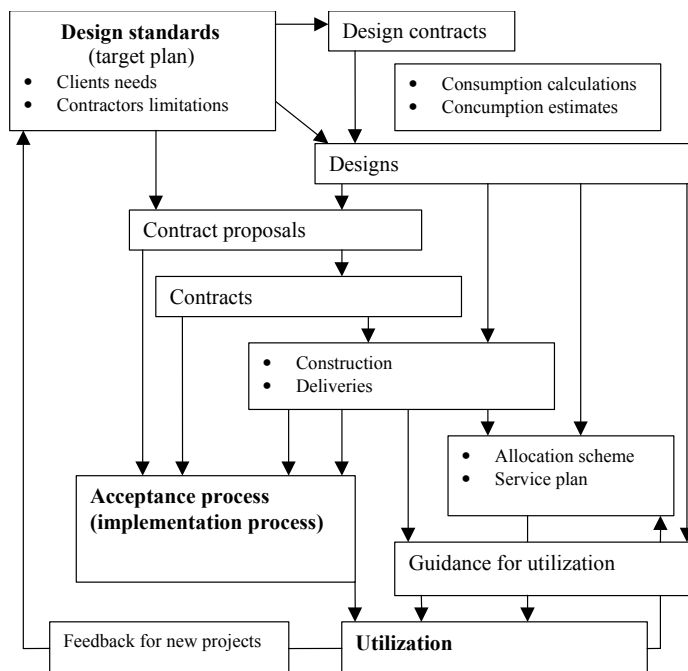

Figure 13 Finland - Commissioning building project phases

Switzerland

In Switzerland the term Commissioning is not known or common. However, commissioning is becoming daily practice because of:

- awareness of energy-efficiency and energy standards & regulations;
- increasing influence of Commissioning professionals.

Commissioning is during acceptance / hand-over phase under responsibility of HVAC designer / installer.

Commissioning during operation phase (monitoring and optimisation): linking with CO2 tax in future (proving increasing energy efficiency with 10%).

UK

Procedures

Commissioning in the UK is more common, but there is also an other definition. In UK commissioning is restricted to acceptance phase. Commissioning will be mandatory in new building regulations of England and Wales. There are CIBSE publications on Commissioning as references for control (Building Regulations Part L: Amendments: regs. 2 & 3 "Definitions of controlled work"; Reg 18 "Carry out tests of Compliances...").

Tools

Documents and publications on Commissioning by CIBSE:

- CCA Air Distribution Systems (only *what* has to be done, not *how*);
- CCB Boiler Plant (see CCA, but will be revised);
- CCC Automatic Controls (most recent, integral approach for specials, Commissioning management, checks during operation phase);
- CCR Refrigeration Systems;
- CCW Water Distribution Systems (also design procedures);
- CCS Set of 5 Commissioning Codes;
- CCL Light.

USA

Procedures

Commissioning is common as term but not implemented as "daily practice" (only in ~ 5% of new buildings; 0,03% in existing buildings). Only a limited number of states have commissioning items in building regulations.

Implementation of commissioning, tools and procedures are more elaborated in the NW states.

Tools

- ASHRAE publication Commissioning
- PECI: Model Commissioning Plan and Guide Specifications:
 - Part I: Commissioning requirements - Design phase;
 - Part II: Model Commissioning Plan - Design phase;
 - Part III: Commissioning guide specifications;
 - Part IV Model Commissioning Plan - Construction phase;
 - Pre functional Checklist Forms" (20 spec. sheets);
 - "Sample Functional Test Forms" (28 spec. sheets).

Canada

Procedures

Commissioning is not imposed by legislation. There is an indirect role in building registrations in relation to health and safety. There are two leading organisation in field of Commissioning:

- BC Building Corporation
- Public Works & Government Services Canada.

The project management has the responsibility of commissioning, assisted by a Commissioning manager.

The costs for Commissioning are estimated on 1 - 4 % of project costs, depending on risk in relation to tolerances / discrepancies with specifications.

Specific procedures

BC Building Corporation:

Commissioning is required by Building Technical Standards. Commissioning is mainly focused on acceptance and operation.

Public Works & Government Services Canada:

Commissioning is an essential part of integral design process including a:

- Functional component: all aspects for program of requirements
- Operational component: operation and maintenance, including necessary facilities.

Commissioning is used for Quality Management. Commissioning is also used as a transfer between implementation and operation.

2b.1c Model Quality Control and Commissioning for ventilation systems

A structure for overall quality control for building services, and advanced ventilation systems in particular, is the Model Quality Control Climate Installations (MQC). Its intention is to control the total production process including specifications, design, construction, hand-over and operation. It focuses on avoiding failures on all strategic aspects and moments in this process.

It is an instrument for controlling the total process of making building services and can be applied for advanced ventilation systems and concepts (i.e. ventilation systems in relation to properties of the building and other building services). It contains all operational techniques and activities, necessary to realise a defined level of quality. The quality level has to be precisely formulated. In this framework "Quality" means that the delivered performance matches the required and precisely formulated requirements and expectations of the principal, including time planning, budgets as all technical aspects.

MQC is focussed on:

- avoiding failings in all the phases of the process, starting with the programme phase up to and including the operational phase;
- assuring reliability in defined time intervals

In order to deliver a good final product the activities of all individual building partners must be geared to one another. In all the phases of the process several activities will be carried out that have an impact on the quality of the final product. For example, a principal is perhaps not able to formulate his requirements and expectations in the program phase. This leads to the risk that technical ideas are developed in the design phase and elaborated in the elaboration phase that will not be financial feasible. Another risk is the development of technical ideas in the design phase that has a certain level of technical complexity. If the required skills of installers are not well defined there is a major risk of failures during the execution and the operation of the installation.

Model Quality Control is a general model that can be applied for all kinds of processes (building and building services, industrial etc.). Regarding HVAC systems it is possible to elaborate a MQC system for the total ventilation system or for separate elements (i.e.: heating, cooling, ventilation). In the Netherlands the MQC structure is elaborated for heating systems and domestic ventilation systems.

The most important characteristic for MQC for ventilation systems however is a structure that follows all the process phases. This enables to build in a number of strategic decision moments in the (building) process and to assess if a ventilation system meets the targets and requirements, as defined in the program phase. As the total quality is determined by several aspects (not only technical but also financial, organisation and communication) 10 different quality control aspects are discriminated.

This leads to a so-called quality matrix. On the horizontal axis of the matrix the phases of the process are distinguished. On the vertical axis of the matrix ten distinguished quality control aspects are listed.

Table 7

		project phase				
		I programme	II design	III elaboration	IV realisation	V operation
quality control aspect	0 general					
	1 organisation					
	2 communication					
	3 requirements					
	4 means					
	5 purchase					
	6 time					
	7 finances					
	8 documentation					
	9 experience					

Process phases:

I Programme phase: In the programme phase an inventory takes place of requirements, demands and expectations of the ventilation system. Also all limiting boundary conditions must be listed and formulated. For the preliminary selection of the concept and type of ventilation system the main consequences are visualised. At the end of the programme phase the principal, architect and (ventilation) consultant have enough information to make a first selection of the ventilation concept/system.

II Design phase: In the design phase the ventilation concept, as preliminary selected in the programme phase, is elaborated by the ventilation consultant. Communication with architect and constructor takes place to tune building technical and architectural boundary conditions with the ventilation concept and vice versa. There will feedback to the starting points of the programme phase. At the end of the design phase a final selection of the ventilation concept takes place.

III Elaboration phase: In the elaboration phase the ventilation concept will be elaborated to a system level and a component level. Specifications will be elaborated and materialisation takes place in this phase. This includes also detailed financial calculations.

IV Realisation phase: In the realisation phase the actual construction of the ventilation system takes place. This phase ends with the acceptance and hand-over of the installation. Note that during this phase, and in particularly during the acceptance, "commissioning" takes place according to the "English" definition (i.e.: testing of the installation of realisation to check if it meets the terms of reference).

V Operation phase: In this phase the actual operation of the building and ventilation system takes place after the acceptance and hand-over of the installation. In ASHRAE publication 1996-1 this phase is cold "post-acceptance phase". In this phase commissioning is the continued adjustment optimisation and modification of the ventilation system, including maintenance to meet and to maintain the specified requirements.

Quality Control Aspects:

0 General: Description of the general objective(s) of each phase including the starting points, boundary conditions and points of particular interest.

1 Organisation: Description and allocation of tasks and responsibilities.

2 Communication: Description and recording of the necessary information exchange between all parties involved in the process is reported including a description about the necessary consultations including which parties, when, the objective and deliverables of each consultation.

3 Requirements: Inventory of internal and external requirements including a base level of legal requirements like buildings regulations, standards and others as well as recommendations, according to (higher) quality level.

4 Means: Listing of all necessary calculation methods, execution protocols, assessment and evaluation tools including references to standards (like calculation, determination and measurement methods) measurement instruments and literature.

5 Purchase: Description of necessary external expertise that has to be purchased.

6 Time: Guarding of the object planning as well as process planning.

7 Finances: Controlling and guarding of the object costs (i.e. ventilation installation) as well as the process costs (co-ordination, consulting, commissioning).

8 Documentation: Reporting of the input and output of all sequencing phases.

9 Experience: Evaluation of the process at the end of the phases

From the main cells in the matrix the will be references to other cells. In these cells is stated which subjects and partial subjects are addressed. In separate specification sheets these (partial) subjects are further elaborated:

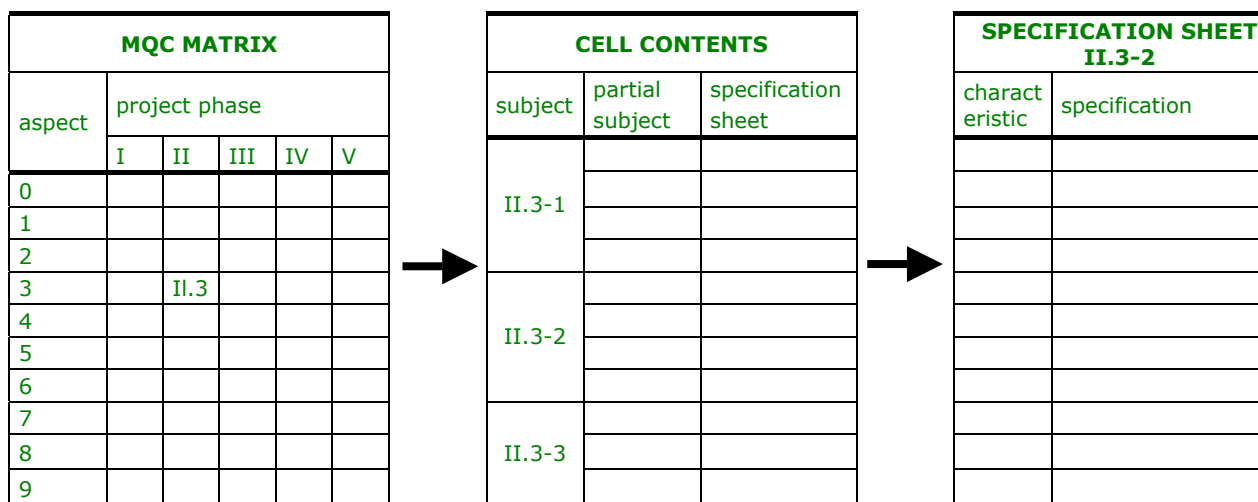

Using MQC or making a document conform the MQC structure it is not necessary (and often not possible) to fill in all cells. But every information that is available can be "recorded and stored" in logical way in a cell, elaborated in specification sheets. Often this information is spread over two or more phases, consequently, over several specification sheets, corresponding with the distinguished phases and/or quality control aspects. It is important to analyse exactly in which phase and for what quality control aspect the information is necessary. Therefore it is important to know the meaning of each different quality control aspect. It is not possible and necessary to address all the quality control aspects. The chapters 5, and specially 6, 7 and 9 are much more related to specific projects. On the other hand it is possible to write general guidelines for quality control of ventilation systems within this MQC structure without addressing these aspects.

MQC is not only for consultants and installers. All partners in the building process have to deal with the MQC and will have to confirm to it. Also the principle must be aware of the fact that his responsibility reaches further then only the financial aspects. He has an important role during the program phase to formulate functional specifications, that can be "translated" by his consultants in a technical design and specifications.

The MQC structure provides a perfect basis for the implementation of commissioning within a (production) process. Within the matrix cells can be identified which should be addressed for commissioning. Specification sheets can be further elaborated. As a commissioning document on (hybrid) ventilation has a general character (i.e. not related to a particular project) not all cells can be filled in. More over all descriptions and specification sheets will give in many cases guidance how to fill in specifications related to a "real" project (this will be the case for organisation, communication, purchase, time, finance and experience). On the other hand, aspects as requirements, means and realisation can be elaborated in detail.

In general, following MQC cells can be filled regarding commissioning:

Table 8

		project phase				
		I programme	II design	III elaboration	IV realisation	V operation
quality control aspect	0 general	I.0	II.0	II.0	IV.0	V.0
	1 organisation	I.1			IV.1	V.1
	2 communication	I.2			IV.2	
	3 requirements	I.3	II.3	III.3	IV.3	
	4 means	I.4	II.4	III.4	IV.4	V.5
	5 purchase				IV.5	
	6 time				IV.6	V.6
	7 finances			III.7	IV.7	V.7
	8 documentation				IV.8	V.8
	9 experience				IV.9	

I Program phase:

In 0 commissioning must be mentioned as one of the boundary conditions in a project. This means that in the programme phase provisions must be described in the ToR to execute all necessary activities for commissioning (like BEMS, measuring points, balancing provisions, provisions for scheduled maintenance etc. etc.). In 1 can be stated who will be responsible for organising commissioning (as described in 0) in the programme phase and in following phases and which other parties should be involved. In 2 can be described during which phases which parties should discuss commissioning, what kind of meeting(s) are necessary as well as the deliverables of the meetings.

Very important is 3, in a direct way as well as in an indirect way. Indirect means that proper specifications and the understanding that a principal knows what he asks and what he gets (i.e. that the specifications meets his expectations) is the beginning of good commissioning. Of course all necessary provisions for commissioning (mostly needed in phase IV and V) must be specified already in phase I. Of special concern is specification of components and provisions that allows maintenance and cleaning.

II Design phase:

In the design phase all necessary provisions for commissioning must be taken into account in the final design and specifications.

III Elaboration:

In the elaboration phase final selection of provisions for commissioning are selected. This means that component specifications must be given under 3 and selection criteria and methods for components must be given under 4. Purchase costs must be reported and guarded under 7.

Special concern is that for the final selection of components special requirements must be given to allow maintenance and cleaning. For example, if a hybrid ventilation concept contains metal ducts special requirements must be given for duct joints to avoid clogging and to allow cleaning (no screws!). Hybrid ventilation provisions in the facade must be selected such that cleaning is possible without the risk of destroying the controls and mechanisms or without the change to disturb adjustments..

IV Realisation:

In this phase actual commissioning takes place. This means that in 1 the organisation of the commissioning must be arranged (i.e. definition of responsibilities, who is doing what, commissioning authority/organisation, installers, etc.). If specialist and external expertise must be hired in it must be reported under 5. Under 2 is arranged if meetings to arrange and discuss commissioning and commissioning results are necessary.

Directives and guideline values are reported in 3. Tools, instruments, checklist procedures, measurement methods etc. etc. are listed in 4. Guarding of planning and costs are described in 6 and 7. In 8 is precisely described how the commissioning results must be reported and documented; (note; in 2 the authorisation and approval of these reports is arranged).

V Operation:

In the operation phase the continuous commissioning process is arranged. Although the organisation and management structure that was operational during a building process is not available anymore in the operational phase the organisation of the continuous commissioning can be described. It clearly will be another organisation and management structure then reported under I – IV. The tools and instruments as described under 4 will be partly the same as described in phase IV. Special attention in phase V is needed for maintenance. This also includes schedules for maintenance, to be reported in 6, and costs (i.e. cost reservations), to be reported in 7. As in phase IV precisely described commissioning results must be reported in 8.

Note that this description only gives a preliminary idea how to arrange and organise commissioning in a logical way in the sequential phases of a production process. This structure can be elaborated if necessary. It can also be used to fill in specification sheets on particular places where they are needed. In practice this can often follow from quality control aspect "9 – Experiences".

2b.1d Reliability

- What experience/statistics is there on reliability? on component level, and system level
- How to make systems more reliable, e.g. immune to balancing problems, and balancing-creep during lifetime

Ventilation reliability can be defined in a number of ways. From a scientific point of view, reliability is expressed as a probability that something is working in an acceptable way (or better). There is also a time-dependence involved. Most mechanical components are torn over time and finally, components break down or perform less and less good until the performance is unacceptable.

Ventilation reliability means - in general - the probability that the chosen ventilation system performs in an acceptable way for a certain building in a certain climate between scheduled maintenance measures. Following aspects concerning reliability can be discriminated:

- Reliability as indicated by air flow rate stability
- Reliability as indicated by performance over time

In order to understand the meaning of ventilation reliability it is important to realise the difference between the reliability behaviour of a "perfect" system and a system under influence of ageing. It is not necessarily so that the "perfect" system creates a reliability of 100 %. The principal influence of situational factors on reliability are shown in table below for different ventilation strategies.

Table 9 *Situational factors influencing ventilation reliability*

Factor	Degree of influence				
	Natural ventilation		Mechanical ventilation		Hybrid ventilation
	Window airing	Passive stacks	Mechanical exhaust	Mechanical supply/exhaust	
Climatic conditions	Strong	Strong	Moderate, especially regarding distribution of ventilation between rooms	Strong, if the envelope is untight	Moderate
Air tightness of building envelope	Strong	Strong	Small	Strong, if the envelope is untight	Strong
Window airing user patterns	Extremely strong	Strong	Strong, especially regarding distribution of ventilation between rooms	Strong	Strong
Outdoor air supply devices	Strong	Extremely strong	Strong, especially regarding distribution of ventilation between rooms	n/a	Strong
Central fan flow rate	n/a	n/a	Extremely strong	Extremely strong	Moderate
Local fans in kitchen and bathroom	Strong, for kitchen and bathroom	Strong, for kitchen and bathroom	Strong, for kitchen and bathroom	Strong, for kitchen and bathroom	Strong

System and component factors

Ventilation systems, especially advanced hybrid ventilation systems, are subject to ageing of its components as well as fouling, user manipulation etc. Thus, it is apparent that the risk for break-down of components such as fan motors, bearings, belts etc increases with the time the system is used. This is normally discussed in terms of life-times. Fouling of ducts and components is also a critical issue regarding reliability of ventilation systems. It is also obvious that there are close links between maintenance intensity, the quality of the components and the reliability of ventilation systems.

Table 10 *In IEA Annex 27 a ranking system was developed for the reliability of ventilation systems. Score based on the fraction of time the flow rate is kept within limits*

Fraction of time with acceptable flow rates	0.00 ~ 0.06	0.06 ~ 0.12	0.12 ~ 0.25	0.25 ~ 0.50	0.50 ~ 1.00
Assessment	--	-	0	+	++
Reliability Quality	Very poor	Poor	Fair	Good	Excellent

Performance Over the Time

Mechanical ventilation systems are built up by a number of mechanical and electrical components, such as fan(s), electrical motor(s), damper(s), silencer(s), air terminal devices, system(s) for automatic control etc. The way that these components influence the performance of the system can of course be described in a fault-tree analysis. There are principally three different kinds of probabilities to estimate individual events.

Fixed probabilities. These are probabilities which are, in principle, not depending on time. For example power failure can be estimated if you can acquire data on how many hours per year you can expect power failure from the electricity company.

Time-dependent probabilities. These are depending on in which state, i.e. at what time you analyse the problem. The failure intensity for mechanical components, for example, is not the same as long as the component is fairly new compared to when it grows older. Another example is duct-fouling with its consequences of gradually lower flow rates. The fact that failures appear independent of each other over the time and that the failure intensity of individual components are depending on time, implies that a qualitative fault-tree analysis can not be performed as a single one, but be repeated with certain time intervals regarding the time of the use of the system.

More or less unknown probabilities. In the context of ventilation performance, typical examples are events based on user influence. These probabilities are very little known, not only because

people are different, but also that the design of the ventilation system influences the behaviour.

The result of a combination with life time and maintenance intervals can be presented in a figure showing the estimated reliability for the system as a function of time. The result is further evaluated by calculating the mean and minimum value of the reliability for a time span of 30 years. An example is shown in next figure. The result for each system applied in both single family houses and multi family buildings can be summarised in a matrix.

The resulting mean and minimum values (of the reliability for a time span of thirty years) given in the matrixes is then finally evaluated and transferred into a single classification system, the qualitative tool. The interpretation from figures to qualitative values are given in a table. Those figures are transformed into a quality related tool where:

Table 11 Scores used in Annex 27 quality tool

--	Very poor reliability
-	Poor reliability
0	Fair reliability
+	Good reliability
++	Excellent reliability

Table 12 Interpretation from quantitative values to qualitative values

Mean reliability	Minimum reliability									
	0.00 ~ 0.09	0.10 ~ 0.19	0.20 ~ 0.29	0.30 ~ 0.39	0.40 ~ 0.49	0.50 ~ 0.59	0.60 ~ 0.69	0.70 ~ 0.79	0.80 ~ 0.89	0.90 ~ 1.00
0.00 ~ 0.09	--									
0.10 ~ 0.19	--	--								
0.20 ~ 0.29	--	--	--							
0.30 ~ 0.39	--	--	--	--						
0.40 ~ 0.49	--	--	--	--	--					
0.50 ~ 0.59	--	--	--	--	--	--				
0.60 ~ 0.69	--	--	--	--	--	-	-			
0.70 ~ 0.79	--	--	--	--	-	-	+/-	+/-		
0.80 ~ 0.89	--	--	--	-	-	+/-	+/-	+	+	
0.90 ~ 1.00	--	--	-	-	+/-	+/-	+	+	++	++

Table 13 An example a reliability assessment is given for single family houses as a function of maintenance intensity and system installation quality

System →	Maintenance intensity								
	PSV			Mechanical exhaust			MVHR		
System quality ↓	low	medium	high	low	medium	high	low	medium	high
Poor system	-	+	++	--	-	++	--	--	+
Average system	+	++	++	-	++	++	-	+/-	++
Best practice	+	++	++	+	++	++	-	++	++

2b.1e Features that facilitate easier operation & maintenance

- Keywords: easier cleaning, ergonomics
- Usability of different system types, e.g. fully-automated versus manual control approach, user satisfaction and details that improve this (PC based voting systems).

2b.2 Health & safety

- fire safety (materials, electrical, smoke evacuation)

- e.g. limits on use/exposure of polystyrene in AHUs
- microbial growth in vent. systems. condensate drain from heat exchanger, and air leakage
- features that facilitate easier cleaning: e.g. avoid ducts or make ducts easily cleanable

Ducting must be cleanable. In general this means that easy access must be possible. In some cases the cleaning may take place through a brush pushed through the ductwork system. But also in the process of construction duct without ATD's should be protected from dirt entering the ductwork by simple caps. More information on this item may be found in Improving ductwork [3]

Attention should be paid to other aspects for hygiene such as microbiological growth and condensation in ventilation systems. Condensation must be prevented as much as possible. In case it is unavoidable for instance in heat exchangers for balanced ventilation systems and roof outlets or cowls a proper drain system is a necessity.

Also air leakage of duct work and other components of ventilation systems may cause problems. Leakage within a heat exchanger may cause unwanted migration of odours. More serious is leakage between ductwork for combustion appliances and ductwork for ventilation. In some case this ductwork has a concentric construction. The leakage between the two part of the systems can be critical from the health perspective.

2b.3 Space and location issues

- Flexibility
 - e.g. alteration of room use or floor plan during the life of the building.
 - How can hybrid ventilation systems be tuned to the requirements for the viewpoint of flexibility
(In general: should we address the item of IFD (industrial/flexible/demountable) building in relation to ventilation?)
Pro: IFD leads to cost reduction and flexibility to users' demands. Practical expertise in IFD
- Building layout, services zones
- Size constraints

IFD is a way of thinking. It says "Industrial Flexible and Dismantling" It means that in the live time of a domestic building the owners can change the inside without braking. So in the design of the building we must count with this quality. With mechanical supply and exhaust ventilation we have a problem with IFD. The infrastructure is too huge. Besides, this pipes and accessories are visible and so very sensitive in the judgment of the occupants.

Therefore the use of hybrid ventilation will reduce this problem very much. Therefore the IFD house is a very suitable for hybrid systems.

The hybrid ventilation process is very dependent on the outdoor climate and the micro climate around the building, as well as the internal layout of the building, the possible air flow paths through it and its thermal behaviour (Per Heiselberg, Principles of hybrid ventilation, IEA Annex 35, 2002). The dependence is higher than for mechanical ventilation. The above mentioned factors have to be taken into account in the basic design step. The result from this first step should be a building orientation, design and internal layout that with the selected ventilation strategy makes it possible to really use the natural driving forces (wind and stack effect) at the specific location and which ensures proper air distribution through the building. The earlier in the design process that flexibility is considered the more likely it is that some degree of flexibility can be achieved. A minimum degree of flexibility of a floor plan of an apartment would be that internal walls can be removed or added for bedrooms, living rooms and kitchens. The assumption is then that air is exhausted from bathrooms and kitchens, which have to keep their location, and that there are enough air supply locations to ensure that the rooms requiring outdoor air will always get it. It must also be possible to raise or lower the exhaust air flow.

Flexibility regarding changes in the floor-plan later by the occupant.

Decentral natural inlets and central exhaust hybrid ventilation can be tuned very easily to requirements of flexibility in my opinion. If you use self controlling inlets you can define them at a maximum capacity. If the inlets have the possibility of a very accurate control-mechanism it is always possible to reduce the amount of fresh air. In case the indoor-plan changes, it is

easy to adjust the capacity to a new level. Therefore to be as flexible as possible it is important to "over dimension" the minimum capacity.

Flexibility regarding barriers in the develop-phase.

As far as inlets concerns I think that there are no real barriers to develop any concept you want. If there is no possibility to integrate the inlets in the windows, there is always an other option available by using special inlets in the outer wall itself.

Off course there are some barriers (limits) at the exhaust side. If you use low pressure ducts you need a diameter ductwork as great as possible. These kind of ducts can not be integrated everywhere in the construction. There is also a wish to avoid to much horizontal ductwork to keep the pressure drop as low as possible.

In general I would say that flexibility should be taken into account but will certainly not be the biggest barrier.

Industrial building should be done as much as possible. For as far as the integration of the inlets in the windows and the roof-outlet this should not be a problem. In the Netherlands it is very common that the inlets are build in industrial by manufacturers of window-frames.

Because of the importance of low pressure ductwork there should be advantages in industrial building for this part as well. This however is much more difficult. For horizontal parts it is possible to integrate them into floors, but for vertical parts it will be difficult to build them in industrially. This should get some attention to see weather we can come up with some solutions.

As far as demountable building concerns we have only experience with aluminium and plastic parts of inlets. As we all know these parts are fully recyclable. The aluminium is very easy to separate from other materials like plastic which are used in inlets. Weather it is financially interesting is off course another question. For electronic parts I do not think there is much future in demountability.

Recycling aluminium and plastic is at this time already daily business in the Netherlands. Therefore I dont believe this should get extra attention at this point.

2b.4 Economic impact of ventilation systems

- List here all the costs/savings related to choice of ventilation system
- investment costs
 - fewer/smaller components ?
- running costs
 - reduced fan power
 - results in lower energy demand for climatizing supply air
 - maintenance (reliability) and filter costs

Costs and savings related to the choice of ventilation system:

Costs are one of the main decision factors for the selection of domestic ventilation system. These costs, similar as for other products, can be divided into two major categories – acquisition costs and ownership costs.

The acquisition costs are costs related to the acquisition of the ventilation system. The most visible part of the acquisition costs is the cost of the ventilation system itself (ducts, fans, inlets, control systems, etc.). However, there are other costs associated with the acquisition of the ventilation system like projection costs, installation cost, commissioning costs, etc. The installation costs can be, in some cases, even higher than the cost of the ventilation system itself, since the changes made to the building during the installation can be enormous.

The ownership costs incorporate operation costs and maintenance costs. The operation costs are primarily given by the costs of energies (electricity needed for operation of the ventilation system components, ventilation heat loss/gain, which has to be covered by heating/cooling). The maintenance costs cover activities like cleaning, adjusting, repairing, replacement of components, etc.

From the previous paragraphs one could come to believe that domestic ventilation systems bring only costs and no benefits. The opposite is the truth. The primary goal in design, development and application of domestic ventilation systems is that the benefits were higher than costs. The most important benefit, which a domestic ventilation system should secure, is healthy indoor environment. It is very difficult to evaluate the benefits for human health, achieved by improved IAQ due to domestic ventilation. Recent estimates place the direct health care costs of poor IAQ in the US at \$30 billion, with sick leave and productivity losses adding another almost \$100 billion annually.

First of all the problem of cost in different phases of the lifecycle of ventilation system is existing and a major barrier to innovative systems. In most cases the investment cost for the system comes from a complete other budget than the operating cost. This leads obviously to lost cost investment systems. Nevertheless in real life people have to run and maintain systems. The cost for this is directly for the user. In ideal case everyone should look to life cycle costing and life cycle effects for the environment. The actual situation differs very much from that ideal situation.

In general one might say that the better the design of the system the lower the cost even in terms of life cycle costing.

For the owner or user of the system there are just a few options to reduce cost.

- Running at low fan speed leading often to a poor IAQ situation
- Low maintenance level leading to insufficient functioning of the system in most cases without any notable effect, but leading to bad IAQ situations

For the designer the options are:

- Optimal design values
- Optimal duct lay out to minimise pressure loss
- Energy efficient fan(s)
- Efficient power supply and control units
- Demand control

This above mentioned options does not lead to any insufficiency of the system but the system investment cost increases.

For more information see IEA Annex 27 [4]

??Annex27 relaib

Figure 14 *Influence of different maintenance practices on reliability*

2b.5 Environmental impacts of ventilation

- energy <- pollution & climate change
- HVAC equipment: Materials, waste, recycling

Buildings must be made sustainable i.e. a building must during its life time have a as small as possible impact on the environment. Products are to be judged from a life cycle perspective, where attention must be paid to all impacts on the environment during the entire life cycle. A building will change during its life span and besides it consists of several different components with different life spans. Usually the components of the ventilation system have a shorter life span than most other parts of the building e.g. the structural parts.

A literature study of building service components and systems from a life cycle perspective shows that so far not much work has been undertaken from this perspective concerning ventilation systems (Åke Blomsterberg, Guidelines for performance based mechanical ventilation systems, TIPVENT, 2000). The choice of ventilation system is usually strongly influenced by the costs i.e. usually the investment costs and not the life cycle costs. This often means a ventilation system that just fulfils the requirements of the building code at the lowest investment costs. Important factors relevant to life cycle perspectives are life span, environmental impact, ventilation system changes and cost analysis.

Very often the practical life span of a ventilation system is determined by the time span a building will be used for the current purpose. During design maintainability and flexibility of the

ventilation system have to be taken into account. The reasons for renovation or reconstruction are more often changed needs caused by changed use than too much wear and tear or that the installations have become old fashioned, that spare parts for expiring products only are kept in store for a limited period of time or for other reasons do not fulfil the demands of today.

A straightforward method of calculating the life cycle cost is to calculate the net present value.

3 ENERGY-CONSCIOUS VENTILATION TECHNOLOGY

There is a natural order in which energy-efficiency measures are conducted. The main principle is the *trias energetica*, whereby the energy demand is first reduced, then renewables are utilised to fill in as much as possible of the remaining demand. Finally low-exergy principles are applied to the whole system. This is illustrated in Figure 15. This hierarchy shows the relative importance of different energy performance indicators, and is the main foundation of this chapter.

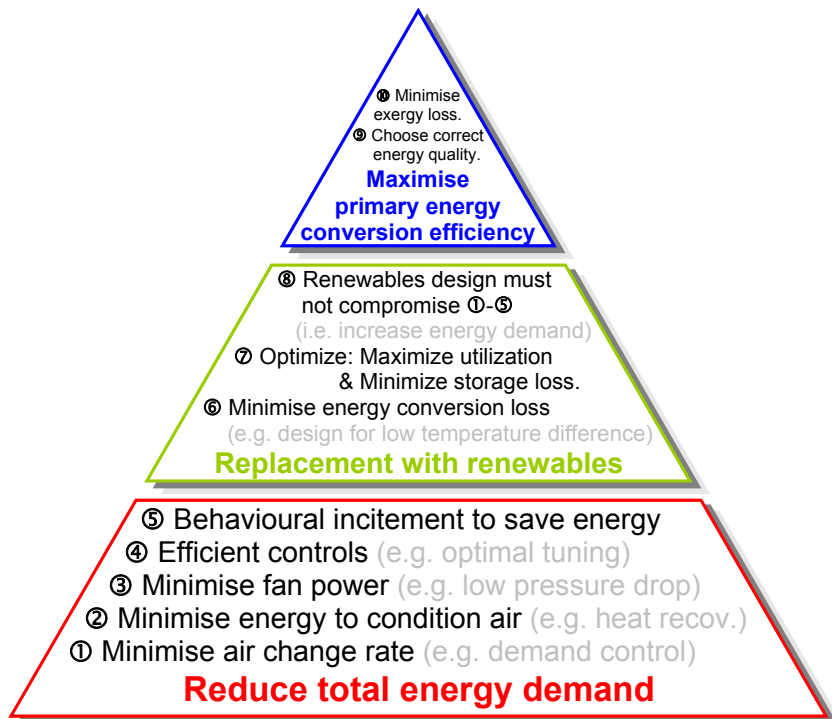

Figure 15 Hierarchy of energy conscious design principles for ventilation.

3a Energy-efficient ventilation principles & components

This section deals with how to minimize energy consumption related to ventilation

3a.1 Minimise air change rate, i.e. minimise ventilation flow rate needed for air quality and cooling:

3a.1a Source control (reduction & containment):

Air quality:

- Conscious use of low-emitting building materials & furnishings
- "Clean building construction" process:
i.e. routines to reduce dirt in house, prevent moisture uptake in construction phase
- Also optimal location of fresh air inlet (avoid sucking in dirty air near street level)
- Stop ventilation (or minimize ventilation) when outdoor air is heavily polluted: if IAQ is better than outdoor air

Conscious use of low-emitting building materials & furnishings

The building materials are considered to be the principal sources of indoor air pollutants in addition to those caused by humans and their activities. Ventilation flow rates needed to meet indoor air quality requirements can be reduced if the emission from building materials and furniture is minimised. Emission from building materials is due to solvents, additives necessary for the manufacturing process or for the optimizing the service properties of each specific material, process residues or chemical reactions in the materials during the processing or a

result of mishandling of them during the building phase, faulty planning of structures causing chemical attacks on materials resulting in irreversible emissions due to degradation. Before installing a material, it should be protected from material degrading environment such as moisture, heat and light. The specifications of the manufacturer concerning the resistance against these environments must be considered. An emission classification such as defined e.g. in [FiSIAQ 2000] allows the use of low emitting building materials. The requirements of each class covers health and comfort (odour) related emission components. e.g. the emission class M1, the highest quality class of [FiSIAQ 2000], has the following requirements:

- The emission of total volatile organic compounds (TVOC) shall be below 0,2 mg/m²h. A minimum of 70% of the compounds shall be identified.
- The emission of formaldehyde (H₂CO) shall be below 0,05 mg/m²h.
- The emission of ammonia (NH₃) shall be below 0,03 mg/m²h.
- The emission of carcinogenic compounds belonging to category 1 of the IARC monographs (IARC 1987) shall be below 0,005 mg/m²h.
- The material is not odorous (dissatisfaction with odour shall be below 15 %).
- Plasters and tiling products, leveling agents, putty, mastics, fillers, screeds and renders shall not contain casein.

Materials of lower quality emission classes or unclassified materials should be used only in a small amount in a building.

The database SOPHIE (Sources of Pollution for a Health and Comfortable Indoor Environment) is a common activity of participants of the three EU projects AIRLESS, MATHIS and "Database for Indoor Air Pollution Sources in buildings" sponsored by the JOULE Programme. SOPHIE is a tool with which emission data and toxicological information of building materials and HVAC components can be retrieved. [Bluyssen 2000]

A relevance matrix of different pollutants and preferred methods of control in different indoor environments has been published in [ECA 1996].

"Clean building construction" process, i.e. routines to reduce dirt in house, prevent moisture uptake in construction phase

Moisture accumulation into building structures or material may lead to microbial growth on materials causing microbial emissions and other contamination. Construction moisture should be dried as fast as possible. Unnecessary wetting of materials during storage and construction phase should be avoided. The control of moisture and water removal during construction has a decisive effect on attaining the desired indoor climate. Good construction site planning has a crucial effect on the control of indoor air risks. The control of water, moisture and cleanliness has to be monitored at the construction site. A moisture control plan must be included in the quality control plan of the construction site. Such a plan can be found in [Lumme 1999], [ISIAQ 2002], [FiSIAQ 2000]

Also optimal location of fresh air inlet (avoid sucking in dirty air near street level)

[Limb 1995] has summarised research into the positioning of air intakes to avoid contamination of ventilation air. The location of ventilation air intakes is of vital importance to the quality of the air that is circulated throughout a building. Contamination of this air, even before it becomes fully ingested into the buildings' ventilation system can occur for a number of reasons. The most important and far reaching of these, are those relating to the complex nature of environmental airflow around buildings. The site specific nature of this problem makes it difficult to produce generalised guidance. Sources of pollution can be exhaust stacks in the neighbourhood, adjacent exhaust air outlets as well as vehicular pollutants. A further consideration is that of poor maintenance, which can result in air intakes becoming clogged, or themselves a source of pollution.

A common barrier when adopting natural ventilation in buildings located in urban environments is the potential exposure to external pollutants. Whilst mechanical ventilation systems can draw air through cleaning filters the driving pressures associated with naturally ventilated buildings are too low. A strategy suitable for naturally ventilated buildings includes, identifying sources of pollution surrounding buildings and positioning air inlet devices in a sensible way [Ajiboye 1998]. An interactive design tool [Demeester 1998] identifies all urban sources of pollution and indicates how different ventilation approaches will determine the type of pollution control features required within air inlets.

In [Liddament 1996] the siting of air intakes are also discussed. It is mentioned that air intakes must be located away from pollutant sources like street level or car parking. The problem of air intakes near car parking areas was investigated by [Limb (1994)]. Although urban air quality can be much improved at above street level elevations, contamination from adjacent exhaust stacks and cooling towers must be avoided. Determining the optimum position for air intakes may require extensive wind tunnel or fluid dynamics analysis. A simplified technique aimed at estimating the maximum concentration of pollutant in the vicinity of a stack emission source has been developed by Wilson for inclusion in [ASHREA 1997] [Wilson 1995].

Climatisation:

- Provide climatisation by other more efficient means than using ventilation air as energy carrier?
 - Here we mean climatisation to offset transmission loss/gain or internal loads, which is in addition to the need for preconditioning air to offset ventilation heat loss/gain.
 - Heating by air at not more than hygienic flow rates is only possible for very highly insulated buildings e.g. Passivhausstandard
 - sometimes using air as energy carrier is the most efficient, e.g. earth coupling
 - What about moisture conditioning ?
- Features that prevent overheating, i.e. minimise cooling load -> minimise fan energy need for cooling broadcast message
 - Optimal location of fresh air intakes (avoid south facade)
 - Limit internal heat loads
 - e.g. good shading & day lighting (e.g. demand-controlled lighting, blinds & light shelf or roof light, deciduous trees outside)
 - e.g. Make use of the air reservoir in a dwelling, e.g. shut of air supply in the hours of max. outdoor air temperatures
 - (outside temp > inside temp.) This is possible when low occupancy density and otherwise low internal pollution loads
 - Passive cooling (free cooling) in dwellings:
 - e.g. (Natural) night ventilation (night cooling / night flushing):
 - high thermal mass in building
 - possibly switch supply fan off when in night cooling mode
 - or is it better to increase airflow rate during night or non-occupied hours (the opposite to minimising air flow, but it is a common night cooling strategy).
 - e.g. Free cooling by water circuit e.g. in concrete slab, and free cooling by cooling tower: This technique presently used only for office buildings

Provide climatization by other more efficient means than using ventilation air as energy carrier. Here we mean climatization to offset transmission loss/gain or internal loads, which is in addition to the need for preconditioning air to offset ventilation heat loss/gain.

To minimise the need for mechanical cooling or heating and reaching the range of passive systems a good control over thermal gains and losses is needed, [Liddament 1996]. Thermal sources of heat gain include conduction through the building envelope, infiltration of ambient air, solar gains through windows as well as internal gains (lights, equipment, occupants). Heat loss can occur during wintertime due to conduction through the building envelope and infiltration of ambient air. In any case heat gains should be minimised by good building design and reduced power consumption in summertime. Whereas in wintertime thermal losses should be minimised and free solar gains maximised. Reaching this targets will be the most efficient way of saving cooling and heating energy.

Examples of thermal source control:

Solar gains – passive solar design: (see also Building Envelope below)

- shading devices

- overhangs or awnings
- tinted or reflecting glass
- trellis
- variable transmission windows
- sunspaces (actual experience: net heat loss?)
- evaporative cooling

Equipment:

- computers
- flat screens
- printers
- efficient lightning
- automatic control of indoor & outdoor lighting
- use of daylighting
- efficient fans for the HVAC-System
- placing all ducted & piped services within insulation envelope, and insulating them (article on insulated truss plenum system in library)

Efficient control system:

- HVAC
- movable shading devices
- lightning

Building envelope:

- extensive insulated of the envelope
- transparent insulation
- building tightness – weather stripping
- thermal mass
- building and window orientation
- light-coloured paints and materials, reflective roofing (article in library)
- low-e, low U-value windows

Surroundings & landscaping:

- vegetation (i.e. deciduous trees)

Heating by air at not more than hygienic flow rates is only possible for very highly insulated buildings e.g. Passivhausstandard

To allow heating by air at no more than hygienic flow rates, a very low heating power demand is necessary. This is because

1. Air as a heat carrier has a limited capacity, and
2. An air heating system cannot compensate for radiation asymmetries.

The heat released to rooms is limited by the total supply air flow rate and the maximum allowable supply air temperature. Assuming a nominal air change rate of 0.3 1/h to 0.5 1/h (about 1 m³/(h.m²)) and a maximum supply air temperature after the air heater of about 50°C, the maximum heat delivery to rooms is approximately 10 W/m² (living area), see figure.

This means, transmission and infiltration losses must not exceed 10 W/m². This requires U-values of walls of 0.1 to 0.15 W/m².K, and a nL50-value of 0.6 1/h. If in addition window U-values are below 0.8 W/m².K, the surface temperatures are close to room air temperatures (at maximum 0.5 K difference for walls, and 3 K difference for windows) and radiation asymmetries are negligible. [IEA 2005]

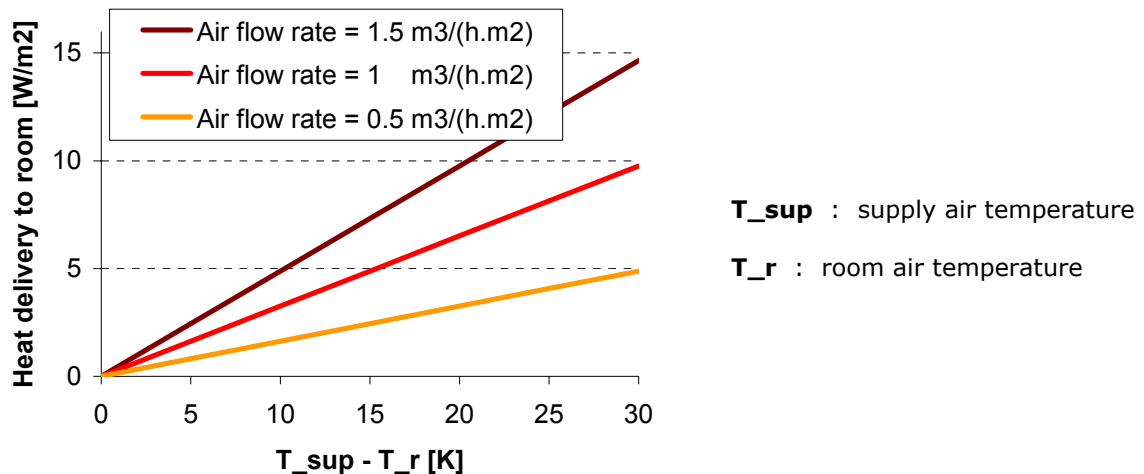

Figure 16 Heat delivery to room with supply air

Sometimes using air as energy carrier is the most efficient

In some cases using air as an energy carrier for space heating or cooling can be very useful. Night cooling by natural driven ventilation is one of the most known example of efficient cooling by air. The Central Europe climate is suitable for natural ventilation but the efficiency depends on the strictness of the control strategy and is limited by high daytime air temperatures.

In regions where the air is dry in summertime evaporative cooling systems can be an efficient way of cooling air. Because of the increase in relative humidity direct adiabatic cooling systems are unacceptable for Central Europe where the outside air humidity is already quite high during the summer. On the other hand indirect evaporative cooling systems which humidify the exhaust air can be installed. In this system the cooling energy is transmitted due to an energy recovering system to the supply air. The cooling potential of such systems highly depends on the difference between dry- and wet-bulb temperature.

Ground coupled fresh air intake ducts are another way of precooling or preheating air. The ground acts as an energy storage which reduces the daily as well as the seasonal fluctuations. The main usage of this system is focused on the summertime to precondition the intake air. Because the preheated air in wintertime reduces the effect of the heat recovering system the main advantage is much more the frost-proof. All these systems are described more in detail by [Zimmermann 1999]. Instead of ground coupled fresh air intake ducts also rock bed storage systems can be used in order to precondition fresh air.

Moisture conditioning (i.e. control of RH)

Condensation of high indoor air humidity can lead to a damage of the construction or to bad IAQ because of microbial emissions. Prevention of high relative indoor air humidity is therefore a very important issue. Ventilating out an excess of moisture leads to an increase of the ventilation heat loss. Therefore from an energy saving point of view, the control of humidity sources should be the first measure. Preventing the spread of humidity with a local exhaust (cooker hood and bathroom exhaust) will also reduce the demand on ventilation and thus ventilation heat loss.

Air conditioning with dehumidification of humid outdoor air is expensive and energy consuming and there are health questions related to hygienic problems in the dehumidifier. In hot and humid climate the outdoor air can be cooled and dehumidified in an energy efficient way with an air washer (enthalpic cooling) [Sprenger 2001]. The energy efficiency of humidity control in hot and humid climates is higher with a displacement ventilation system than with mixed ventilation. This is because displacement ventilation shows a humidity gradient in the room air [Kosonen 2002].

Features that prevent overheating, i.e. minimise cooling load -> minimise fan energy need for cooling broadcast message

Optimal location of fresh air intakes (avoid south facade)

It has to be considered that the air temperature above wind sheltered squares or places which are exposed to intensive solar radiation can be up to 15 degrees higher than measurements at the weather-station. Also solar gains on south facades may cause an upwards air movement caused by thermal buoyancy. The preheated outside air from this boundary layer can reach into the building by poor placed air intakes or opened windows. The influence of this phenomena and optimal air inlet designs has been discussed by [Finke 2002]. It has been found, that higher velocities at the inlet and round duct design minimise the air volume flow from the this heated layer.

Also the landscape near the air inlet has an influence on the air quality. As described by [Allard 1998] the type and layout of vegetation to be included in a site plan should be chosen with the airflow pattern taken into account. Not only the air movement, but also the quality of air, is affected by vegetation. Though the effects of shading and transpiration, the heat content of the ambient air crossing a vegetation barrier decreases, while the humidity of the air increases. This process induces an air cooling effect. In addition, vegetation reduces noise, removes dust particles, absorbs carbon dioxide and introduces oxygen into the air.

Limit internal heat loads.

e.g. good shading & daylighting (e.g. demand-controlled lighting, blinds & light shelf or rooflight, deciduous trees outside).

Provide climatization by other more efficient means than using ventilation air as energy carrier.

Here we mean climatization to offset transmission loss/gain or internal loads, which is in addition to the need for preconditioning air to offset ventilation heat loss/gain.

e.g. Make use of the air reservoir in a dwelling, e.g. minimise air supply in the hours of max. outdoor air temperatures (outside temp > inside temp.) This is possible when low occupancy density and otherwise low internal pollution loads

The rise of the pollutant concentration in a room without ventilation depends on the relation of the pollutant source strength to the room volume. Reaching the threshold values of the pollutant concentrations will need a long time in large rooms with small pollutant sources. Compared to other buildings, dwellings have a low occupancy density. If in addition also the pollutant loads from building and furniture materials are low, this storage capacity of the room air can be utilized: The supply of fresh air can be minimised during periods when the outdoor temperature is higher than the room temperature. After such a period the ventilation flow rate must be increased in order to purge the room. This will reduce peak room temperatures.

Passive cooling (free cooling)

Phase change materials?? (salt)

high thermal mass in building

The use of the thermal mass of a building allows to reduce the diurnal temperature variations in the building. It allows also to shift the cooling load into night time when the cooling potential of the outdoor air is at a maximum. The capacity of the thermal mass is loaded during the day time when the heat gains are at a maximum and unloaded during night time e.g. with increased night ventilation. To be fully effective the thermal mass must be exposed. That means suspended ceilings, raised floors or a high resistance of e.g. the floor-covering will reduce the effectiveness of the thermal mass [NatVent 1999]. Several control strategies for night cooling to optimize either energy or cost savings with both, mechanical and natural ventilation are described in [Martin 1995] and [Martin 1996].

possibly switch supply fan off when in night cooling mode

[Martin 1996] concludes from modelling results that if the average natural ventilation rate is 4 ac/h or above the benefit of supplementary mechanical ventilation would be marginal. Also in monitoring studies he found: night cooling, in general, is not more effective with mechanical ventilation than natural ventilation. Thus night cooling by mechanical ventilation, although a useful backup, should be limited to selected conditions e.g. bad weather preventing the use of natural ventilation or if the situation does not enable enough natural ventilation (e.g. single sided ventilation with a small open area).

or is it better to increase air flow rate during night or non-occupied hours (the opposite to minimising air flow, but it is a common night cooling strategy)?

From the conclusion above it is clear, this strategy will only bring a benefit if natural ventilation is below 4 ac/h. Otherwise the fan energy consumption increases without to improve the effectiveness of the night cooling.

e.g. Free cooling by water circuit e.g. in concrete slab, and free cooling by cooling tower: This technique presently used only for office buildings

In contrast to conventional chilled ceiling panel cooling systems, thermally active building components, such as slabs act as a thermal energy storage. Waste heat from occupants, office equipment or solar gains during the day will be stored in the building structure. During the night, water which is cooled by the night air (cooling towers) flows through the embedded plastic tubes and cools down the building structure. As a result it is possible to condition the building without a mechanical cooling machine [Koschenz 2000].

3a.1b Maximise ventilation efficiency:

Energy efficient ventilation addresses both low power use for the fan(s) and accurate and precise ventilation flows according to the demand and thus minimising heating/cooling. In domestic ventilation systems for cold climates the heat demand for the ventilation is about 20 times higher than electricity use for the fan if efficient exhaust fan systems with low specific fan power (SFP < 0.7 kW/ m³/s). Accuracy and precision are both essential.

Good practise for getting better precision in central ventilation systems for multifamily building in Sweden is constant pressure regulation and low pressure drops in duct works. That is one way to prevent changing in one department to affect the others. In combination with outdoor temperature compensation that is lessening the air flow at low temperatures compensates for thermal pressure. This is the dominating practise today.

Low pressure drops in the ventilation system is system depending. Low system pressure down to 70 Pa total external pressure drops in exhaust ventilation systems is measured for recent built four storied multifamily blocks and SFP will then come down to 0.4 kW/ m³/s (reference: MEBY project¹). Forced ventilation flows when cooking is then supported by an extra cooking hood fan.

Even lower pressure drops will result in bad precision, as the variations in thermal pressure will differ from ground floor to upper floors. And precision is more important than getting even lower SFP at this low level.

Demand controlling is the great potential for energy saving if not heat exchanging to supply air. Demand controlling from 0.6 l/s·m² (forced air flow when cooking) to the level of 0.1 l/s·m² floor area (when not occupied) will in theory result in a reduction of the total pressure drop from the 70 Pa to almost zero if no system changes. Demand controlling in combination with low-pressure drop systems will result in very bad precision if not addressing these problems. Compromising might be needed. (results from IC1)

Spatial efficiency:

- Displacement ventilation:
 1. Global displacement ventilation (cascade flow): e.g. supply in bedroom; living room is on the flow path to the bathroom exhaust
 - (this a passive version of zonal DCV)
 - In Switzerland this type of air distribution in the dwelling is called "cascade type" air distribution.
 - For many, displacement ventilation is more related to the plume generating character of the user of fresh air,
 - and has less to do with the distribution of fresh air from room to room due to the location of supply & exhaust devices,
 - but it is correct to address the issue of whole-building or whole-dwelling ventilation efficiency.

¹ MEBY-project homepage: <http://www2.stockholm.se/lip/index.asp?a=6&b=16>

- 2. Zonal displacement ventilation: low-velocity displacement ATDs for supply to occupied zone in bedrooms & living room
 - what are pros & cons, e.g. draughtiness, cost, how to prevent these problems
 - what do building regulations say about global and zonal displacement ventilation ?
- Minimise short circuiting:
 - Between supply and extract points (equivalent to displacement ventilation):
 - buoyancy effects (warm supply air hangs near ceiling ?)
 - This depends on diffuser type. With high induction this effect is less, but pressure drop is high and thus is not energy efficient.
 - Flow between exhaust air and fresh air intake
- Ductwork airtightness
 - results from SAVEDUCT, LBNL study
 - What is "good practice" for ductwork airtightness ?
- Better building ext./int. airtightness as a means of improving ventilation efficiency - so air flows where you want it to.

Introduction to spatial ventilation efficiency

Despite of the fact that the flow rate is in accordance with the ventilation standards and the lack of thermal bridges, mould growth, i.e. in bathrooms, arises frequently. This can be caused by a short-circuit flow of ventilation air. Air that is supplied at the lower end of the door is exhausted almost immediately through an exhaust device in the ceiling, nearby the door. Moisture remains in the room and causes mould growth. The efficiency of the ventilation system with respect to the removal of the produced moisture is insufficient. Literature study gives a limited number of criteria for ventilation efficiency. It is important to make a distinction between the replacement of "old polluted" room air with clean air and the removal of pollutants from the room to prevent them from spreading to the occupied zones. In habitable rooms, ventilation is particularly used to replace polluted room air. In service rooms, such as kitchen and bathroom, the objective is to remove produced moisture or odour rapidly. The usefulness of the different criteria for evaluating ventilation efficiency in dwellings is marked based on six qualifications, which are worked out for several types of ventilation systems.

Ventilation efficiency, ε

$$\varepsilon = \frac{C_e}{C_r} \quad (2)$$

C_e Concentration of pollutants in the exhaust duct [gravimetric or volumetric fraction]

C_r Mean concentration of pollutants in the occupied zone [gravimetric or volumetric fraction]

ε does not provide direct information about air quality (concentration of pollutants). C_e is not constant, but is influenced by C_r . ε is specifically meant for the determination of the efficiency of a local exhaust system. When as a result of (local) natural cross-ventilation C_e decreases relatively more than C_r , ventilation efficiency will decrease, while air quality in the occupied zone increases. By measuring the concentration of pollutants on several points, it is possible to show the mean concentration of pollutants as well as local concentration differences. Since ε is measured in equilibrium condition, ε does not offer insight into dynamic exhaust behaviour of the ventilation system.

Contaminant removal efficiency, η

$$\eta = \frac{C_e}{C_e + C_r} \quad (3)$$

In principle the same remark goes for η as well as for ε .

Capture efficiency, S

$$S = \frac{C_e}{q/Q} \quad (4)$$

q Pollutant flow rate [m³/s]
 Q Exhaust flow rate [m³/s]

There is no relation between S and the concentration of pollution in the occupied zone. Therefore, S is an evaluation of the functioning of the ventilation system and not a validation of air quality as a result of this ventilation system. I.e., by using natural cross-ventilation air quality in the occupied zone can improve strongly, while S remains nearly constant. Due to the fact that no concentrations are measured in the occupied zone, it is not possible to establish concentration differences. S is measured in equilibrium condition. Dynamic effects are not taken into account.

Removal efficiency, η

$$\eta = \frac{\sum Q_e}{\sum Q_r} \quad (5)$$

$\sum Q_e$ total pollutants mass exhausted [kg]
 $\sum Q_r$ total pollutants mass supplied [kg]

During the determination of η the total pollutants mass exhausted is related to the total pollutants mass supplied. There is no direct relation between η and the air quality in the occupied zone. During natural cross-ventilation, a part of the pollutants will be blown off outside of the local exhaust system. As a result $\sum Q_e$ will decrease and air quality will improve but η will decrease. Due to the fact that the total pollutants mass exhausted off is measured in the exhaust duct, it is not possible to determine (local) concentrations. Because the total mass of pollutants exhausted is measured from the beginning, dynamic changes are taken into account when determining η .

Collection efficiency, CE

$$CE = \frac{C_r}{\frac{q}{Q} \left[1 - \exp\left(-\frac{Q \cdot t}{V}\right) \right]} \quad (6)$$

t time [s]
 v room volume [m³]

The mean concentration of pollutants in the room that occurs during the working of a local exhaust duct, will be related to the concentration that occurs by complete mixing. Therefore, in spite of the constant concentration of pollutants, CE changes if room volumes or flow rates will vary. CE gives only an indication of air quality as a result of the ventilation system. Because there is a direct link (non-linear) between CE and the concentration of pollutants in the room, the influence of natural cross-ventilation in the room will be expressed by the CE value. The mean concentration of pollutants will be measured 10 minutes after starting the pollutant production by mixing the air and followed by measuring the concentration of pollutants. The mean concentration of pollutants is measured in the room, not in the living area. Concentration differences are not measured. The mean concentration in the room results from the preceding production of pollutants and the exhaust process. Therefore dynamic variations are taken into account.

Pollution index, PI

$$PI = \frac{C_r}{\frac{q}{100} \left[1 - \exp\left(-\frac{100 \cdot t}{V}\right) \right]} \quad (7)$$

PI is in the same way defined as CE , except that for the exhaust flow rate a value of 100 m³/h is fixed.

Room Pollution Index, RPI

$$RPI = \frac{Cr}{q \cdot t/V} \quad (8)$$

The pollutant concentration in the room is related to the concentration that will occur if no pollutants would be exhausted. Therefore there is a direct (linear) coupling between *RPI* and the concentration in the occupied zone. Because of this, it is possible to take into account the influence of cross-ventilation when evaluating ventilation efficiency. Comparing *RPI* from rooms with different volume has no practical meaning, because the frame of reference changes. This also fits for *CE* and *PI*. Local differences of pollutants concentrations can be detected if the concentration will be measured at several well chosen points in the occupied zone. Dynamic behaviour of the concentration is taken into account and will be depending on the total measurement time.

Ventilation efficiency criteria for habitable rooms

Nominal time constant, *Tn*

$$Tn = \frac{V}{Q} \quad (9)$$

Tn is defined as the quotient of the room volume and the flow rate. It is reflecting the time it takes to supply the room with an amount of air as much as the volume of the room. Air quality can be judged roughly by determining *Tn*, on condition that the air flow pattern in the room is not a short circuit flow. If *Tn* decreases the room will be faster flushed with outdoor air. Therefore air quality will improve. For short circuit flow the supply air will move directly to the exhaust point. Outdoor air is not mixed with polluted air in the room and instead of polluted air, outdoor air is exhausted. Because there is a direct link (non-linear) between *CE* and the concentration of pollutants in the room, the influence of natural cross-ventilation in the room will be expressed by the *CE* value. The mean concentration of pollutants will be measured 10 minutes after starting the pollutant production by mixing the air and followed by measuring the concentration of pollutants. The mean concentration of pollutants is measured in the room, not in the living area. Concentration differences are not measured. The mean concentration in the room results from the preceding production of pollutants and the exhaust process. Therefore dynamic variations are taken into account.

Air change efficiency, ε

$$\varepsilon = \frac{Tn}{Tr} \quad (10)$$

ε shows how fast air in the room is changed compared with the shortest possible lingering time of air in the room, *Tr*. If *Tn* and *Tr* are known ε can be determined. Air quality is improved if ε increases. The best air quality will be obtained by piston flow, $\varepsilon=1$. With complete mixing of air in the room, the value of $\varepsilon=0.5$. If no air is exhausted out of the room air quality is poor (short circuit flow) and $\varepsilon=0$. ε can be determined for all types of systems and flow pattern. Because the *Tr* can be determined by measuring concentrations of pollutants at several points in the room, local differences in concentration can be shown. Dynamic effects are not taken into account.

Qualifications of efficiency criteria

Practical meaning

The main aim of ventilating, airing and exhaust of pollutants is to achieve a healthy indoor air quality in the occupied zones. So it is important that this is clearly expressed by means of the used efficiency criterion. A decrease of the pollutant concentration in living spaces must lead to a more or less equivalent reduction or rise of the criterion value. It is important that the criteria relate to the same frame of reference all the time. This reference has to be unambiguous and physically justified. A reference is not valuable if it does change drawing a conclusion with regard to the functioning of the ventilation system. This also fits the case in which influence parameters (for instance the ventilation rate) are changed and effects of these changes have to be determined.

Combined effects

The main objective of a local exhaust system is to realise a healthy air quality in the living area. However, the local exhaust system is only a tool. So it is more important to evaluate the room ventilation efficiency instead of only the ventilation efficiency of the exhaust system. The benefit of this approach is that also the combination of ventilation systems can be evaluated. If i.e. a kitchen hood is supported by natural ventilation through cracks or windows, the pollutant concentration in the occupied zones gives the only correct valuation of the efficiency of the combination of these ventilation systems.

Local effects

For a healthy indoor air quality in the entire occupied zone large local deviations are not acceptable. By using only an average efficiency value for the whole living zone one has to deal with loss of information and incorrect judgement concerning the functioning of ventilation systems.

Dynamical approach

Normally the concentration of pollutants in habitable rooms is in balance, which makes a stationary approach possible. This does not fit for the removal of pollutants in service rooms. During the period of i.e. preparing a meal, taking a shower or a bath the moisture or smell concentration does not always attain a stationary level. So in this case it is important that the criterion also is applicable for non stationary approach, in which the efficiency value varies in time.

Measuring method

Accordingly as the measuring method to determine the ventilation efficiency becomes simpler, the practical applicability of the criterion increases and it takes less time to measure.

Measuring tools

Accordingly as the required measurement tools are simpler and less expensive the practical applicability of the criterion increases.

Evaluation efficiency criteria

For seven distinguished ventilation systems the practical applicability of the investigated efficiency criteria is evaluated and presented in a table. Thereby difference is made between habitable rooms and service rooms.

Conclusions and recommendations

The use of a room is determining the choice of a criterion for evaluating ventilation efficiency. Therefore, a distinction is made between habitable rooms and service rooms. For both types of rooms, efficiency criteria in which air quality or the pollutant concentration is to be expressed are the most suitable. In fact using these criteria the type of ventilation system or combination of several ventilation systems is irrelevant. An important issue concerning the efficiency criterion is the frame of reference. Preferably, this has to be constant. This means there have to be made agreements about example measurement time, production of pollutants etc. Also there have to be made agreements about the measurement procedure and assumptions for the simulations.

Temporal efficiency (Demand-controlled ventilation):

1. Global DVC : e.g. reduce to 0.25 ac/h when whole building is empty
2. Zonal DCV : e.g. bathroom sensor for controlling bathroom extract.
 - e.g. In Switzerland, WC and bathroom extract fans are connected to light switch, triggering a fan operation of about 3-5 min
 - e.g. Aereco humidity controlled inlets
 - e.g. Alusta electronically regulated inlets
3. Local DCV : e.g. kitchen hood only operates when cooking, else sealed for leaks; closable fireplace damper
 - which control parameters should be chosen? e.g. occupancy, CO₂ , %RH

- this ties in with questions of behaviour in relation to DCV: i.e. will the occupants accept or activate DCV if no incitements, e.g. if no individual energy metering
- it also ties in with the types of pollutant sources: Moisture from people washing etc, Smell from WC, cooking, Building materials, Smoking, Outdoor pollution, Radon, Combustion

What do building regulations / EPC say about DCV ? (both temporal & spatial)

1. Global demand control

- As the aim of ventilation is mainly to provide fresh air for occupants, it seems reasonable to allow to stop ventilation when no occupants are present in **the whole building**. However, as the building itself is a pollution source, it is preferable to remove its pollutants immediately. Therefore, the ventilation should not be stopped but reduced.

Target value could be, for instance, 1.3 or 2.5 m³/h.m² (which are the rates for rooms not designed for human occupancy corresponding to IDA3 and IDA2 in prEN 13799).

2. Zonal demand control

- The same logic applies for **rooms**. If no one is present in the bathroom, for instance, it seems logic not to extract air from the bathroom (excepted the minimal airflow for the building pollutants). The ventilation should not be reduced immediately after the user departure, but a few minutes after. The control could be linked to light switch, or to a sensor (presence, humidity, CO₂,...); the sensor could also be integrated in the inlet (see AERECO humidity controlled inlets (§ 3a.4a) or ALUSTA electronically regulated inlets).

For instance, in Belgium (in some cases): after 3 the fan has delivered 3 air changes. This time can be limited to 1800 seconds.

However, this strategy can not be applied in all wet rooms, regardless to habitable room (living, bedrooms). Indeed, if all occupants are in habitable rooms, the fresh air supplied there has to be extracted from somewhere, at least partially (depending on the building airtightness and the allowed overpressure). The same applies when all occupants are present in wet rooms: fresh air has nevertheless to be supplied in habitable rooms.

3. Local demand control

- The third level is **local extract**. In a dwelling, this is mainly kitchen hoods. As such devices aim to remove pollutants where they appear, it seems logical to run them only when pollution is produced. This can be done by the user and a on/off switch or by a control sensor (e.g. humidity for kitchen hood). In such cases, the device is designed for intensive ventilation during limited period. It should not be regarded as a component of the base ventilation system, unless a minimum airflow can be achieved.

For instance, the Belgian standard states "cooking hoods that work intermittently can not be described as mechanical ventilation system and are not taken into account during the calculation described in the present standard".

How do Energy Performance Regulations deal with Demand Controlled Ventilation?

Though most of the national standards and/or regulations require airflow rates for specific rooms, not all of them address the aspect of control or even can be barrier to a demand control strategy. For instance, in Norway, a constant minimum air change rate of 0.5 air changes per hour is specified, even when the dwelling is unoccupied. In Belgium, it is specified that "the air inlets/outlets may be equipped with a control system related to wind pressures, CO₂, or humidity", but do not specify any kind of strategy (excepted that, strictly spoken, mechanical ventilation can not be turned off).

In The Netherlands and in Belgium, the energy consumption for ventilation is related to a fixed airflow (standard values for dwellings, design values for other buildings). DCV is not included in the procedure. If someone wants to take advantage of DCV, he must assess its performance with the "principle of equivalence".

In France, the airflow rates can be reduced by a coefficient, according to the control strategy: 0.9 for presence detection and 0.8 for CO₂ sensors.

- o O o -

The controlling system might depend on sensors and activators or human behaviour. Sensors and other technically sensitive systems might have an important drawback: bad maintenance (if depending on the occupants maintenance), expensive maintenance (if professional) or no maintenance at all if placed in the flat and not easy accessible for the staff.

Depending on human behaviour demand behavioural knowledge and incitements. For domestic areas CO₂ will be of less relevance as odours or humidity will be of greater importance.

Humidity controlling might be either manually controlled or RH-controlled (both alternatives are typical in one-family houses), but not using building regulation air flows probably means RH-sensors will be compulsory.

Occupancy control can be automated with more advanced door-locking systems related only to outside locking (reference building in Stockholm). Manually controlling has to be combined with economical incitements and thus individual energy metering. For metering energy use for heating in well-insulated buildings the heat loss method (indoor temperature) is preferable, but has to include measuring of the ventilation flows as this will vary according to the demand.

The base ventilation need according to the number of persons per dwelling might easiest be set by the inhabitant them selves. If this will result in best satisfaction level compared to regulated fixed air flows with no correspondence to the number of inhabitants has to be tested.

Shifting inlet air from sitting room to bedroom at night-time: automatically by a time-controller (IC1)

3a.2 Minimise energy needed to condition required supply air

(i.e. minimise energy used to offset ventilation heat loss/gain, not transmission loss/gain etc.):

3a.2a Features that reduce both demand for heating & cooling supply air:

- Reduce infiltration - to reduce both ventilation heat loss & cooling load
 - better envelope airtightness
 - better internal airtightness, e.g. between floors
- Ground-coupled pre-conditioning of the supply air (diurnal cooling : very effective; seasonal storage for heating : not economical for heating)
- For balanced ventilation systems: Heat transfer into the supply air duct in ducts cast into floor or ceiling slab:
 - Supply air is preheated by slab, thus minimizing draft risk due to cold supply air.
 - However, this does not reduce the overall heating demand, but perhaps peak heating/cooling load requirements
- Heat recovery (enthalpic heat recovery - also provides cooling in summer)
- Duct insulation
 - What is good practice for ductwork insulation - where, thickness and types if insulation

Airtightness

Poor airtightness of the building envelope result in excessive air infiltration/exfiltration and resultant uncontrolled energy loss. In many countries building envelope airtightness can and should be improved considerably. This can be done while maintaining or improving the indoor air quality, if a proper ventilation strategy is implemented. Infiltration/exfiltration is at its highest during winter when the temperature difference between inside and outside is high. This is often, when periods of maximum thermal conditioning occur.

Different ventilation systems require different levels of airtightness of the building envelope. This in order to keep the air infiltration/exfiltration at the same low level. The airtightest envelope is required for balanced ventilation systems, ideally below 1 ach at 50 Pa (Åke Blomsterberg, Ventilation and airtightness in low-rise residential buildings – Analysis and full-scale measurements, Swedish Council of Building Research, D10:1990). A building with exhaust only can be less airtight, better than 3 ach. The reason is that an exhaust only system depressurises the building, which reduces the exfiltration. Buildings with natural ventilation should be reasonably airtight, to able to achieve some degree of controlled ventilation.

There is a large variation in building airtightness depending upon the method of construction and the quality of workmanship. Even what looks like identical buildings can have a very different level of airtightness.

Different leakage distributions:

[Orme 2003] gives some hints how overall air leakage data of a building could be distributed on the building envelope. The simplest approach is to assign a high-positioned and a low positioned leakage path to each façade, together with a roof level path. If more knowledge is available about any construction characteristics, then it may be possible to refine the distribution by taking into account the positions of, for example, doors, windows, and also the construction type of the walls and roof. If sufficient information is at hand concerning both the construction type and quality, individual component air tightness data given in [Orme 2003] may be used.

Percentages of the whole-building air leakages associated with various components and systems are given in table xx [ASHRAE 2001].

Table 14 Percentages of the whole-building air leakages associated with various components [ASHRAE 2001]

Component	Range [%]	Mean [%]
walls	18 - 50	35
ceiling	3 - 30	18
forced air heating/cooling system	3 - 28	18
windows / doors	6 - 22	15
fireplace	0 - 30	12
vents	2 - 12	5

Heat recovery

There are at least five different methods of ventilation heat recovery (Martin Liddament, A Guide to Energy Efficient Ventilation, AIVC, 1996):

- Air-to-air heat recovery.
- Flue gas heat recovery.
- Exhaust air heat pumps.
- Combined air-to-air heat recovery with heat pumps.
- Dynamic insulation.

During warm summer days some of the heat recovery systems can be used for cooling assuming the indoor air is cooler than the outdoor air. During the intermediate seasons there are times when it would make more sense not to preheat the outdoor i.e. have a bypass.

Air-to-air heat recovery

The first method means the heat of the exhausted air is used to heat the incoming outdoor air in a heat exchanger. The air-to-air heat recovery often means that the exhaust air duct and the supply air duct have to be joined at some point in the building (Per Fahlén, Värmätervingning ur frånluft (Heat recovery from exhaust air), Swedish Council for Building Research, R17:1993). There are also run-around coils i.e. the heat is transferred by a fin type heat exchanger to a liquid, which in its turn through a second fin type heat exchanger heats the incoming outdoor air. There are two types of directly coupled heat recovery systems, the recuperative and the regenerative.

The **recuperative** heat recovery unit is typically plate heat exchanger of cross flow type, which means a large heat transfer area relative to a small volume. The heat exchanger is of a simple construction and consists typically of alternating cross located aluminium sheets. The air flow passes between the sheets with exhaust air in every second layer and outdoor air in the remaining layers. The temperature efficiency is typically in the range of 0.6 to 0.8. Recent developments (new materials etc.) have shown efficiencies of up to 0.9. The yearly energy efficiency can be 70 %.

The advantages of the recuperative heat exchanger are e.g. that the air flows are separated, which reduces the risk of reintroducing polluted air. Furthermore the principle results in a compact unit with few moving parts. The main disadvantage is the need for defrosting, which

increases complexity of the unit and usually results in reduced heat recovery. Another disadvantage is a relatively important pressure drop, which increases both the risk of noise and the electricity demand for fans.

In the **regenerative** rotating heat exchanger the heat is transferred through a package of metal sheets, which slowly rotate in a plane perpendicular to the air flow. During half of the revolution the package is heated in the exhaust air flow and during the other half the heat is transferred to the incoming outdoor air. The temperature efficiency is typically higher than for the recuperative heat exchangers.

One advantage is that the thermal efficiency can be controlled by adjusting the rotational speed. Defrosting of the unit is usually not needed. The disadvantages are that the heat exchanger requires support energy, has moving parts and that there is usually a certain (sometimes rather substantial) transfer between exhaust and supply air in these systems. In some cases the transfer consists of unwanted retransfer of humidity, which also means an additional risk of retransfer of pollutants.

The yearly recovered energy in practice is often lower than what the manufacturers promise. For ten Swedish one-family house the recovered energy was 3 Mwh/year instead of the promised 6 MWh/year 5 to ten years after installation (Per Fahlén.....).

The run-around coils have the advantage of totally separating the exhaust and supply air flow, thereby eliminating the risk of cross contamination. The disadvantage is a relatively low efficiency (40 to 60 %).

Flue gas heat recovery

Waste heat is recovered from the flue gases of a gas heating system, using a conventional plate air-to-air heat exchanger. There is a risk of flue gas contaminating the supply air.

Exhaust air heat pumps

A heat pump is employed to recover heat from the exhaust air. The recovered heat is used to pre-heat domestic and/or space heating hot water. Typically an 'air to liquid' heat pump is used in which an evaporator is located in the exhaust air flow, to recover heat from the outgoing air, while a condenser is located in a tank, to boost water temperature. There are many advantages. The heat recovery system does not require a balanced ventilation system. An exhaust air heat can be used in an exhaust only system or a passive stack ventilation. The yearly COP can be rather high, above three. However there are some disadvantages also. Heat pumps are relatively expensive and not always reliable.

Dynamic insulation

The principle of dynamic insulation means that the ventilating air is passed through the building envelope to effectively reduce heat loss through the building envelope. The resulting total heat loss from the building, due to ventilation and conduction, becomes less than that which would be due to ventilation loss and conduction loss. Performance requires very good design and workmanship. Some of the systems can result in condensation of moisture causing damage. The operational efficiency is often lower than for an ordinary air-to-air heat recovery system.

The overall energy efficiency of a heat recovery system will be lower in leaky building envelope, as heat can not easily be recovered from exfiltration.

If the necessary maintenance and cleaning of a heat recovery system is not carried out, the heat recovery efficiency will drop over time and so can also the air flows.

'Ground'-coupled ducts for pre-conditioning

The ventilating air can be pre-conditioned in earth-laid pipes or concrete culverts. In winter these systems use the thermal energy stored in the ground, while in summer the ground can store excess heat from the supply air. The advantage is 'free' heat and coolth from ground sources. The disadvantages are costly installation, risk of moisture/mould problems, maintenance strategy needed.

Duct insulation

First of all, ventilation ducts located in non-conditioned spaces e.g. attic, should be insulated to avoid unnecessary heat loss. There are two ways of insulating ducts, either insulation mats or embedding in loose fill insulation. An un-insulated duct located in an attic can have a heat loss

factor of 1.4 – 1.6 W/m/K compared with 0.10 – 0.25 W/M/K for a duct located in half a meter of loose fill insulation (Per Fahlén, Värmeförluster från luftkanaler (Heat losses from ventilation ducts), SP rapport 1992:21). The heat losses from a poorly insulated (with insulation mat) duct can be 1/3 of the heat recovered from an air-to-air heat exchanger.

3a.2b Features that just reduce demand for heating supply air:

- Zoning : Supply in sleeping rooms may be colder than in living room.
- Interaction of outdoor air inlet and heat distribution elements (radiator, convector, floor heating system) in respect to draft. ?
- Air inlets with self regulating and good air diffusion (along wall with Coanda effect), thus reducing draft risk.
- Section 3b.3b mentions solar preheat systems.

Air inlets – preventing draught problems

A frequent complaint in dwellings is draft from the outdoor air inlets. The occupants will either block the inlets or raise the indoor temperature to compensate for draft. Therefore inlets should be designed to ensure they do not cause uncomfortable draft. Design specifications includes the emission rate, discharge velocity and turbulent intensity. An improvement is to ensure that high air flows due to e.g. wind are avoided. This can be done by installing automatic inlets, which adjust to climate parameters (temperature, humidity, pressure). There are automatic inlets which guarantee a constant air flow. There are also different means of pre-heating the incoming outdoor air. A conventional solution in Northern Europe is to have ventilators located directly behind wall mounted radiators in order to avoid draft during winter.

3a.2c Features that just reduce demand for cooling supply air:

see "Minimum flow rates : Source control : Climatisation", above

3a.3 Minimise fan power

3a.3a Maximise fan efficiency

- Efficient motors, e.g. EC motors (partly handled under controls)
- Efficient impellers, e.g. axial fans

Fan power

The aim is, for a given flow, to minimize the electric consumption. The electric power is given by:

$$P = \frac{1}{\eta_m} \cdot \frac{1}{\eta_f} \cdot Q \cdot \Delta P \quad (11)$$

P	electric power [W]
η_m	efficiency of motor and transmission
η_f	efficiency of the fan impellers
Q	flow [m ³ /s]
ΔP	differential pressure [Pa]

For a typical Dutch house designed according to the Dutch Building Regulations a flow rate of about 42 dm³/s must be supplied and extracted. In case people apply the normal systems available on the Dutch market a reference case for fan power might be about 21 W. In general fans of domestic systems in Holland are in the range of 40 to 50 W. So there is already a difference between what is needed and what is applied. In the Tipvent project [3] has shown that with simple measures the fan power can be reduced to about 7 W. The target in the Reshyvent project for IC2 is a fan power of less than 2 W.

Efficiency of motor and transmission

The efficiency depends on the kind of motor. The different types are given with increasing efficiency.

- **AC single-phase** : generally used in for single family house.
- **AC three-phase** : used in multy storey buildings

- **DC current** : fans with DC motors exist both for single family house and multi storey buildings

State-of-the-art DC-fans in domestic ventilation

DC-motors are commonly standard in energy efficient domestic ventilation applications.

Considering the actually state of the art of DC-motors we cannot expect a significant further rise of motor-efficiency. A further improval of air efficiency is also not expected. Combination of DC-motors and last-generation improved impellers gives total-efficiency up to 43%

(The most actual point is research and testing on different possible solutions for decrease of motor noise and vibration.)

However, the combination with lower resistance of air ducting will decrease the needed fan power. This makes it possible to realize ventilation up to 200-300 m³/h with a consumed fan power under 5 W.

Efficiency of the fan impellers

In general there is no significant difference in DC-motors between European manufacturers. There is a difference in impeller type, which means that:

- The use of a DC motor with forward curved impellers (centrifugal) makes it possible to regulate on constant flow or constant pressure without sensor. Centrifugal fans have curves with a strong variance in current and speed; if these values are known its is possible to calculate the working-point. With the possibility to calculate the working point with current and speed, a microprocessor can easily regulate on flow or pressure. DC-motors need electronics to control the commutation, if electronics are standard it is easy to integrate extra controls.
- Backward curved impellers normally have only small variance in current and speed, not enough to regulate on constant flow/pressure. These wheels have advantages in service: the small number of blades avoid fast pollution and decrease in fan power.
- Radial fans have efficiency around 60 %, depending on the angle of blades and impeller
- Axial fans have efficiency around 75 %.

3a.3b Low pressure-drop components, e.g. large ducts, supply/exhaust vents:

- Fans with low pressure drop when not operating
- Lower pressure drop heat exchangers, means slower velocity, better heat recovery efficiency
 - duct-in-duct heat exchangers ?
- Filtration
 - is filtration necessary ? what about filtering only in winter ?
 - what do building regulations say about this ?
 - low pressure Electrostatic filters
 - traditional types: what are drawbacks of these, ozone, self cleaning or washing, durability, market response, cost
 - "Flimmer® filters" (www.freshman.se), no ozone generation
 - other new types of electrostatic filter
- Low pressure drop ductwork:
 - what typical system pressure drops are there in the different ventilation systems in different countries
 - shorter wider ducts
 - eliminate ducts altogether ?
 - What is standard duct installation practice is there in different countries?
 - Good ductwork design rules of thumb for low pressure drop

- What ductwork design software is there?
- Sources of ductwork pressure-loss coefficients
- Info on low pressure drop air terminal devices (ATDs)
 - displacement ventilation ATDs

General

In Holland the pressure drop of a typical ventilation exhaust system is about 80-100 Pa at a flow rate of about 40 –50 dm³/s.

The distribution of the pressure loss :

- ATD's (valves) 20-50 Pa
- Ductwork 30-60 Pa
- Roofoulet or Cowl 2-5 Pa

In the Tipvent project [3] we have reduced these values to:

- ATD's (valves) 5-15 Pa
- Ductwork 5-15 Pa
- Roofoulet or Cowl 1-2 Pa

In the Rehyvent project [3] we have targets as low as:

- ATD's (valves) 1-5 Pa
- Ductwork 2-5 Pa
- Roofoulet or Cowl < 1 Pa

These last values can be reached easily with existing knowledge, resulting in a fanpower less than 2 W.

As simple design rules to achieve these values the following velocities can be used as guiding material: duct velocities and velocities in the smallest opening of the ATD (valve) and or roofoutlet in the range of 1 –2 m/s.

It is obvious that this require an optimum duct design and construction. Rectangular ducting in concrete floors (40 X 160 mm) should be avoided. Hence the consequence of it is that the flowrate variation over time due to fluctuations of wind pressure etcetera is bigger than with the existing systems. But who cares ? From the point of view of the occupant of the building as well as hygienic reasons this is not a problem.

Information of ductwork and fitting resistances can be found in [5]

A simplified design tools is available on the Tipvent CD [4]

Fans with low pressure drop when not operating

Since depression level in traditional natural ventilation is very low (a few Pascals), energy required for an assistance fan can be also very low.

AERECO as developed a fan that ensures satisfying airflows all the year by using only 2 Watts per dwelling.

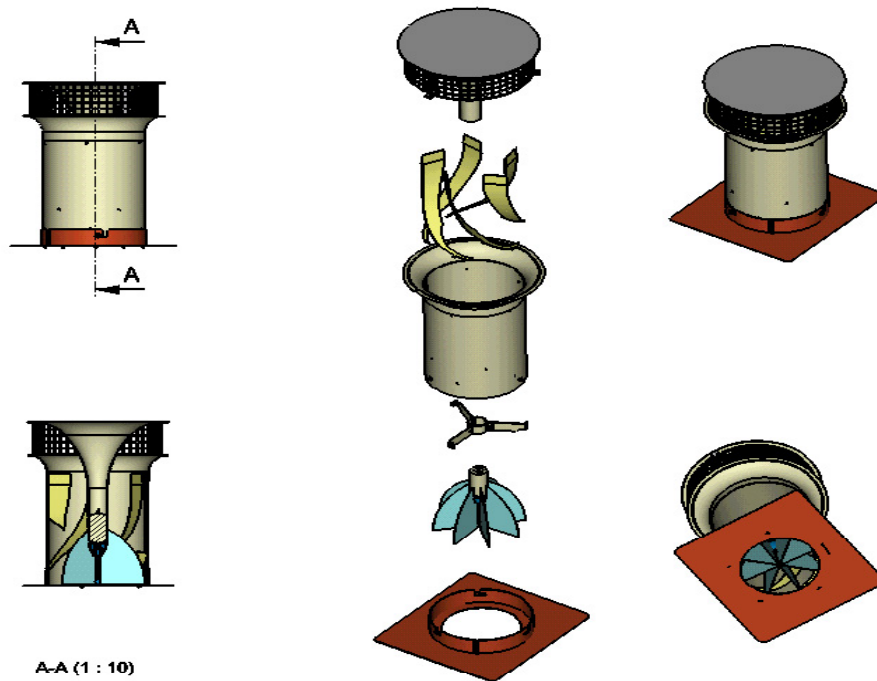

Figure 17 AERECO assistance fan

One issue is that, in cold period, natural ventilation works generally very well. Consequently, no assistance is necessary, and the energy running the fan can be saved. Moreover, stopping the assistance fan prevents from over-ventilation (which can lead to heating energy expenditure).

This is why, in spite of the low energy of the fan, there is an interest to stop it when it is not necessary. The problem is that the pressure drop across an usual fan that is not running is generally very high. Therefore, when natural forces are exclusively used, an usual fan decreases very much the performances of the ventilation system.

In that case, air renewal can be very low, and unexpected pollutants can even be transmitted from one room to another, or from one flat to another.

To limit the pressure loss of the fan (when off), one idea is to design propeller blades with no air resistance when not running. As shown on the figure above, the blades of the propeller (blue part) are parallel to the expected airflow. So, when running, the propeller only provides rotating energy to air, and internal guides placed against the cylindrical parts of the fan orientate air in a longitudinal way. These guides induce no air resistance, since they are sheltered by a diameter reduction upstream, and they become parallel to the flow downstream.

Measurements according to French regulation provide a pressure loss coefficient around 0.9, which means that this fan has 10% less pressure loss than a simple circular duct of the same diameter.

Filtration

No filter at all ?

Filtration of supply air without supply fan systems has to be of very low pressure-drop design. Even buildings with high tightness ($< 0.8 \text{ l/s}\cdot\text{m}^2$ at 50 Pa) will take a considerable part of fresh air throw leakage and thus not filtered air. Filtering systems that rise the underpressure in the building from example 3 to 6 Pa will consequently rise the leakage and the unfiltered part to a higher level. Changing from low class filter (EU3) to a higher class filter (EU7 of conventional type) might even end up in will then higher the unfiltered leakage part and result in a less clean air. (analyse results from IC1)

Low pressure drop filters

There are some filters available on the market which can be used in inlets. On the next page you can see the performance of these filters.

There is only one pro and that is the small amount of filtering itself. There are however different cons.

As low the pressure drop is, it is still a pressure drop. If you define a low-pressure hybrid ventilation-system with inlets defined at 1 Pascal, each resistance is a disadvantage. Maintenance is also a disadvantage. To guarantee a good IAQ regular maintenance of filters is a must. In my experience this gets not easily enough attention of occupants. If maintenance is not done properly there is a real risk that the filter has a opposite effect on IAQ than what should be expected.

Also should be taken into account that the filtering itself in percentage should not be over-estimated (see next page) and that outdoor air-quality in almost every situation is better then the IAQ and therefore very useful to ventilate, even without filtering. Therefore you should think twice to introduce electrostatic filters into your inlets.

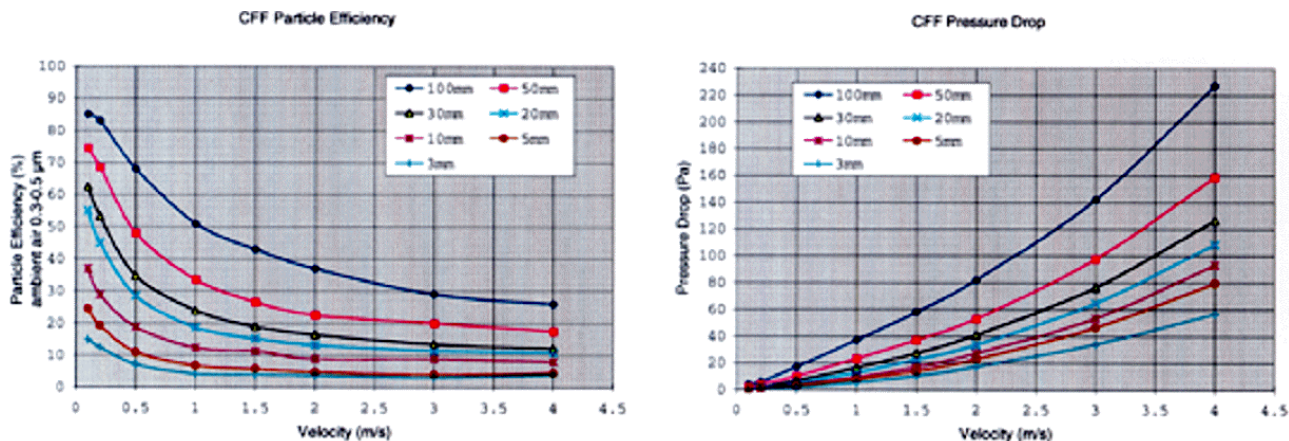

Figure 18 Typical efficiency characteristics, High Airflow Filtration media



Figure 19 Self-supporting, extremely low pressure drop air filter, constructed like 'small bows'

Electrostatic filters

Concerning electrostatic filters, these are presently not common in domestic ventilation systems. We only know that these filters normally are used in air treatment units for larger air volumes. Venmar Ventilation Inc. have an electrostatic filter, with integral filter mats that are replaced up to 3 times a year.

Low pressure drop ductwork

Sweden typical new built exhausts flow systems: 150 Pa. Best practise: 70 Pa.

Good ductwork design parameter: velocity/sound reduction

As soon as a ventilation system is connected to more than a room, there is a need for a distribution system, a ductwork, to connect the different rooms to an fan.

The airflow that is decided suitable for ventilation and thermal comfort reasons has to be transported from the rooms.

The air distribution to and from the rooms, the supply and extract air flows, has to be adjusted to the correct values by achieving correct pressure drops through the pressure resistance in ducts, and ductwork components.

In a ductwork system, pressure can be viewed as energy created by the fan that can be reversibly converted into kinetic energy (airflow), or irreversibly dissipated by wall friction or turbulence effect (in a bend or sudden expansion)

These losses commonly called pressure drop or flow resistance, must be overcome by the fan to meet the desired flow rates at the air terminal devices.

Pressure drops are expensive in that they are directly linked to the fan energy use.

Therefore, the designer should perform pressure drop calculations and should try to minimise unnecessary flow resistance.

Cascade flow principle (ref in this report) can be exploited to minimise the duct run lengths. For example in the Netherlands, in balanced ventilation of 2-storey family houses, the ventilation industry has found out that they can avoid having supply ducts down to the ground floor, if the living room is open plan with the kitchen. There is supply to the bedrooms (top floor) and a supply diffuser in the landing in the top floor. The supply diffuser on the top floor is manually adjustable, so that occupants can close it to force all the air into the bedrooms.



Figure 20 Duct and duct components

A duct system layout has a major influence on;

- Pressure drop of the system,
- On the fan energy, needed to transport the air through the ductwork.
- Also duct leakage can be a severe source of energy loss. (the fan has to work harder)

Another influence on pressure drop in ductwork is the way the ductwork is installed by the installer. The duct leakage is an important issue, the way the duct connections are sealed. They must be airtight.



Figure 21 An example of a poor quality installation

To minimize pressure losses, the flow shall be as smooth and even as possible:

- Avoid abrupt area changes, sharp bends.
- Avoid duct components closer than 5 duct diameters from each other.
- Avoid abrupt area changes in a fan outlet connection to the duct. (this is the most important place to have smooth flow conditions, as pressure losses can be large.
- Avoid flexible ducts.
- Avoid air leakage in the ductwork (Class C airtightness or higher)

AERECO duct system

The "Square Ductwork Range – T2a" has been specially designed for very low pressure drop, as well for natural than for mechanical ventilation.

This 160 x 160 mm square section duct is also a framing very easy to install. All the elements – adaptable to all geometrical situations – have been optimised for very low pressure loss generation (for instance, elbows have air guides inside to limit resistance to air). Moreover, maintenance can be very easily done by removing the facade cap.



Figure 22 T2a Very Low Pressure Drop duct

source references/recommended reading

- **Airways**, Source book for efficient air duct systems in Europe (project 4.1031/Z/99-158) See also annex is this rapport for recommended reading.
- **TIPVENT** source book.
- **Ductwork for air distribution**, It is time for tightness class C. A rapport of DUCT project (1999) Save Duct, from European Commission, Directorate General XVII for Energy. (86/737/EC, OJ No L 335/24 12 96 p.50)

Low pressure-drop air terminal devices

Example: Alusta inlet

A self-regulating inlet is a means of ventilation that keeps the capacity given by the manufacturer at 1 Pascal pressure difference constant, irrespective of the actual pressure difference

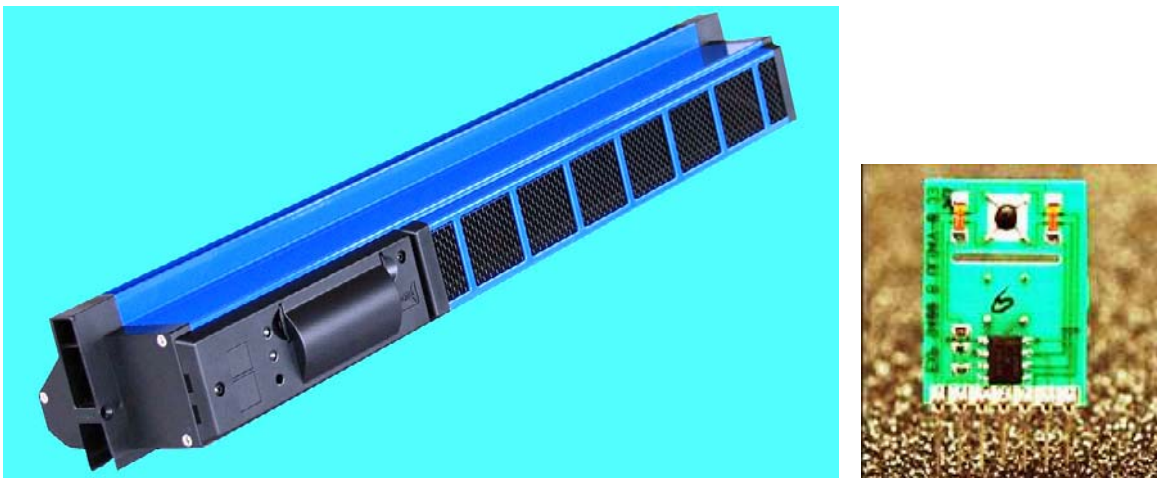

Figure 23 Self-regulating fresh air inlet, with small pressure sensor IC [Alusta]

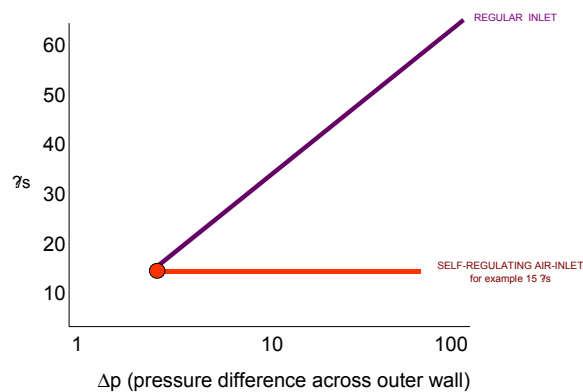

Figure 24 Comparison of flow characteristic of normal and self-regulating fresh air inlets

The air speed and its direction are recorded independently in every inlet by a sensor. The electronics and servo connected to the sensor control the closing mechanism and close the inlet further and further as the pressure difference increases.

When desired the option can be used of closing the inlet when the air flows out from the inside. This is to prevent cross-transport

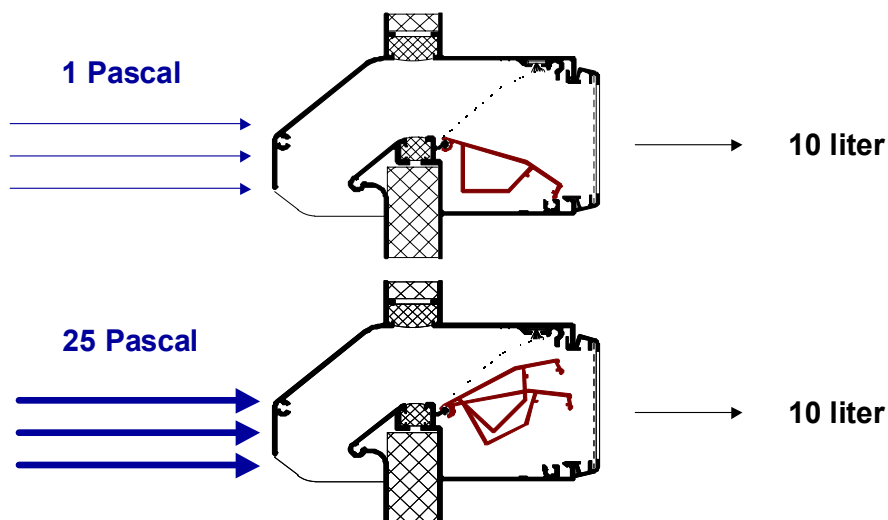

Figure 25 Comparison of flow characteristic of normal and self-regulating fresh air inlets

Technical specifications:

- Ventilation-capacities up to 30 dm³/s/m¹ at 1 Pascal pressure-difference.
- Noise reduction up to 48 dB(A) normalised at 10 m² reference surface.

Example: Venticonvector

The Venticonvector was invented by Wetterstad 1987. It was a consequence of all the draft problems from window- and radiator supply air vents under winter, storm and back-flow conditions. Some similar ordinary devices were produced 20 years earlier but the companies got too many problems with freezing damages so they withdraw. Also wants for larger airflows especially in existing school rooms increased the need of the venticonvector. Three companies have produced similar products during the years. Now the marketing has been expanded to other countries. "Thermopanel" is a trade mark not to be used any more. Now the object, supply air heat convector, is manufactured by A/S Ribe Jernindustri, Ribe, DK and marketed in Sweden by Exhausto AB in Mariestad. There are two sizes of convectors so far, "Exhausto Comfort 100 and Exhausto Comfort 35. In DK, DE and GB, it is called RIO Comfort. The Comfort 35 will be used in the Reshyvent project and the object will be called "Venticonvector" instead of "Supply air convector".

The venticonvector system avoids supply air systems utilizing noisy supply air fans, dirty ducts and terminal vents. It also removes a complicated heat exchanger system of regenerative, recuperative, coupled batteries, heat pipe or heat pump character. All of them are common in Sweden. They are expensive and often give a lot of service problems. Due to the personal demand on everybody to save energy the future ventilation systems will probably be air demand controlled and does not need a heat recovery system in the accustomed way. That fits the venticonvector system very well together with future tighter buildings.

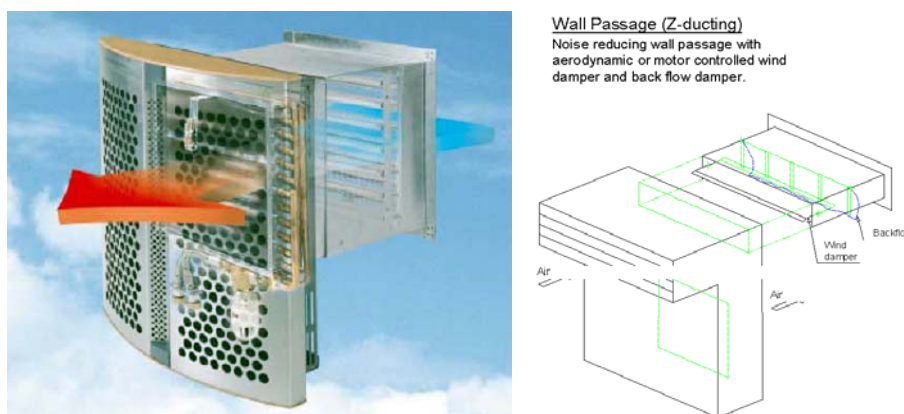

Figure 26 Venticonvector. **Left:** room component, **Right:** wall duct with flow control

Lower pressure drop heat exchangers

The venticonvector has to be designed for the very small pressure drop over the façade as is in hybrid ventilation systems. The size and power of the battery (coil) "Comfort 35" is big enough for the Swedish Reshyvent climate.

The single circuit coil has not more than 2 rows of copper tubing with suitable fin thickness and spacing to keep the pressure drop low on the air side. The one circuit pressure drop on the water side is tolerable. The larger "Comfort 100" has a 2 circuit coil to fit the pressure needs of the pump and thermostatic valve. Normally the circulation pump in resident buildings of Sweden allows a pressure drop of max 0,25 bar over valve and radiator. The most characteristic of the coil is the ThermoGuard system, avoiding freezing brake down at electric power failure. It is a patent of the Swedish firm Aircoil.

The wall passage for the venticonvector of a future design must be superior to the standard venticonvector with respect of noise suppression and rain sheltering. The intake is positioned just beneath the window. It has a wind damper and a backflow damper in the wall passage (Z-ducting), only one blade each. The wind damper can be either aerodynamically or motor/alternatively hand controlled. The wind damper consists of a steel blade, balancing in the air stream. The back-flow damper is only aerodynamically controlled and consists of a hanging plastic film and abutments.

Filtration

Most of the pressure drop comes from the filter. An EU7- filter, of folded type, is a new Swedish innovation of Ralf Andersson, Provenco in Helsingborg. This Allergen filter has very low pressure drop and a high efficiency during the whole life time.

Filters come more and more in window vents and radiator supply air vents. There are different opinions if filtering should be used or not. It is o k, however, to ventilate through window-openings having no filters so venticonvectors only need a coarse filter to keep the insects out.

The wall passage and battery must be easily reached with a vacuum cleaner. If filtering is chosen e.g. EU7, the filter is placed in the perforated cabinet. It can be serviced by the tenant himself, like a filter of a kitchen fan unit. Depending of the outside air dirt, just once or twice a year will do. The Reshyvent project is supposed to have no filters.

Low pressure drop ductwork

So far the normal venticonvector has been sold with straight passage plus a façade cover to suppress noise. That makes it easier to mount in existing buildings.

The full venticonvector is designed to have big flow areas and minimum resistance. The bluff bends in the wall passage have been necessary to suppress traffic noise etc.

The pressure drop of the venticonvector with wall passage, as a function of flow rate, has been measured in the laboratory. Some of the internal pressure drops have been calculated or estimated. Very small pressure, 1 á 2 Pa, is difficult to measure.

The pressure drop over the wall is estimated to be between 0 and 15 Pa due to the exhaust air fan. If there is wind suction on the façade, nil or negative pressure drop can appear. Then the back-flow damper shuts the passage, thus saving energy. In the mode where natural forces are working, the wind and exhaust-fan in co-operation can give pressure drop as high as 50 Pa. Then the wind damper operates and partly shuts off the passage abruptly at ca 20 Pa, so the airflow can keep up with the battery power.

Info on low pressure drop air terminal devices (ATDs)

The cabinet is working as a displacement ventilation device. It is mostly positioned close to the floor just leaving space for the water tubes. The exhaust terminal devices are mostly situated on the opposite side close to the ceiling thus giving good ventilation efficiency.

The cabinet will give a suitable plume, i.e. expanding the fresh air into the room and avoiding draft in the residence zone. The best function will be with a high quality filter together with an extra bit of filter or block in front of the battery. That broadens the plume.

Wall passage

The wall passage for the venticonvector is designed and tested by Wetterstad Consulting AB in Löddeköpinge, SE (WCAB) for the Reshyvent project. It is superior to the standard venticonvector with respect of noise suppression and rain sheltering. It has a wind damper and

a back-flow damper in the wall passage (Z-ducting), only one blade each, see diagram, encl.1. The wind damper can be either aerodynamically or motor/hand controlled. The wind damper consists of a steel blade, balancing in the air stream. The back-flow damper is only aerodynamically controlled and consists of a hanging plastic film and abutments.

Service

The wall passage and battery must be easy to reach with a vacuum cleaner. If filtering is chosen the filter is placed in the perforated cabinet of Danish design, see photo from the test rig, encl. 2. It can be serviced by the tenant himself in the same way he does with a filter of a kitchen fan unit. Depending of the outside air dirt, just one or twice a year will do. The cabinet is working as a displacement ventilation device. The Reshyvent project is supposed having no filters.

Battery

The heat exchanger battery (coil) is sold by Aircoil AB in Årjäng, SE and manufactured by Sierra, Verona, IT. The size and power is big enough for the Swedish climate. The single circuit coil has not more than 2 rows of copper tubing with suitable fin thickness and spacing to keep the pressure drop low on the air side. The larger Comfort 100 has a 2-circuit coil to fit the pressure needs of the pump and thermostatic valve. Normally the circulation pump in resident buildings allows max 0,25 bar pressure drop over valve and radiator to avoid stream noise. The most characteristic of the coil is the ThermoGuard system, avoiding freezing brake down at electric power failure.

Venticonvector pressure losses.

The full venticonvector is designed with big flow areas and minimum resistance. The bluff bends in the wall passage have been necessary to suppress traffic noise etc. Most of the pressure drop is in the filter. EU7 synthetic fibre, EU2 or no filter can be chosen. The EU7-filter, of folded type, is a new Swedish innovation of Ralf Andersson, Provenco in Helsingborg. This allergen filter has very small pressure drop and a high efficiency during the whole life time. However, our Reshyvent project has desired to avoid the use no filters.

The pressure drops of the venticonvector at all flow rates have been measured in the lab. Some of the internal pressure drops have been calculated or estimated. Very small pressure of 1~2 Pa is difficult to measure. Following values have been collected from the curves at 15 l/s.

The pressure drop over the wall is estimated to be between 0 and 15 Pa due to the exhaust air fan. If there is wind suction on the façade, nil or negative pressure drop can appear. Then the back-flow damper shuts the passage, thus saving energy. In the mode where natural forces are working, the wind and exhaust-fan in co-operation can give pressure drop as high as 50 Pa. Then the wind damper operates and partly shuts off the passage abruptly at ca 20 Pa, so the airflow keeps up with the battery power.

Table 15 Venticonvector pressure drops at 15 l/s (living room)

	No filter	EU7 filter
Wall grid (facade)	2	2
Wind damper	1	1
Back-flow damper	0	0
Battery	2	2
Filter	0	5
Cabinet (room inlet)	1	1
Total	5~6 Pa	11 Pa

Benefits of the ventilation system.

The venticonvector system of the Reshyvent avoids a supply air system utilising noisy supply fan, dirty ducts and supply vents. It also removes a complicated heat exchanger system of regenerative, recuperative, coupled batteries, heat pipe or heat pump character. All of them are common in Sweden. They are expensive and often give a lot of service problems. The Reshyvent system is air demand controlled and does not need a heat recovery system in the accustomed way.

Controls

The control system of the venticonvector is normally very simple in big localities such as classrooms. In the Reshyvent project, however, with high demand of accuracy, it will be somewhat complicated. There is small pressure drop at hand.

Air side

In Nordic countries the houses are tighter than in the others. In our Reshyvent project we say half of the supply air comes through the vents and half through the cracks of the building. Due to that it is possible to control the hybrid ventilation in the Reshyvent not only on the exhaust airside but also in the supply air vents.

In our hybrid ventilation where the exhaust fan is working together with natural forces, the fan has a constant flow control. It regulates between 40 l/s (max, forced airflow) and 8 l/s (min, no one at home) in a reference apartment. The flow rate also depends of the number of people in the flat.

At night the flow rate regulator has to decrease the flow to 17 l/s in the apartment. Then the sleeping rooms need the whole flow and the living room needs only air from the supply air vent of the radiator and nothing from the venticonvector. Therefor the venticonvector has a built in mechanism and motor working on the wind damper blade to shut off the air. This function is manoeuvred by the control system of the apartment.

Water side

Normally a radiator thermostat and valve is built in into the venticonvector entrance tube. The supply air temperature, +8 to +23°C is set by hand. The best adjustment point has shown to be 18 °C in school localities.

Such a radiator thermostat is a slow working device. It controls the water into the radiator according to the room temperature. The venticonvector on the other hand has a separate sensor downstream the battery that controls the supply air temperature.

We want to develop a new control system for the venticonvector that holds the room temperature constant at a desirable temperature and also controls the supply air temperature to a minimum of 18°C.

3a.3c can supply or exhaust fan be eliminated altogether, i.e. only exhaust fan needed ?

3a.4 Efficient controls - What is the state-of-the art and trends in controls?:

3a.4a Control strategies

- i.e. state-of-the-art in "home automation"/"smart house"/domitica systems
 - e.g. electrical load switching,
- What techniques are available for controls of hybvent systems ?
- How can hybrid ventilation systems be implemented in home automation ?
 - What about costs of these systems ?
- Heat recovery control: e.g. automatic bypass in summer, efficient frost protection strategies in winter
- How to use Adaptive control strategies to make best use of dynamic effects of control
 - e.g. adaptive modelling CO2 sensing
 - e.g. self-learning optimal night ventilation, or allow building to overheat slightly during daytime to reduce night time heating
- Inlet control based on building model, online building response modelling (building emulation)

Extending building automation systems to ventilation

Building automation has been extensively used for heating and air conditioning systems. There is currently a trend to increase automation of ventilation systems. The automation process is

enhanced by merging technologies of temperature and ventilation controls in the BAS. In fact current BAS offer on-line information of different characteristics of the building that is required by the heating and /or air-conditioning system. Such information includes temperature in different zones, humidity level in ducts, pressure sensors, presence sensors...

Integration of control of ventilation system in the BAS will promote sharing of equipment such as sensors (pressure sensor, presence/motion sensor...) or in some cases sharing of drives. Besides some sensors that are typically required by ventilation control systems (CO2 sensors, humidity sensor...) might be useful for the air conditioning system to ensure better indoor air quality and comfort of the occupants. In general, communication between ventilation system and other technical systems will increase the possibility for optimum use of the different systems to improve 1) people’s comfort 2) reduce energy consumption. Furthermore the fact that there is sharing of equipment (sensors, drives, communication cables...), and the possibilities to supervise the whole systems simultaneously, will lead to reduce maintenance cost by careful monitoring of all equipment.

The effort of bringing more communication between equipment or systems has also promoted decentralisation of intelligence to the field level. Terminal control units or sensor are now smart and are quite autonomous. This reduces the amount of information to be transmitted on the network and makes the overall system more robust. In ventilation systems, this type of decentralised intelligences has been used for a very long time for example in humidity-controlled systems where the extraction grilles had modulated flow rates with respect to humidity concentration in kitchen or toilets. These systems were stand alone and could not provide any information to other equipment such as the heating systems. Nowadays products are available with increased intelligence thanks to the development and reduced cost of micro-chips. Electronic air inlets (for example from Alusta) or intelligent sensors (for example from SenseAir) allow for a certain amount of decision-taking capabilities locally and reduce the number of communication data with higher control levels.

It is expected that the development of BAS in residential building will necessarily include such intelligent field level devices.

- o O o -

The hybvent system needs a complementing control system that connects the sensors, actuators and manual settings. The costs will depend a lot on volume. Radio-signal systems might be the very cheap in future technology and avoid the need for cabling work, but demand very big sales numbers.

Example: AERECO humidity & presence detectors

Humidity and presence controls are two systems largely spread in France for many years. Indeed, regulations now encourage such modulating systems, ensuring both good indoor air quality and energy savings.

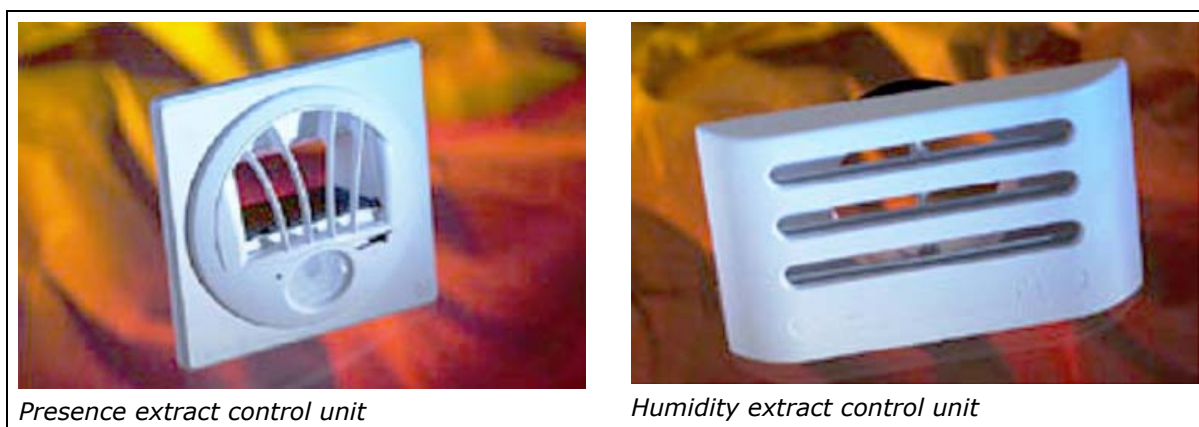

Figure 27 Presence-detector and RH-detector extract ontrol units [AERECO SA]

3a.4b Sensor technology

- What DCV kinds of sensors are presently available ?

- CO2
 - presence detection, both on/off and continuous types
 - RH
 - Mixed Gas (TVOC)
 - thermostats, "artificial skin sensors"
 - connect to fire alarm system ?
 - Simple manual controls: Standard programmable timer, Simple on/off switch near front door, Connection to light switch
- what is the expected price reduction in relation to mass production ?

Present available kinds of sensors for DCV

Due to human activity the indoor air is polluted with several contaminants. The level of the contaminants can be directly related to the activity level and therefor can be used as a measure for the amount of required ventilation. Ventilation based on Indoor Air Quality (IAQ) is referred to as Demand Controlled Ventilation (DCV).

In table 1 a survey is given of sensor types that are sensitive to deferent kinds of contaminants.

Table 16 Sensors for IAQ related to human activity

		CO ₂	RH	Mixed gas (VOC)	CO	SO ₂	Presence detection	Simple timer and manual controls
Air pollution and human activity	Human exhalation	●	●				●	●
	Bathing, washing		●				●	●
	Cooking		●	●			●	●
	Body odour			●			●	●
	Smoking / fire	●		●	●		●	●
	Peeling fruit, plants			●			●	●
	Paint(ing), cleaning substances, solvents			●			●	●
Combustion		●		●	●			
Emitting sources	Building materials			●				
	Furniture			●				

CO₂ sensors

The CO₂ concentration seems to be a good indicator for IAQ in buildings where human activity is the main pollution source. It is commonly agreed upon that the CO₂-concentration has a good correlation to the respiration of humans and their production of body odour. However, there is still no common agreement upon the relation between the desired IAQ and the corresponding level of CO₂-concentration. In fact these values have to be considered in terms of a dose-effect relation. This means that not only the occurring CO₂-concentration itself but also the exposure time should be taken into consideration. Maximum acceptable comfort level ranges that are commonly agreed upon range from mean values between 1200-2000 ppm. The outdoor level is about 350-450 ppm and the MAC-level for humans is 5000 ppm.

Because CO₂ is an inert gas, conventional physical or chemical interactive technology cannot be used to detect CO₂-gas. Today most of the commercially available CO₂-sensors utilise some form of infrared(IR) -based detection. The detection principle uses the physical property that different inert gases absorb specific and unique wavelengths in the infrared spectrum.

A different measuring principle is based on semi-conductor-technology. The sensor's electromotive force (emf) shows a linear relationship with the logarithm of CO₂-concentration. At this time the lifetime of the sensors is limited to about 2 years.

The manufacturing of the sensors takes place in batches. The demand and the use of sensors in ordinary ventilation systems is not common so the batches are small which results in high costs per piece.

The challenge the building and sensor-industry are facing is the development of mass production of accurate CO₂-sensors at low costs. There is a large number of suppliers (>20) of CO₂ sensors who have sensors that fulfil the technical requirements from table 1 for measuring IAQ in hybrid ventilation systems.

Table 17 Specifications of most CO₂-sensors for IAQ that are commercially available.

Measuring characteristics	
Measuring range	300-2000 ppm
Accuracy	± 50-100 ppm
Sensitivity	< 30 ppm
Cross sensitivity	Low; 5-95% RH, 10-40 °C
Reproducibility and hysteresis	< 10 ppm, little hysteresis
Rise time	< 1 min
Stability	good
Output signal	0-10 V or 0-4 mA or 4-20 mA
Connection to the control system	LON-like, Wireless or bluetooth-like
Power consumption	< 3 W
Installation, operation and maintenance characteristics	
Price range	€ 300-500
Mounting	Wall or free in space
Size and weight	100*100*30 mm ³ , < 0.250 kg
Maintenance	> 10 years
Calibration interval	Daily, > 5 yr, > 15 yr ore none
Power supply	230V or 24 V
Operation conditions	immunity to climatic (dust, humidity) mechanical and electromagnetic interference

Presence detection

Presence detection makes use of passive infra red technique (PIR). There is a distinction between continuous measuring and on/off types. In price and application both do not differ much. The air-flow is determined in a indirect way. In fact a PIR sensor is functioning equal t a on/off switch without intermediate stages. Therefor the ventilation rate can be too high or to low. Especially in rooms with a low variation in occupancy such as small cellular rooms and classrooms PIR sensors can be successfully applied

Because of the broad use and application in security installations the PIR sensor is already a mass-product that is even available for consumers at the local shops

Relative humidity (RH) sensors

In an environment where moisture production is dominant (bathroom, kitchen) humidity sensors can be used to control the IAQ. The use of a certain way of DCV leads also to a different humidity balance in dwellings. Lower ventilation rates have less potential of exhausting moisture to outside. Mainly in ventilation-concepts based on ventilation per room the rooms where moisture production is dominant (bathrooms, kitchen) RH-controlled ventilation is wanted.

Example : AERECO RH actuator technology

AERECO system combines both extract grilles and air inlets. Air inlets allow to control individually humidity in the "dry" rooms (bedrooms, living room, etc...) whereas extract grilles are settled in the "wet" rooms (bathroom, kitchen, etc...).

The principle of these devices consists in a mechanical humidity sensor made of several nylon bands – lengthening according to relative humidity level – operating shutter(s) which control(s) area opening. Thus, higher humidity level is detected in a room, more the area will be opened, and so more the room will be ventilated. No external energy source is required so that these autonomous devices can work perfectly for many years (accurate PDF documentation are available at <http://www.aereco.com>).

Consequently, significant air renewals are ensured when needed – humidity is representative of moisture pollution, but also of human activity, and thus linked to metabolic CO₂ emission – and heating energy is saved the other times (gain around 30% relatively to a usual basic French ventilation installation).

Though each device operates individually, the whole installation works like a real system. Especially in natural ventilation, for a several floor building collectively connected, limited airflows at some floors allow higher ventilation potential for the others. Such a modulating system leads to a significant homogenisation of the airflows in natural ventilation.

Such devices also exist for mechanical ventilation. Some versions combine humidity control with presence detection (for offices, toilet, etc...) or direct people control.

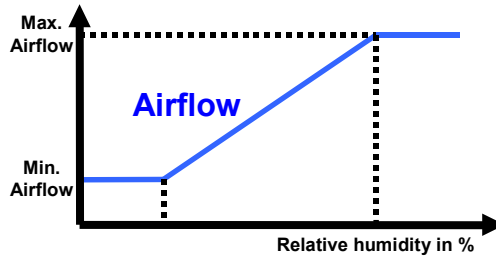
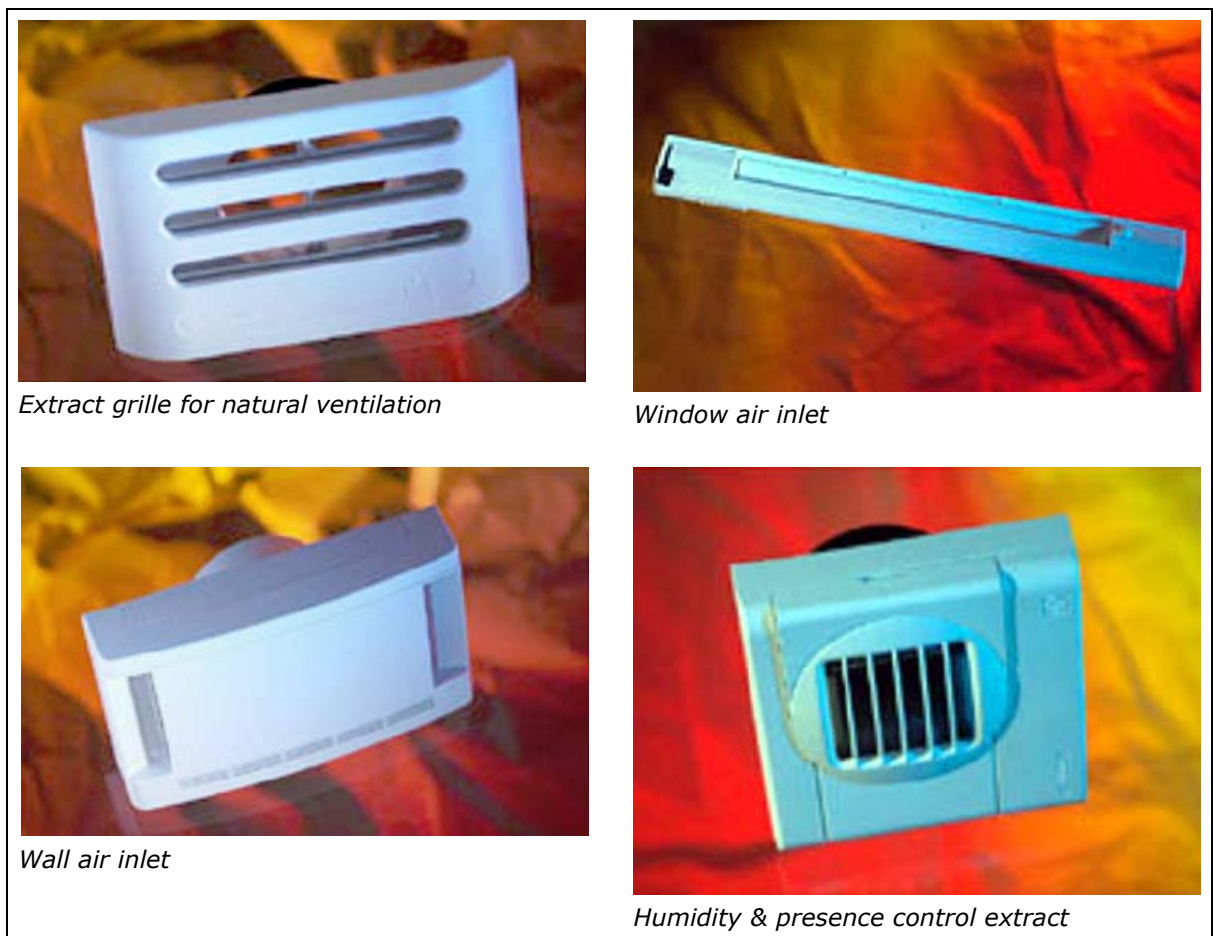

Figure 28 Flow control characteristic for AERECO RH-controlled devices



Extract grille for natural ventilation

Window air inlet

Wall air inlet

Humidity & presence control extract

Figure 29 Examples of AERECO air flow devices

Example: Humidity controlled ventilation in French residential buildings

<http://www.aereco.com>

<http://www.aldes.com>

<http://www.anjos-ventilation.com>

<http://www.atlantic-ventilation.com>

Humidity controlled ventilation is used in French residential buildings since the beginning of the eighties ; these systems are used both in new residential buildings (always mechanical systems) and in retrofitted buildings (mechanical systems or passive stack systems).

The opening of the components (outlet and sometimes inlet) is in accordance with the indoor relative humidity.

The cost of these systems (including implementing in the building) is about 500 to 700 €

Mixed gas (VOC) sensors

Theoretically is measuring IAQ according to the VOC-concentration can be very successful mainly because the sensors are low-cost. However, there are several barriers that are still hinder broad application.

Mixed gas sensors are sensitive to a large number of volatile organic compounds (VOC). VOC's are related to the emission of body odour, but also for the emission from other sources such as building materials (e.g. glue, paint), furniture and cleaning substances. The cross sensitivity for humidity requires automatic calibration on a daily basis. This can be done with a sample of outdoor air in the morning. At high concentrations of mixed gases saturation of the sensors occur.

Above all, unique and workable relationship between the IAQ and the presence of VOC such as for CO₂ is commonly agreed upon has not been established yet. At the same time the acceptable level of mixed gases vary with the type of chemical substance. Namely, VOC sensors differ in sensitivity to different gases, and are therefor hard to calibrate to a known measure of contaminant concentration and comparable IAQ.

It can be concluded that where human activity is the main pollution source CO₂ concentration is a better parameter for IAQ then VOC. Table 3 gives an comparison between de characteristics of mixed-gas and CO₂ sensors.

Table 18 Comparison between mixed-gas and CO₂ sensors

Aspect	Mixed gas	CO ₂
Gases measured	Wide range, non specific	Carbon dioxide
Measurement units	Not referenced to know measure	ppm
Resulution	1 unit (not quatified)	20 ppm
Interference	Temperature, humidity, also silicon vapors and hydrocarbon species	None
Calibration	Cannot be calibrated	Two calibration points
Technology	Interactive, sensor chemically reacts with pollutants, degration of sensitivty	Non-interactive, sensor not in contact with sampled air
Drift	Constant and unpredictable	<30-100 ppm per year
Best application	Measure changes in IAQ, industrial application	Ventilation control for occupancy

Connection of IAQ sensors and the fire alarm system

In case of a fire the CO₂ concentration increases rapidly above the 5000 ppm. For IAQ a typical range is 800-2000 ppm. Most IAQ sensors have this range and are not suitable for fire detection. In the meantime are sensors for fire detection not accurate enough to control ventilation rates. When under ventilation occurs the CO₂ concentration easily can rise above 2000 ppm although switching on the fire-alarm is not needed

Simple timer and manual controls

In the category simple timer and manual controls can be distinguished:

- Programmable timer control
- Adaptive timer control
- Connection to light switch
- On/off switch near front-door or separate rooms

These timer and manual control have the same disadvantage that the occupant is directly responsible for the control of the ventilation. Especially the connection to a light switch is only possible in rooms where artificial light and ventilation always at the same time are required.

A good match between the user and the control system can be made by a adaptive timer control. The adjustments of the ventilation rates that users make are (partly) adapted by the control system and will be repeated in the next days.

For timer and manual controls the required electronics are basic and can be stated as mass-products.

Artificial skin sensors as thermostat

An optimal indoor climate will be accepted only by 95% of the users according to the theory of Fanger as stated in ISO7730. According to a study done by the Fraunhofer Institute fur Baufysik [] this value is even lower: 85%. It might be the main reason for the often complained low acceptance of HVAC-systems. This problem can only be solved by the possibility to adjust individually the indoor climate.

Multisensor systems

Dallas digital sensors. (Stigberget, IC1) provides cost effective solutions for multi sensor systems integrated with LON (Local Operated Networks) for building system integration (Figure 31).

Background

Physiological background of thermal comfort

“Too cold” is sensed when the skin temperature falls below a certain threshold value. This can be for the body as a whole but also a locally effect e.g. at the neck or at the feet. “Too warm” is sensed centrally in the brain and non directionally. When a certain threshold value in the brain is surpassed and warm-receptors react combined with sweating.

Physical background

Heat transfer by convection and radiation in combination with the physiological effects leads to de development of a artificial skin sensor. This sensor simulates the heat balance of the skin regarding convection and radiation.

At this moment artificial skin sensors are best used in combination with individually cooled/heated ceiling in commercial and industrial buildings. In dwellings cooled and heated ceilings, or even concrete core activation, requires a main change in heating concepts in combination with new ventilation concepts.

The expected price reduction of sensors in relation to mass production

Table 19 Price of sensors for IAQ

Sensor type	Unit cost (€)	Bulk order cost (€)	Batch size	Remarks
CO2	300-500	< 75	> 25.000	See also figure 1
PIR presence detection	50	< 50	> 50	
Relative humidity	50	< 50	> 50	
Mixed gas (VOC)	50	< 50	> 50	
Artificial skin thermostat	Not commercially available yet			
Manual controls	50	< 50	> 50	

In the last decade the price has dropped from € 1.000 in 1990 to € 500 per sensor. At this moment the price range lies between € 300-500,--. With respect to the other components of the ventilation system this is together with the control system the most expensive part.

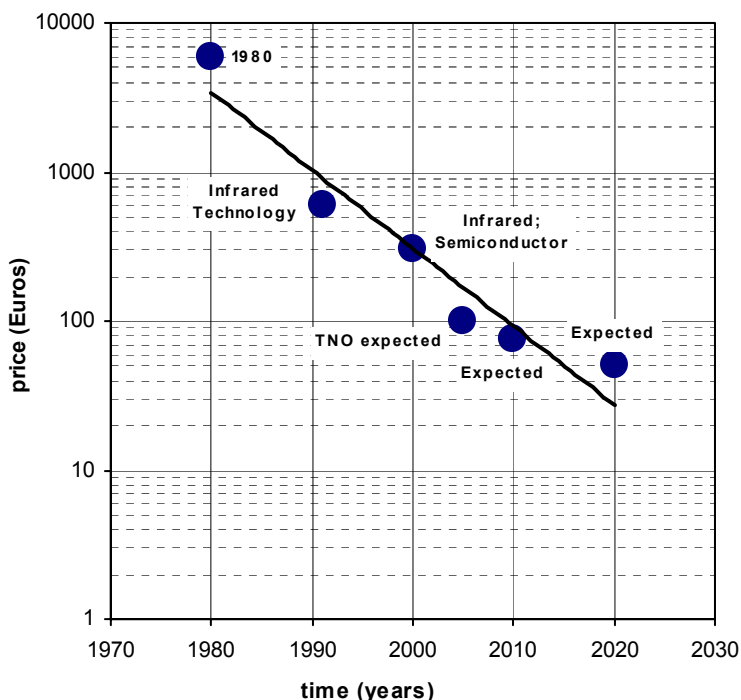

Figure 30 Trend in change cost of CO₂ sensors

3a.4c Actuator technology (dampers, fan controls, etc) ?

- What developments are there in self-adjusting, self regulating fans: State-of-art, pros and cons of flow-adjusting fans, e.g. price
- Other actuators pros/cons reliability

Fan speed control

Self-regulating fans (air flow) communicates with set values (set signal 1-10 Volt) from the control system according to the demand and is then an easy system component that has not to be adjusted. Monitoring the set values indicate the actual air flow and can be logged in the supervision system. (IC1).

AC single-phase motor fans are generally controlled by adjusting AC voltage ; the speed can be reduced at 50 % of the nominal speed. Reducing speed can generate acoustic problems on the other hand the efficiency decrease.

AC three-phase motor fans can be controlled reducing the frequency (be careful to electromagnetic interferences)

DC motor fans are controlled by adjusting AC voltage ; these motors have a wide range of variation.

Other actuators

To be fulfilled with the WP 7 'Control and regulation strategies support unit'

<http://www.systemair.com>

<http://aereco.com>

<http://atlantic-ventilation.com>

<http://acthys-gie.fr>

3a.4d Communications technology

- bus systems appropriate for the domestic market
 - is it most economic to make the ventilation system completely autonomous?

- what benefits can be gained from communication between the ventilation system and the rest of the house ?
- One of the ICs asked for information on wireless sensors and controls. What is available at the market? Cost advantages with respect to wiring ? (WP3)

The evolution of building automation and direct digital control in the 1980's has favoured the development of communication technologies in buildings. Today building automation system offers two main possibilities to integrate the control of different equipment/applications in a building:

- proprietary systems,
- open systems

A proprietary system is a closed system that is developed by a single manufacturer/contractor. The latter holds the knowledge underlying the development of the system. In such systems, the initial costs might be relatively low and easy to set up, but the building owner is locked into products of a single manufacturer and can hardly take advantage of innovative technologies. Any new technology that uses another protocol requires integration by the manufacturer.

An open system is one where in standards are developed, published and maintained by an independent recognised organisation (CEN, ASHRAE/ANSI...). Any change to the system requires the comments of users, industry, professionals before being approved by the standards / organisation. Open communication protocols are now becoming used for the integration of equipment from different manufacturers. This offers the following benefits:

- **Media sharing:** different products from different manufacturers run on the same communications cables,
- **Vendor independance:** it applies for initial purchase of different equipment and / or system extension.

Both system architecture have the following capabilities:

- **Connection of different building applications:** HVAC, lighting, solar protections, fire, access/security...
- **Single supervision:** all services can be viewed from one user interface.

Standardisation of comms protocols

The CEN 247 WG4 has been working on standardisation of data transmission methods between products and systems for HVAC applications. This working group has divided the communication within a building automation system into 3 types of communication requirements:

- **The Management net:** workstation to workstation communication,
- **The automation or control net:** plant controllers and workstations,
- **The field net:** terminal unit controllers, sensor devices, drives...

The work of CEN TC247 is to enhance the implementation of BAS (Building Automation System) by supporting a number of standards. To bring down cost, the standardisation work promotes open systems architecture.

Table 20 A list of communication protocols and the media that are required [Adapted from: BCG group, UK]

Level	Protocol	Transmission Media
Management	BACnet	Ethernet, PSTN / dial up modem
	WorldFIP	Twisted pair
Automation	BACnet	Ethernet, LONtalk, PSTN / dial up modem
	EIB	Ethernet
	PROFIBUS	PROFIBUS FMS - twisted pair
Field	EIB	Twisted pair, Mains signalling
	BATIBUS	Twisted pair
	LONtalk	Twisted pair, Mains signalling, radio...

Some commonly used open standards have not been recognised by TC 247. But will remains in use:

- MODBUS which is often used to attach HVAC plant modules such as a chiller to a BAS.
- IT standards such as Microsoft COM, DCOM or internet standards (TCP/IP, HTTP...) which is used at management level.

Some open communication systems are listed below:

- **BACnet** (<http://www.bacnet.org/>) – The Building Automation and Control network was developed by ASHRAE and is now published as an ASHRAE/ANSI standard and a CEN standard.
- **LonWorks** (<http://www.echelon.com/>) developed by Echelon in the USA. It is a general purpose network using the LonWorks protocol and the « Neuron » chip. It is most suitable for device-level integration and widely used in buildings on twisted pair using a transceiver known as FTT-10.
- **MODBUS** (Jbus) designed by Gould Modicon Company is not an official standard and is supported by most Programmable Logic Controllers (PLC). It relies on a Master/Slave serial protocol.
- **Konnex** (<http://www.konnex.org>) is the result of the merging of 3 communication systems namely BATIBUS, EIB and EHS.
- **PROFIBUS** (<http://www.profibus.com/>) developed by The German Federal Government for Research and Technology together with Siemens. It is mainly used on industrial sites.
- **WorldFIP** (<Http://www.worldfip.org>) developed in France and has achieved the status of a European Standard.

The main issue for the success of integrated solutions in residential buildings is to define the appropriate communication protocol and the media for information transfer. It is most likely that BACnet, Konnex and LonWork will be the major actors in this field.

LON

LON (Local Operated Networks) for building system integration is an open standard and can be used for all kind of building intelligence, as web-cameras, booking of laundry room, monitoring of air flows and temperatures, set values etc. System relative cost will decrease with the number of functions included.

LON with twinned pair cables costs less and is more reliable but ads extra costs for the cabling. LON-systems with signals carried on the electrical grid network are though becoming less costly and more reliable and thus the best choice when installed in existing buildings.

LAN networks to all flats might in the future override the need of a local network, but still the signals has to be identified and addressed in a similar way as LON provides.

The benefits for connecting the individual control system for the flats to a building systems are several:

- Maintenance and controls of temperatures and air flows. When things go wrong you want the information monitored.
- Makes individual metering a part of the DCV – system

- The temperature measuring in the flats might be used for temperature compensation in the central building heating system. (IC1)
- Makes the monitoring and system settings available for WEB-sites. (IC1, Stigberget)

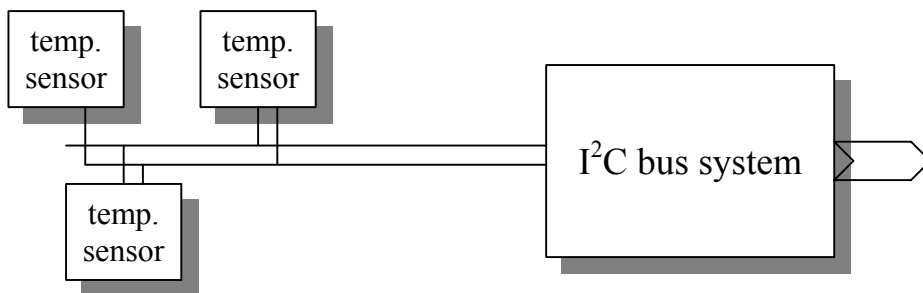

Figure 31 Bus system for an apartment building, with temperature sensors

Communication media in residential buildings

3 main communication medias are used in residential buildings:

- specific wires
- radio
- PLC using existing main network

Radio and PLC are very attractive for use in retrofit of buildings since they avoid the need for new wiring which is otherwise very expensive.

Radio communication

In the European "PHOTOVENT" framework, a wireless communication system between motorised extract grilles / inlets, sensors and a data processing station has been prototyped.

The purpose was to have devices connected without any wire for a very simple installation. Consequently, they had to be supplied by photovoltaic panels (air inlets on windows) or by batteries (indoor sensors).

To transmit information (need measurement from sensors) and to receive information (target opening area for the grilles / inlets), through walls, from one room to another, standard AM 433 MHz radio modules have been chosen

Manufacturing costs for reliable modules has been then evaluated around 20 Euros for a transmitter, 30 Euros for a receiver and 40 Euros for a combined transmitter/receiver. Prices have not significantly decreased, but technology has been improved with more integrated and smaller elements.

The main problem in the Photovent project was the constant energy consumption around 15mA of the receiver module. A strategy had to be elaborated in order to supply the receiving part only when necessary.

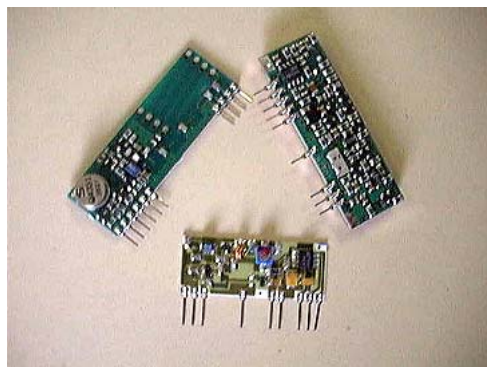

Figure 32 Standard radio transmitter [AERECO SA]

Information from sensors and even grilles and inlets (confirmation of well working) were sent to a data processing station which was able to decode the name (and type, location,...) and the information of each device. Then, after calculations, the processing station was able to transmit to grilles and inlets the suitable configuration to take.

For autonomous devices supplied by non-rechargeable batteries, transmitter/receiver modules are required to limit energy consumption (even for only receiving data, these devices have to "wake up" from time to time, to inform the station they are ready to receive data, and then to switch off transmitting and receiving modules for while).

To be able to use autonomous devices, supplied by non-rechargeable batteries, it was absolutely required to limit the energy consumption of the transmitter/receiver modules.

In the "Photovent" project, a solution with wire connection (to decrease costs) has also been prototyped. To facilitate the installation of the devices, these ones had to be connected between themselves with only 2 wires, in whatever order. The only requirement was to connect "the blue wire on the blue connector and the brown wire on the brown connector".

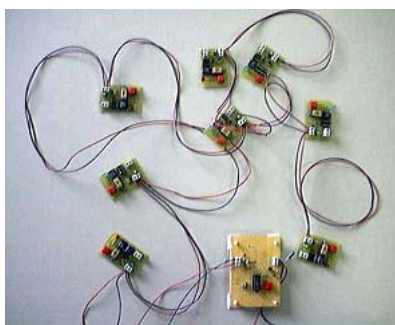

Figure 33 Two-wire communication [AERECO SA]

Energy supplying and data transmission were both ensured through these two wires. A bus type protocol allowed to identify each device and to synchronise data transmission. The manufacturing costs of such a communication system (more reliable since no emitting length limit and low interference) have been evaluated less than 20 Euros, which means less than half the radio costs. On the other way, installation costs are obviously higher.

With spreading domotica nowadays, it may be possible to use already installed devices for ventilation control. For instance, alarm presence detectors could be used for occupancy ventilation strategies. The problem is first, to suit to the output signal type (which may be very different from one system to another), and to be sure that the detection sensibility is compatible with an occupancy detection for ventilation. Moreover, using existing sensors does not seem really interesting since, most of the time, sensors are not the most expensive elements (less than 30 Euros for a presence or a mechanical humidity sensor) but the communication part and the difficulty to adapt all data transmission types.

Today, the most interesting solution seems still to develop ones own wireless devices, by using usual standard radio communication modules existing on the market.

3a.5 Behavioural incitement to energy-efficiency:

- e.g. in multidwelling buildings, individual metering of energy use for heating is in most cases a necessary complement
- reduce the need for window airing in winter (synergetic effect with proper balanced ventilation)
- individual control - maximise potential for adaptability (adaptive thermal comfort)
 - e.g. window airing for summer cooling, controllable shading
- ergonomics : easy to operate the building services
- routines for ensuring homeowners learn to operate building services competently
- should be a conscious effort to initiate things that consume energy
 - e.g. manually switch on lighting, but it switches off automatically e.g. when person leaves room (IR-detector/timer)

- e.g. light switches on same base plate operate in different directions, can't just lazily switch them all on at once

A important point is individual metering in case of central heating and ventilation systems. As soon as individual metering is applied people will be more keen to reduce the use of radiators and fan position of the ventilation system. But what is even more important is the use of windows for airing. Looking to the need for airing one can easily show from hygienic reasons that airing of about 20 minutes is more than sufficient.

During airing the flowrates through a window can be at levels of 50 - 100 dm³/s. So much more than the total flow required for a whole dwelling. Reducing airing in practice is a quite difficult task. An average duration of airing in dwellings is quite normal 3 – 5 hours per day. [6] In the EU study reported by Dubrul some people were confronted with their behaviour in terms of window airing. There was a group who ventilate to less about 1/3 and also about 1/3 where using their ventilation provisions to much. Window airing was used the most in that case. After instructions the effect was measured. Only the first three weeks after instructions a small effect was detected by people who generally were concerned about energy and environment. After three weeks the effect was negligible. Although a lot of energy can be saved by using windows in the right way to motivate people to do so is a hard job. Other studies gives the suggestion that all kind of information such as, TV spots, Advertisement in journals and new papers, clear instructions to homeowners and education in schools on how to use your ventilation system well seems necessary to reach any energy savings along these lines.

In periods where the outside temperature becomes higher than the inside during the day passive cooling over night through airing is an option which should be explored to its maximum because this may avoid mechanical cooling and aircondition systems in dwellings very much.

3b Replacement with renewables

This section deals with how to replace the remaining minimized energy consumption with renewables and/or primary energy with more efficient conversion

After having implemented all possible and feasible energy efficient ventilation principles and controls, according to the trias energetica approach, this section exploits the possibility for implementing renewable energy technology and replacing the remaining minimised energy consumption of a hybrid ventilation system.

3b.1 What necessary support energy is needed ?

After having implemented the appropriate energy-efficient technologies mentioned above, what power is needed for:

- driving Air flow (Fans or natural driving forces)
- other actuators (solenoids)
- sensors
- frost protection power (heat recovery units) is needed in different climates
- heating batteries, to preheat air, i.e. low-temp water battery instead of electric

Info on efficiency of equipment, e.g. fans, heat recovery units, transformers

The possibilities for integration and use of renewable energy in any system require an identification and quantification of the energy consumed by the system. In this case it is relevant to determine the necessary support energy consumed by the different subsystems in a ventilation system i.e. sensors, actuators etc. This is important in order to get an overview of the typical total power needed to run a ventilation system and thereby to illustrate if and which subsystems may be powered autonomously by renewables. However, the consumed energy in a ventilation system very much depends on the individual system and components used. This section therefore only briefly states examples and ranges of power consumed by some of the main subsystems.

The specific power consumption for a system must be identified in each individual case, in order to analyse whether renewables may be used to supply some or all of the necessary support energy.

3b.1a Fans

The energy consumption of fans varies depending on the load (air flow rate) and the pressure loss in the system. Some examples of fans and their power consumption according to flow and pressure drops are shown in the table below. Pictures of the fans are placed below the table.

Table 21 Examples of fan energy consumption

Brand, name	Type	Effect (W)		Flow (l/s)		Pressure loss (Pa)	
		From	To	From	To	From	To
EXHAUSTO DTH 160, roof fan	Centrifugal	10	25	10	100	12	100
EXHAUSTO BESB250-4-1	Centrifugal	40	100	150	330	50	240
Systemair TFER 125, roof fan	Centrifugal	32	32	10	47	10	150
Systemair CBF bathroom fan	Centrifugal	45	45	0	30	0	120

[?? insert figures from ESBENSEN contrinution]

From these examples it may be noted the fans use 10 – 100 W of power depending on the type, airflow and pressure drop.

3b.1b Actuators

Depending on the amount of work the actuator needs to deliver, i.e. the size of the opening, the power consumption varies. An example is given below.

NOVA Air damper : AC on/off electrical motor, for opening length between 480 mm to 6000 mm

- Standby: 0,05 W
- In operation: 3,5 W

3b.1c Sensors

Depending on the sensor type (CO2, temperature, infrared, etc.) and the brand, the power consumption for sensors roughly varies from:

- Standby: 0,15 mW (infrared sensor) to 4800 mW (CO2 sensor, telaire type)
- In operation: 0,15 mW (infrared sensor) to 200 mW (smoke detector)

Data from PHOTOVENT.

Generally it may be noted that it is possible to fully power actuators and sensors with PV. How much of the fan power can be powered, on the other hand, very much depends on the system.

3b.2 Integration of renewables

- This can become quite a wide field if considering also space heating, so here we concentrate only on ventilation-related energy consumption (system components & conditioning to offset ventilation gain/loss)
- Overview of types of renewable primary energy sources. The field is probably too big to cover; maybe focus on solar energy & wind, and not put so much on bio-fuels
 - Solar (active PV, active solar collector systems for ventilation heating ?, or passive)
 - Wind (active or passive)
 - Biofuels: biomass (wood, wood pellets)
 - all kinds of ambient energy from the outside air and from the ground
 - decentralized co-generation units, particularly on fuels cell systems
 - The field of electricity generation with renewables is probably too vast to mention in this state-of-are report:
 - wood gasification
 - wood heated sterling motors

- biogas driven cogeneration units
- biogas and solar produced H₂ driven fuel cells etc, etc.
- profile of sources (supply vs. demand profile, e.g. solar energy needs battery)
- product search and (market) availability
- Assess costs in order to know whether it competes with other energy saving solutions
- Identify blind spots for necessary products
- Wireless controls : how on earth can they get their power ?, e.g. mini PV cells on wall mounted sensors ?
- Identify benefits of “stand-alone” systems as opposed to ventilation components powered by the grid
- Or is the opposite effect true, where a large PV array sells surplus electricity to the grid ?

The facades and roofs of buildings are of special concern in RESHYVENT hence the building integration of renewable energy technologies focus on solar and wind applications to substitute fossil fuel in the operation of hybrid ventilation systems. This means that the buildings exposure to sun and wind are of great importance. The term, integration of renewables, covers a very large field of applications. This section only touches upon ventilation related energy consumption i.e. system components and conditioning to offset ventilation gain and losses.

The section is meant to give an overview of the possible types of renewable primary energy sources, the different technologies are not explained in detail, only mentioned as possible options.

3b.2a Solar (active and passive)

The solar energy field, applicable to ventilation systems, may be divided into the two main categories, solar power and solar thermal energy.

Solar power is delivered by installing active PV cells on the roof or facade of the building. Solar cells convert sunlight directly into electricity. They are made of semi-conducting materials similar to those used in computer chips. When sunlight is absorbed by these materials, the solar energy knocks electrons loose from their atoms, allowing the electrons to flow through the material to produce electricity. This process of converting light (photons) to electricity (voltage) is called the photovoltaic (PV) effect. Thin film technology has made it possible for solar cells to now double as rooftop shingles, roof tiles, building facades, or the glazing for skylights or atria, hereby integrating into the building. The PV cells can supply energy to the actuator, sensors or fans, depending on the system design, location on the building and climate zone. The PV technology and guide lines for the use of PV cells is described further in section 3b.3a1.

Solar thermal energy, can be used to pre-heat ventilation air, and may be delivered actively or passively. Passive solar heating design features include sunspaces (glazed balconies) and trombe walls. A sunspace is typically built on the south side of a building. As sunlight passes through glass or other glazing, it warms the sunspace. Proper ventilation allows the heat to circulate into the building. On the other hand, a trombe wall is a very thick, south-facing wall, which is painted black and made of a material that absorbs a lot of heat. A pane of glass or plastic glazing, installed a few inches in front of the wall, helps hold in the heat. The wall heats up slowly during the day. Then as it cools gradually during the night, it gives off its heat inside the building. Active solar heating is usually set up as direct preheating of the ventilation air through a solar air collector. More information and guide lines for the use of passive and active solar thermal energy may be found in section 3b.3a2 – 3b.3b5.

3b.2b Wind cowls

The expression, wind cowls, covers a large range of wind augmentation techniques, which are able to improve driving forces, or eliminate dependencies on wind directions, or to stabilise the air flow.

3b.2c Stack effect

A driving force for ventilation purposes may be initiated by using the stack effect. This effect is, however, not entirely a free energy source as the driving force is initiated by the temperature

difference brought about from the internal heat i.e. unless the room heat is delivered from renewables, this effect cannot be characterised as fully sustainable.

3b.2d Biofuels

Biopower, or biomass power, is the use of biomass to generate electricity. There are six major types of biopower systems: direct-fired, co-firing, gasification, anaerobic digestion, pyrolysis, and small, modular.

Most of the biopower plants in the world use direct-fired systems. They burn bioenergy feedstocks directly to produce steam. This steam is usually captured by a turbine, and a generator then converts it into electricity. In some industries, the steam from the power plant is also used for manufacturing processes or to heat buildings. These are known as combined heat and power facilities. The energy sources may be wood, wood pellets, straw etc. which is produced locally.

More information may be found at:

http://www.nrel.gov/clean_energy/biopower.html

3b.2e Decentralised co-generation units

A decentralised co-generation plant may use biomass as an energy source to produce electricity and heat. However, the fuel – cell technology is under development and looks promising. The theory of a fuel cell is relatively simple. Hydrogen and oxygen is combined to produce electricity, with water and heat as the by-product. The conversion of fuel to energy takes place without combustion; therefore the process is highly efficient, clean and quiet. Ultimately fuel cells are combined with solar and wind power technologies for the process of separating hydrogen from water, thereby establishing a total zero emission energy system.

There are many different types of fuel cells being developed. Recently a lot of companies have been using the PEFC technique (Polymer Electrolyte Fuel Cell) when working on small co-generation units.

More information may be found at:

www.fuelcells.org

www.eere.energy.gov

www.fuelcell-info.com

3b.3 Solar power (IEA SHCP task 19, 20; IEA PVPS; EU Joule)

3b.3a Active:

- PV: State of art in (cheap) stand-alone PV for auxiliary energy (avoiding electrical grids and wiring in dwellings)
- space/PV area/equipment (e.g. battery size) requirements
e.g. Night-time ventilation of heavyweight building (passive cooling) vs. PV battery
- lifetime of batteries, PV collectors
- price calculation avoiding wiring and electricity use against over costs PV
- Forecast drop in prices, impact of large-scale orders.

The following sections will give an outline of the most dominant solar technologies relevant for the use in hybrid ventilation systems.

PV systems

General description of Stand-alone PV systems

From a technical point of view photovoltaic technology is relatively simple. However there are still some crucial steps that must be taken in both the design and installation stages.

Types of systems

Stand-alone systems are usually categorized into three types, depending on whether they use battery storage and / or auxiliary power sources. Fig. 1 illustrates these categories.

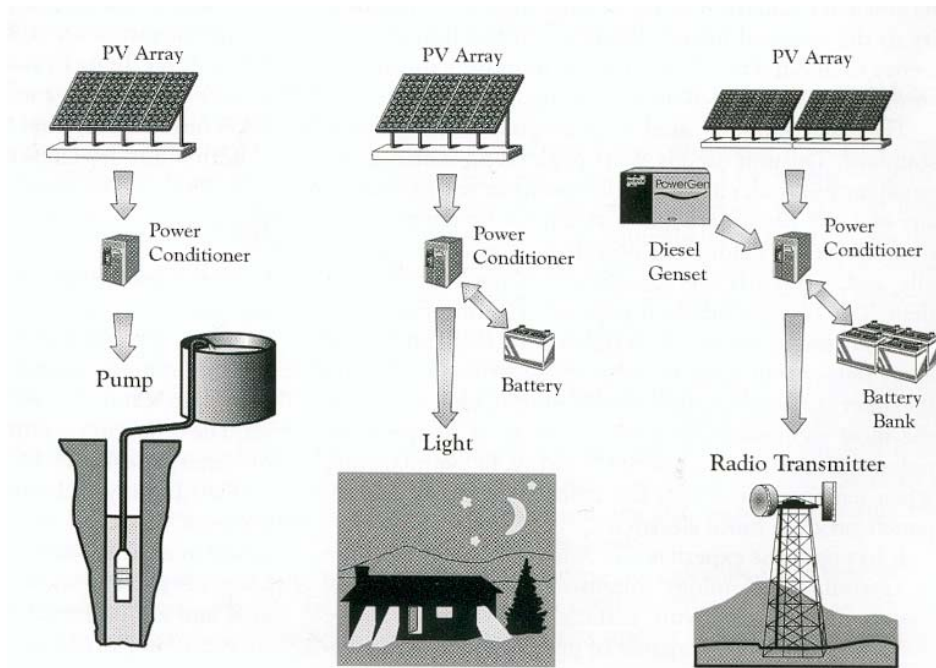

Figure 34 Types of Stand-Alone systems

The first type of Stand-alone is referred to as PV-direct because it powers the load directly, without using any battery. Such a system has the simplest configuration and is normally used either for applications that are not critical and match the availability of sunlight, such as calculators and ventilation fans, or when storage is already part of the system, such as water pumping. Despite the fact that PV powers the load directly, some form of power conditioning may still be required to operate the load properly and maximize the PV output.

The second type of PV system is PV with battery. This system includes storage that allows the load to be powered when the PV array cannot supply power directly (e.g. at night or during periods of low sunlight). This is the most common type of PV system as it suits a wide range of applications worldwide.

The third type of PV system, called PV hybrid, includes systems that rely on an auxiliary source to complement the low solar resource, generally a fossil fuel or wind generator. This type of system generally uses batteries too, for short-term variations of sunlight condition (on a daily or weekly basis). It is particularly suitable for applications that are critical (need additional backup) or those found in regions with large variations of sunlight conditions throughout the year, such as high latitude locations.

System control

All Stand-alone PV systems normally require some form of control or power conditioning. The complexity of the control function depends on system user requirements, the type of system and the number of power sources included. In simple systems, battery charge-controllers interface between the battery while the inverter interfaces between the battery and the AC-load. However, in case of hybrid systems, energy management can become more complex in order to improve the efficiency of the system. Some controllers integrate all the necessary functions to run a system.

Nowadays, sophisticated power conditioners offer options such as periodic equalizations, energy metering, temperature compensation, multipower source management capability (PV-Wind-Diesel hybrid for example), monitoring and remote access via modem.

General design parameters to consider before using PV

Before it can be determined whether PV is a feasible option, there are a number of parameters that need to be considered. The below table illustrates these parameters.

Main Item	Sub Issues	Example
Geography	Latitude	50° North (Brussels)
	Longitude	5° East
	Orientation	195° - 15° from south
	Tilt angle	90° - Vertical
Load profile	Input voltage range	6-12 Volt DC
	Power needed	2-6 Watts
	Time of consumption	6 Hours
	Period of consumption	Daily during summer, weekends in spring / autumn, none during winter.
	Consumption pattern	6-9 AM, 1-3 PM
Shadowing	Shadows occur	Yes / No
	Time of shadowing	Winter between 8-12 AM
Available area	PV	$L_{max} = 900 \text{ mm}$, $L_{min} = 400 \text{ mm}$
	Battery	$H_{max} = 100 \text{ mm}$, $L_{min} = 20 \text{ mm}$, $W_{max} = 25 \text{ mm}$
	Control device	$H_{max} = 100 \text{ mm}$, $L_{min} = 80 \text{ mm}$, $W_{max} = 50 \text{ mm}$
Wiring	Distance between battery and consumption	2 m
	Distance between PV location and battery	0,5 m
	Distance between PV location and controller	0,5 m
Weather conditions	Average ambient temperature	Summer +22°C, Winter 2°C
	High / Low ambient temperature	-25°C to +42°C
	IP class needed for battery	IP 22
	IP class needed for controller	IP 65
Feasibility	Cost of kWh	0,13 Euro / kWh
	Price to power the component (AC transformer, cabling and installation cost, battery cost)	14 Euro
	Electrical maintenance cost	5 Euro per year
Integration	Possibility to integrate PV	Yes, front of inlet – 0,36 m ²
	Possibility to integrate battery	Yes, inside inlet – 20 cm ³
	Possibility to integrate controller	No
	Design requirements	"Black PV module look"

Photovoltaic technology

A photovoltaic cell is a semiconductor device that produces electricity from photons (sunlight). A series of cells is interconnected on a panel, with electric output ranging up to 300 Wp. The function of the panel or module is to allow building integration and to protect the cells from the weather. Multiple panels may then be interconnected to form a string, and several strings may be used in parallel to form an array.

Silicon is the main semiconductor used in commercial cells. Panels marketed are mostly made from mono-, polycrystalline or amorphous silicon cells. Many other materials are being developed but have not yet achieved the production level of silicon cells.

While conventional mono-crystalline cells have an efficiency of 13-17% and poly-crystalline about 12-15%, relatively high efficiencies (about 20%) are achieved by using new mono-crystalline cells with embedded contacts and a grooved surface area. Amorphous silicon is the least efficient of the commercial silicon based products; While its efficiency is in the 8-10% range when new, instability of the material lowers efficiency to a stabilized efficiency of about 4-7% after a few months exposure to sunlight.

The panel output is rated according to an international standard. The unit used is Watt peak (W_p), which is the panel output under a given light spectrum with an intensity of 1 kW pr. m² at a module temperature of 25°C. In the field, peak power only occurs occasionally, and, as a yearly average, panels will produce no more than 20% of their rated output over a 24 hour period.

Light conditions vary throughout the day and the PV array output will vary accordingly. Among the other factors that affect the PV output, temperature is the most significant. In general, a rise in temperature reduces performance of the PV array. In a similar way, when temperature drops, the voltage increases and PV panels produce more electricity.

It has been the experience in Australia that in the case of crystalline technology (mono- or poly-), a PV panel frequently operates with surface temperatures above 60°C, when it is only capable of producing around 80% of its rated capacity. However in the same temperature environment, the efficiency of an amorphous silicon array is relatively unaffected.

The table below sums up the technologies:

Technology	Commercial efficiency (%)	Commercial size (m ²)	Yield pr. m ² (Wp / m ²)	Price pr. Wp (Euro / Wp)
Monocrystalline	13-17	0,4-1,5	130	4,30 - 5,20
Polycrystalline	12-15	0,5-1,5	120	4,00 - 5,00
Amorphous	4-7	0,2-0,8	40	3,00 - 10,00

Battery Technology

For the applications requiring energy at night or during periods of low sunlight, a storage medium must be used to ensure the autonomy of the system. Most Stand-alone systems require storage. The usual storage equipment used with Stand-Alone systems are rechargeable batteries. The following is a brief overview of the different types of batteries used with PV systems.

Two battery technologies are generally found in PV systems: Lead acid and metallic (NiCd – Lithium). Both can be found in a variety of sizes and capacities. Metallic batteries present some technical advantages over lead-acid and are preferred for certain applications. However, they are 3-4 times more expensive per unit of energy stored and consequently lead-acid batteries are more commonly used.

Lead-acid and metallic batteries are divided in two categories: open units (often referred to as "vented"), and sealed units (also called "valve-regulated"). When overcharged, batteries produce hydrogen and oxygen, and there is also a consequential loss of water. In open batteries, this loss needs to be compensated at intervals. Sealed units, when properly operated, will minimize this loss; for this reason, these are generally considered to be "maintenance-free" batteries. However, if they are mistreated and over-charged, a valve will let the battery vent, which will result in permanent damage, since water cannot be added to these units.

Other characteristics, such as the construction of the plate and the type of electrolyte used, make some batteries more appropriate under certain operating conditions. For instance, solar powered telecommunications systems included batteries designed to provide back-up power. The duty cycle involves infrequent and relatively light discharges compared to batteries used in most other duty cycles. Starter batteries as applied in vehicles, are designed to accommodate frequent sharp, but shallow discharges. Batteries designed for renewable energy systems must withstand regular deep discharges. Because batteries are designed to suit a particular duty cycle it is important that the correct type of battery is selected for a given application.

The table below sums up the technologies:

Technology	Commercial size (cm ³)	Voltage level (Volt)	Rated power (Wh)	Ambient temperature (°C)	Price pr. Wh (Euro / Wh)
Lead Acid – Open	120 – 25.000	6 – 12	6 – 2.000	-20 to +50	0,05 – 0,40
Lead Acid – Closed	120 – 50.000	6 – 12	6 – 2.000	-20 to +50	0,10 – 1,00
NiCd	5 – 50	1,2 – 9,0	0,36 – 2,4	-20 to +50	1,00 – 2,00
Lithium – Ion	10 – 30	3,7 – 9,0	3,7 – 7,4	-20 to +50	2,75 – 3,25

Load vs. Supply

In dimensioning PV systems it is necessary to define the load profile and the solar irradiation. In periods where there is not enough sunlight, a backup medium is required. This is symbolized in the below figure:

Figur 2: Supply vs. Load - yearly basis

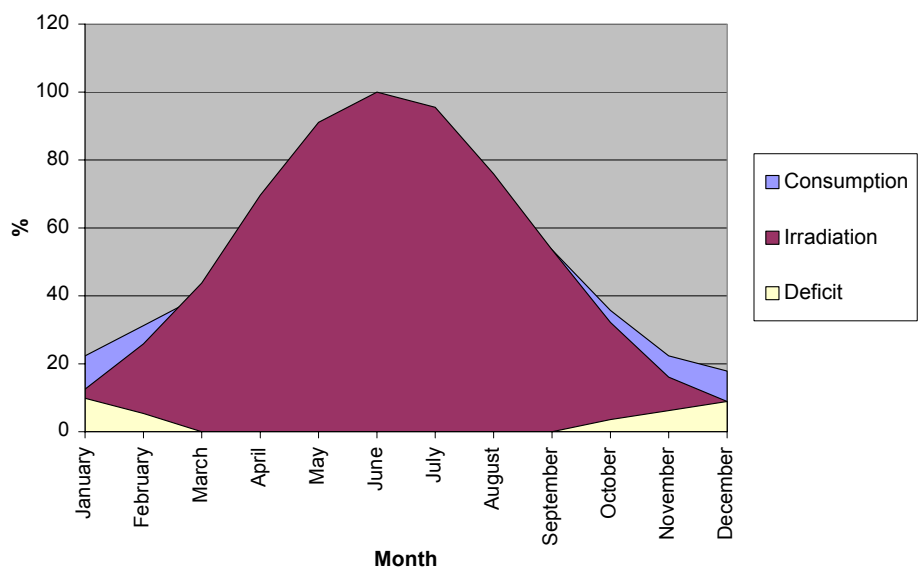
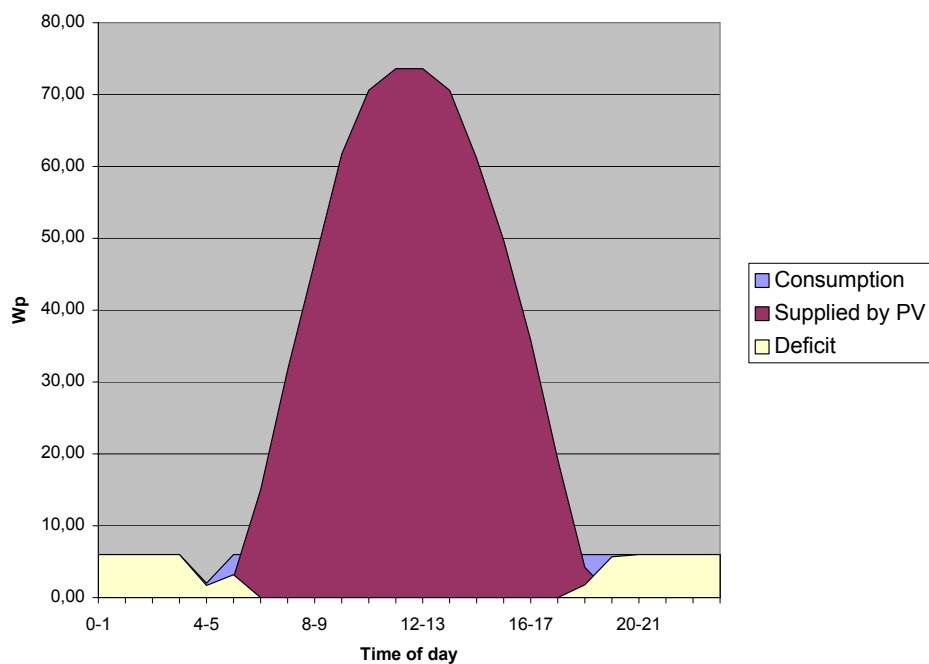
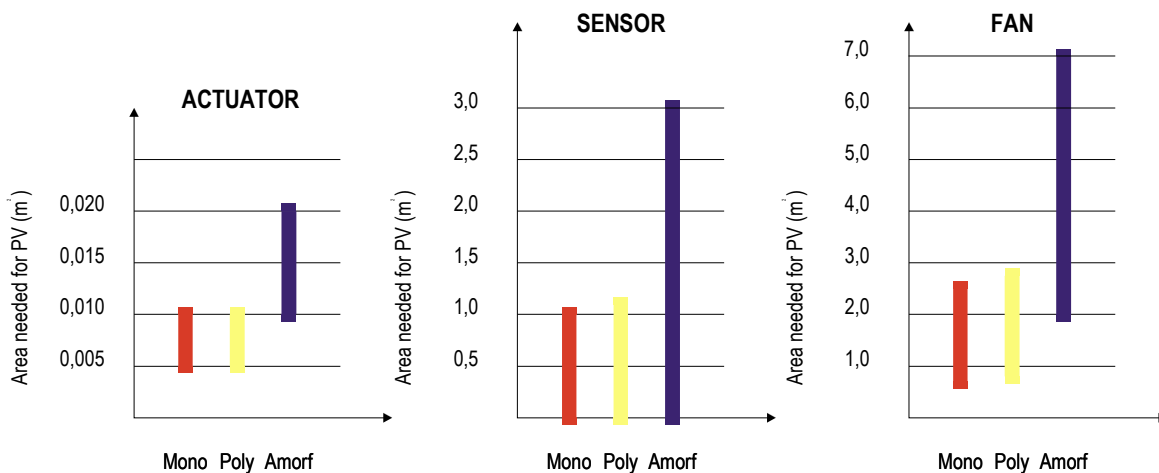

Figure 3: Supply vs. Load - Daily basis



Expected areas needed for PV

As a rule of thumb the below tables show the expected area needed for PV systems. A number of assumptions have been made, as it is crucial to look into every component specifically.



Expected battery sizes

It is very difficult to generalize the required battery sizes. They depend on the ventilation strategy, geography, ambient temperatures, the selected PV size and backup period needed. For each component it is necessary to design the battery bank.

However it is clear that actuators need only small batteries (AAA sizes) while fans need larger battery banks (between 500-2000 Wh).

Sensors are still under development and different brands and types have different consumptions.

Feasibility of supplying components with PV (Conclusion)

As stated above it is very difficult to say anything in general about the feasibility of supplying components with PV. That is why so many issues under chapter 2 are listed. A careful review of each component must be done.

However under certain assumptions it is clear that at least some components may be supplied with electricity through PV systems.

Actuators, as they have been described in the Photovent project, seem very likely to be suppliable by PVs. They have small consumptions and are close to the exterior. Probably all inlets, even north-facing, can be supplied by a rather small PV module and battery. Control units can probably be excluded.

For sensors it is very difficult to say anything in general. It depends on the type, use and brand. There seems to be some development underway that can increase the likelihood of supplying sensors with PV-generated electricity. Some prototyping and testing over a longer period needs to be done.

Fans need more PV power, control units and a battery bank. However these are typically placed near the exterior and other considerations such as environmental issues should be considered. In general more studies need to be done in order to conclude anything about the suitability of PVs in powering fans.

Product information on PV systems

Shell Solar Energy BV (The Netherlands)

Gaia Solar A/S (Denmark)

Dunasolar (Hungary)

Grenaa Marine Solarafdeling (Denmark)

Steca (Germany)

Varta (Denmark)

Danionics (Denmark)

MPX Electra (Denmark)

GP batteries (Denmark)

Solar air systems

General description

Active solar systems for air heating are a straightforward yet effective way of applying solar energy for space heating and tempering ventilation air. The systems offer some advantages over solar water systems, e.g. no boiling/freezing risks. The systems can offer improved comfort and fuller use of solar gains than passive solar systems and are a natural fit with mechanically ventilated buildings.

The systems can be economical, with short pay-back periods, and can be used for space heating, pre-heating of ventilation air, water pre-heating, sunshading, electricity generation (with hybrid photovoltaic systems) and to help induce cooling.

However, designers lack experience in planning, analysing and constructing such systems. Within the project IEA Solar Heating and Cooling Programme Task 19, three publications have been made to bridge the information gap. This is done, by illustrating a range of successful applications, pointing out suppliers of the necessary equipment and offering a comprehensive handbook to lead designers through the necessary design processes.

Some of the main advantages and critical aspects for solar air systems are listed below:

Advantages:

- Fast responding
- Easily controlled
- Leaks are not a serious problem
- No anti-freeze chemicals are needed

Critical aspects:

- Large channel cross-sections
- Potential noise problems
- Electrical consumption by fans
- Dust and moisture

The technology

A solar air heating system uses the sun's energy to preheat the ventilation air and may therefore also be used for space heating purposes. In a typical system, fresh air is drawn across a heat absorbing south-facing wall or other form of solar collector. The pre-heated air is drawn into a building's primary heating system where it is further heated, then distributed throughout the building.

The solar air system roughly consist of the following components:

- Collector
- Duct system
- Diffusers
- Fan, filters, dampers and noise reducers

There are 6 different types of solar air systems:

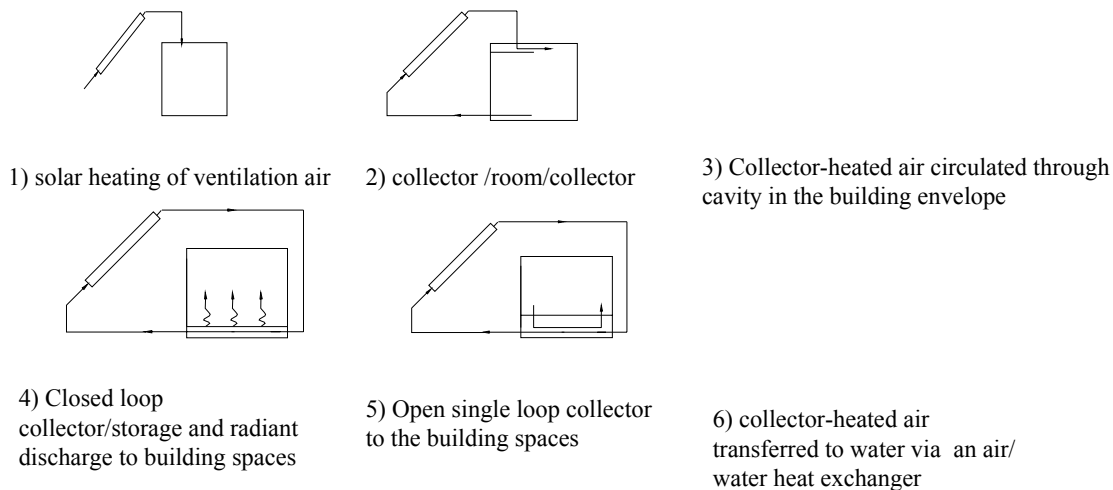

Of these systems, system no.1, solar heating of ventilation air, is the most relevant in relation to hybrid ventilation as this system preheats fresh air. The other systems are closed systems where room air is heated by circulating through the collector.

There are four main airflow principles in solar air collectors; flow below the absorber, flow above the absorber, flow on both sides of the absorber and perforated absorber. The perforated absorber usually has the highest efficiency.

General design parameters

The main design parameters for a solar ventilation system is the ventilation rates i.e. the total air change in the building accounting for the infiltration.

In the book Solar air Systems - A Design handbook by S. Robert Hastings and Ove Mørck, 2000, different nomograms have been generated based on different climatic conditions. By using these, the system performance of a solar air system can quickly be approximated.

The following table shows the necessary design parameters.

Main design items	Example
Location	Denmark
Weather condition	Cloudy, temperate climate
Size of building	100 m ²
Tilt	45°
Orientation	15° from south towards east
Collector type and size	Optimised collector of 5 m ² i.e. 0.05 m ² / m ² _{floor}
Air flow through collector	100 m ³ /h, i.e. 1 m ³ /h m ² _{floor}
Control strategy	Temperature controlled. The fan of the solar heating system starts at a collector temperature of 18°C and stops at a collector temperature of 16°C. The fan also stops if the temperature in the building exceeds 23°C.
Fan power	100 W with 50% dissipation in the air stream
Space heating demand	12,500 kWh/year, i.e. 125 kWh/m ² _{floor} per year
U-value of roof	0,75 W/m ² K

When these parameters are identified the nomograms are used and the annual saved energy is found.

Using the design parameters listed above the savings will amount to 176 kWh/m² collector per year. When including the dissipated fan energy and the saved energy loss through the roof (or facade), the annual saved energy amounts to 200 kWh/m² collector per year.

A more detailed description of the design method is written in Solar air systems – a handbook, where the nomograms may also be found.

Feasibility

Generally the performance from a solar air system is in the range 50-250kWh/m² collector area. /BPS, Luftsolvvarmeanlæg, publication 133, 2000/ It is however, not possible to generalise the cost-effectiveness of a system for pre-heating of ventilation air and /or space heating as it usually is very dependant on the system and building.

It must however be noted that there are other benefits, in addition to energy cost savings that can be gained by applying a solar system, e.g. environmental aspects and improved thermal comfort. /IEA, SHC programme task 20, Solar collectors in renovation projects/

Product information

Solahart (AU)
Grammer (D)
Aidt Miljø (DK)
Larsen (A)
Solarwall (C)
The Friendly Wall (N)
Secco (I)

General

The following information was obtained in the PHOTOVENT project (1998-2000) in which PV-powered smart ventilation devices were developed. The information was partly received from the Belgian Engineering office 3E (Engineering a Sustainable Energy Future).

Energy storage

The boundary conditions of the energy storage element are mainly:

- storage capacity (determined by the energy consumption of all system components and also available energy in terms of Wp and irradiation), voltage and self-discharge;
- physical dimensions in order to allow for integration into the device;
- life time

Due to low energy consumption of flap motor and control unit the use of a capacitor was an option to check:

- *Using one 2.3V/100F capacitor:* an autonomy of the system of 2.1 days is resulting (264J/d stored energy x efficiency of needed DC/DC-converter 80% / (self-discharge 40J/d + system consumption 59 J/d)).
- *Using several 2.3V/100F capacitors:* (connected in series to obtain the required voltage-level) would cause problems to integrate into ventilation grille (too less of space available).

This shows that the energy storage cannot be done under the use of capacitors.

Different battery technologies were investigated (Pb-Acid, NiCd, NiMH, Li-ion, innovative Li-Vanadium). Battery options have evolved with the decreasing energy consumption of the consecutive prototypes; with the low energy consumption of the latest prototype with indirect drive servomotor the interesting option of a very compact tubular (diam. 34mm) Pb-Acid battery became possible. The battery had a nominal voltage of 2V (2.5 resp. 4 Ah) and therefore a DC-DC converter was necessary to supply a stable 5V to the electronics.

Temperature aspects

In case of using crystalline silicon PV-cells the temperature does have an influence on the voltage. Per increased K of the PV-cell temperature the mpp-voltage (maximum power point) is reduced for 0.5% (against nominal mpp-voltage). As the critical working period of the ventilation device is during the winter months and at north orientation the temperature aspects are of importance for the selection of the working voltage.

The voltage of amorphous silicon cells is nearly temperature-stable.

In Table 22, an overview of available system components and their electronic characteristics, prices, power consumption and dimensions is elaborated. Besides, a spreadsheet calculation

was established (IMEC) to make the preliminary design of a system regarding use of possible components, resulting in the size of the PV-element required to power them.

Table 22a Characteristics of available system components

item name	item type	capacity (Ah)	stored energy (J)	voltage (V)		current (mA)	
				voltage type	stand-by	in operation	
sliding ventilator	motor			24	DC/AC	0	41,67
stepper motor	motor			5	DC		340,00
thermal motor	motor			24	DC	125	
airtop ventilator	motor			24/230	DC/AC		
presence infra-red sensor	sensor			5	DC	0,03	0,03
infra-red counting gate	sensor			5	DC	50	0,05
capacitive humidity sensor	sensor			5	DC	1	1,00
mechanical humidity sensor	sensor			5	DC	9	9,00
smoke detector	sensor			10	DC	20	20,00
CO2 sensor (telaire type)	sensor			12	DC	400	
temperature sensor (LM35)	sensor			5	DC	0,06	0,06
pressure sensor	sensor			5	DC		
photocell	sensor					0	0,00
tacho-anemometer	sensor			5	DC	10	10,00
gonio-anemometer	sensor			5	DC	1	1,00
AERECO BHM	system			9	DC	0,0001	400,00
AERECO MRA AGITO	system			5 / 12	DC	1	0,30
AERECO MRA PRESENCE	system			6 / 9	DC	0,15	0,30
battery charger 6V	control unit			6	DC	10	15,00
battery charger 6V LVD	control unit			6	DC		40,00
battery charger 12V	control unit			12	DC	10	15,00
battery charger 12V LVD	control unit			12	DC		
battery charger 24V	control unit			24	DC	10	15,00
battery charger 24V LVD	control unit			24	DC		
battery sealed Pb-Ac 6V 1.2Ah	battery	1,20	25920	6	DC		
battery sealed Pb-Ac 6V 3Ah	battery	3,00	64800	6	DC		
battery sealed Pb-Ac 6V 1.0 Ah	battery	1,00	21600	6	DC		
battery sealed Pb-Ac 6V 1.2 Ah	battery	1,20	25920	6	DC		
battery sealed Pb-Ac 6V 2.8 Ah	battery	2,80	60480	6	DC		
battery sealed Pb-Ac 12V 1.2 Ah	battery	1,20	51840	12	DC		
battery sealed Pb-Ac 12V 2.0 Ah	battery	2,00	86400	12	DC		
battery sealed Pb-Ac 12V 2.1 Ah	battery	2,10	90720	12	DC		
battery sealed Pb-Ac 12V 2.3 Ah	battery	2,30	99360	12	DC		
battery sealed Pb-Ac 12V 2.8 Ah	battery	2,80	120960	12	DC		
battery sealed Pb-Ac 12V 3.2 Ah	battery	3,20	138240	12	DC		
battery sealed Pb-Ac GEL 6V 1.2 Ah	battery	1,20	25920	6	DC		
battery sealed Pb-Ac GEL 6V 3.5 Ah	battery	3,50	75600	6	DC		
battery sealed Pb-Ac GEL 12V 1.2 Ah	battery	1,20	51840	12	DC		
battery sealed Pb-Ac GEL 12V 2.0 Ah	battery	2,00	86400	12	DC		
battery sealed Pb-Ac GEL 12V 3.5 Ah	battery	3,50	151200	12	DC		
battery sealed Pb-Ac 2V 2.5 Ah	battery	2,50	18000	2	DC		
battery sealed Pb-Ac 2V 4.5 Ah	battery	4,50	32400	2	DC		
battery sealed Pb-Ac 2V 5 Ah	battery	5,00	36000	2	DC		
battery sealed Pb-Ac 2V 8 Ah	battery	8,00	57600	2	DC		
battery Li-ion 3.7 V 0.83 Ah	battery	0,83	11055,6	3,7	DC		
battery Li-ion 3.7 V 1.25 Ah	battery	1,25	16650	3,7	DC		
battery Li-ion 3.7 V 1.4 Ah	battery	1,40	18648	3,7	DC		
battery Li-ion 3.7 V 1.5 Ah	battery	3,70	49284	3,7	DC		
capacitor PC10 2.3V 8F	capacitor		26	2,3	DC	0,02	
capacitor PC0323 2.3V 100F	capacitor		264	2,3	DC		
capacitor PC0323 12V 1F	capacitor			12	DC		

Table 22b Characteristics of available system components (contd)

item name	item type	power consumption (mW)		energy (mWh)	
		stand-by	in operation	stand-by (24h)	1 operation
sliding ventilator	motor	0	1000	0	
stepper motor	motor	0	1700	0	1000
thermal motor	motor	3000	0	72000	
airtop ventilator	motor	0	35000-45000	0	
presence infra-red sensor	sensor	0,15	0,15	3,6	
infra-red counting gate	sensor	250	0,25	6000	
capacitive humidity sensor	sensor	5	5	120	
mechanical humidity sensor	sensor	45	45	1080	
smoke detector	sensor	200	200	4800	
CO2 sensor (telaire type)	sensor	4800	0	115200	
temperature sensor (LM35)	sensor	0,3	0,3	7,2	
pressure sensor	sensor	0	0	0	
photozell	sensor	0	0	0	
tacho-anemometer	sensor	50	50	1200	
gonio-anemometer	sensor	5	5	120	
AERECO BHM	system	0,0009	3600	0,0216	0,3
AERECO MRA AGITO	system	12	1,5	288	
AERECO MRA PRESENCE	system	0,9	2,7	21,6	0,0003
battery charger 6V	control unit	60	90	1440	
battery charger 6V LVD	control unit	0	240	0	
battery charger 12V	control unit	120	180	2880	
battery charger 12V LVD	control unit	0	0	0	
battery charger 24V	control unit	240	360	5760	
battery charger 24V LVD	control unit	0	0	0	
battery sealed Pb-Ac 6V 1.2Ah	battery	0	0	0	
battery sealed Pb-Ac 6V 3Ah	battery				
battery sealed Pb-Ac 6V 1.0 Ah	battery				
battery sealed Pb-Ac 6V 1.2 Ah	battery				
battery sealed Pb-Ac 6V 2.8 Ah	battery				
battery sealed Pb-Ac 12V 1.2 Ah	battery				
battery sealed Pb-Ac 12V 2.0 Ah	battery				
battery sealed Pb-Ac 12V 2.1 Ah	battery				
battery sealed Pb-Ac 12V 2.3 Ah	battery				
battery sealed Pb-Ac 12V 2.8 Ah	battery				
battery sealed Pb-Ac 12V 3.2 Ah	battery				
battery sealed Pb-Ac GEL 6V 1.2 Ah	battery				
battery sealed Pb-Ac GEL 6V 3.5 Ah	battery				
battery sealed Pb-Ac GEL 12V 1.2 Ah	battery				
battery sealed Pb-Ac GEL 12V 2.0 Ah	battery				
battery sealed Pb-Ac GEL 12V 3.5 Ah	battery				
battery sealed Pb-Ac 2V 2.5 Ah	battery				
battery sealed Pb-Ac 2V 4.5 Ah	battery				
battery sealed Pb-Ac 2V 5 Ah	battery				
battery sealed Pb-Ac 2V 8 Ah	battery				
battery Li-ion 3.7 V 0.83 Ah	battery				
battery Li-ion 3.7 V 1.25 Ah	battery				
battery Li-ion 3.7 V 1.4 Ah	battery				
battery Li-ion 3.7 V 1.5 Ah	battery				
capacitor PC10 2.3V 8F	capacitor	0,046		1,104	
capacitor PC0323 2.3V 100F	capacitor				
capacitor PC0323 12V 1F	capacitor				

Table 22c Characteristics of available system components (contd)

item name	item type	price/piece (€)	remarks	dimensions
sliding ventilator	motor		torque required > 2 Nm	
stepper motor	motor			
thermal motor	motor			
airtop ventilator	motor			
presence infra-red sensor	sensor	22		
infra-red counting gate	sensor	80		
capacitive humidity sensor	sensor	50		
mechanical humidity sensor	sensor	35		
smoke detector	sensor	40		
CO2 sensor (telaire type)	sensor	400		
temperature sensor (LM35)	sensor	12		
pressure sensor	sensor	45		
photocell	sensor	10		
tacho-anemometer	sensor	50		
gonio-anemometer	sensor	40		
AERECO BHM	system			
AERECO MRA AGITO	system			
AERECO MRA PRESENCE	system			
battery charger 6V	control unit		can be reduced by omitting LED-indicators	
battery charger 6V LVD	control unit			"
battery charger 12V	control unit			"
battery charger 12V LVD	control unit			"
battery charger 24V	control unit			"
battery charger 24V LVD	control unit			"
battery sealed Pb-Ac 6V 1.2Ah	battery	13	ices : retail price +	51*97*25 mm (H*L*B)
battery sealed Pb-Ac 6V 3Ah	battery	15		60*134*34 mm
battery sealed Pb-Ac 6V 1.0 Ah	battery	15		57.5*51*42.5 mm
battery sealed Pb-Ac 6V 1.2 Ah	battery	11		57.5*97*25 mm
battery sealed Pb-Ac 6V 2.8 Ah	battery	13		67*134*34 mm
battery sealed Pb-Ac 12V 1.2 Ah	battery	15		54.5*97*48mm
battery sealed Pb-Ac 12V 2.0 Ah	battery	35		89*150*20mm
battery sealed Pb-Ac 12V 2.1 Ah	battery	18		67*178*34mm
battery sealed Pb-Ac 12V 2.3 Ah	battery	17		67*178*34mm
battery sealed Pb-Ac 12V 2.8 Ah	battery	20		67*134*67mm
battery sealed Pb-Ac 12V 3.2 Ah	battery	13		67*134*67mm
battery sealed Pb-Ac GEL 6V 1.2 Ah	battery	21	gel	54.9*97.3*25.5mm
battery sealed Pb-Ac GEL 6V 3.5 Ah	battery	32	gel	64.4*134.5*34.8mm
battery sealed Pb-Ac GEL 12V 1.2 Ah	battery	31	gel	54.9*97.5*49.5mm
battery sealed Pb-Ac GEL 12V 2.0 Ah	battery	39	gel	64.4*178.8*34.1mm
battery sealed Pb-Ac GEL 12V 3.5 Ah	battery	52	gel	64.4*134*66.3mm
battery sealed Pb-Ac 2V 2.5 Ah	battery	6	long-life (8-10y)	67.3*35.5 mm(L*Diam)
battery sealed Pb-Ac 2V 4.5 Ah	battery	8	long-life (8-10y)	103*34mm
battery sealed Pb-Ac 2V 5 Ah	battery	8	long-life (8-10y)	80.3*46mm
battery sealed Pb-Ac 2V 8 Ah	battery	13	long-life (8-10y)	109*44mm
battery Li-ion 3.7 V 0.83 Ah	battery			49.5*17mm (L*Diam)
battery Li-ion 3.7 V 1.25 Ah	battery			66.7*17mm
battery Li-ion 3.7 V 1.4 Ah	battery			62.3*18.3mm
battery Li-ion 3.7 V 1.5 Ah	battery			64.7*18.3mm
capacitor PC10 2.3V 8F	capacitor			24*31*4.5mm
capacitor PC0323 2.3V 100F	capacitor			51*33.3*15.9mm
capacitor PC0323 12V 1F	capacitor			

3b.3b Passive:

- Solar chimneys:
 - What's the solar chimney performance in different seasons ?
 - What's the decline in driving force for direct and indirect solar radiation ?
 - What's the solar chimney sensitivity to wind in terms of backflow ?
 - Is there a possibility to have a solar chimney assisted with a wind scoop ?

- Solar preconditioning of supply air :
 - Trombe wall,
 - Canadian solar wall (black aluminium panels with small perforations, used to preheat the fresh air). Has been used for housing as well as large warehouses.
 - Atria for preheating of air
 - Other systems

Solar walls (passive & active)

General description

Solar walls may be designed as either passive or active systems. They can be integrated into the building facade or added to the façade at a later time. A solar wall is characterised as a solar air system which makes use of the thermal mass in the facade.

The technology

The principle of a solar wall is illustrated in the figure below. The thermal mass in the facade is built heavy e.g. of a material for example concrete which is able to store and conduct the heat.

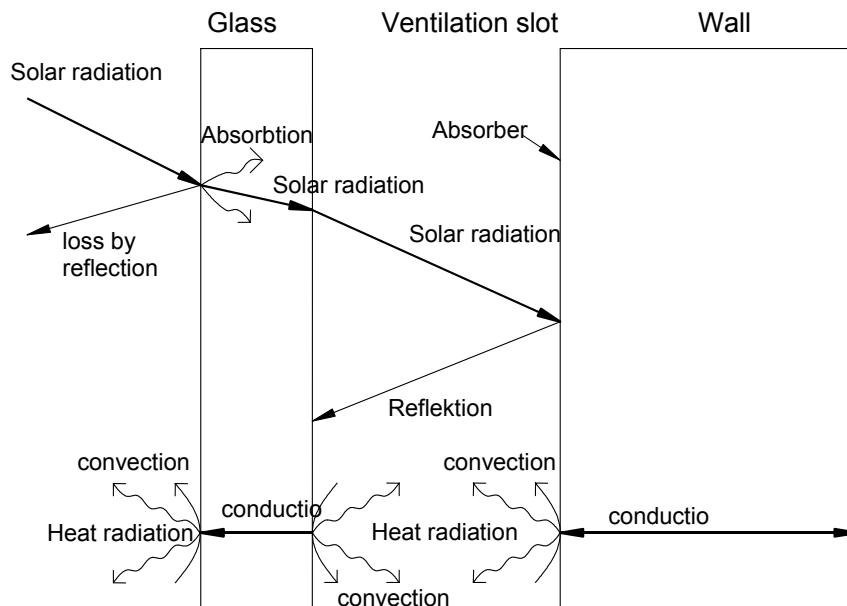

In this section four different types of solar walls are represented.

<p>The mass wall:</p> <p>The mass wall consists of a translucent cover mounted on a heavy facade wall. The sun heats the surface of the wall. The Heat is transported via conduction through the wall into the building. The heat will reach the inside of the building with a delay of about 6-8 hours. At low solar radiation no heat is conducted through the wall. However, the stored heat in the wall will reduce the heat loss from the building through the wall. The wall can be built at low cost and by using translucent insulation the performance is increased. /O. Holck/</p>	
--	--

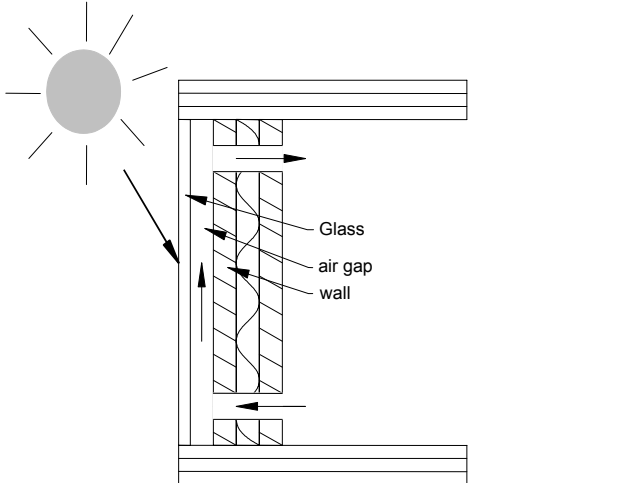
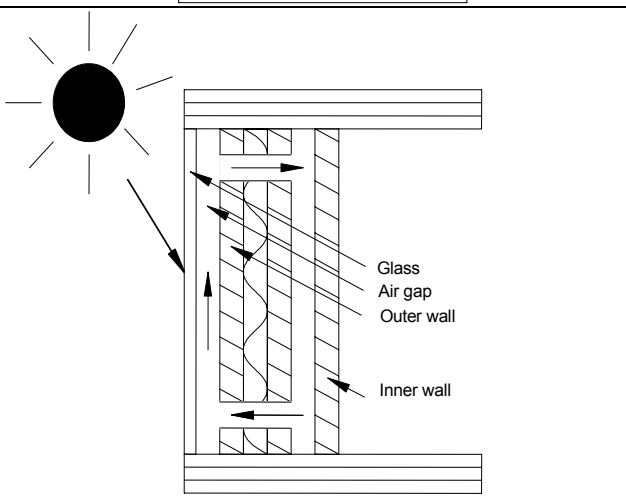
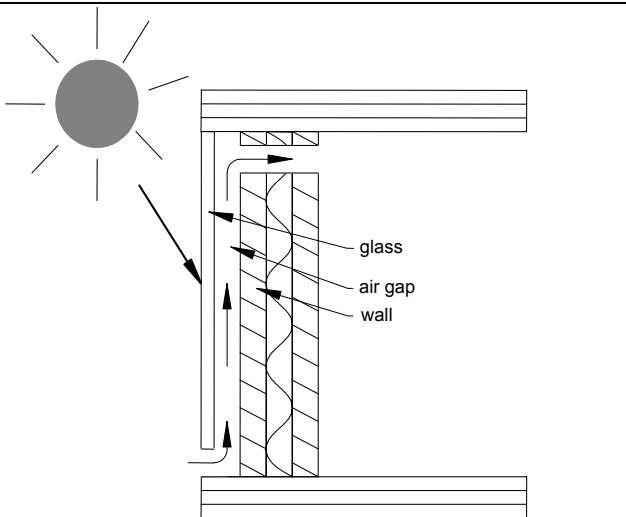
<p>Trombé wall:</p> <p>Room air is circulated directly between the cover and the wall. The heat is directly transferred to the room by the circulating air, which is guided through openings in the wall, and indirectly the heat is transferred by heat conduction from the wall.</p>	
<p>Ventilated mass wall</p> <p>Air is circulated between two vertical air gaps in the solar wall. The outer air gap is situated between the translucent cover and an insulated outer wall, whereas the inner air gap is situated between the insulated wall and a heavy inner wall. A damper is needed to prevent backward circulation of the air ventilated internally in the wall. The heat transfer occurs via convection and conduction.</p>	
<p>Pre-heating of ventilation air</p> <p>The fresh air is circulated behind a cover and in front of the outer wall, which may be a mass or insulated wall. If the wall is a mass wall (thermal heavy) the heat accumulation will reduce the heat loss from the building. The heat loss may be further reduced by adding translucent insulation during the building of the solar wall. If the wall is traditionally insulated the wall will minimise the heat loss but not deliver any noticeable heat storage</p> <p>/Luftsolvarme anlæg, BPS publikation 133, 2000/</p>	

Some of the general design parameters, which must be considered when installing a solar wall are listed in the following.

The building:

- The solar facade should not be more than 45 degrees from south-facing
- Avoid shadowing of larger portions of the facade

Heat transport and storage:

- The cover system should be designed to have a high solar transmittance and absorbtance

- The heat loss coefficient from the absorber to the surroundings should be as low as possible
- Heat transport from absorber to the storage should have a large heat capacity and mass.

Thermal comfort precautions:

- Bypass of the solar wall must be installed or shading of the solar wall must be installed in order not to experience over heating.
- Inlet whit diffusers (max 0.25 m/sec in comfort zone)

The efficiency of the solar wall largely depends on the correct combination of the solar wall components and the characteristics of the facade wall. The joints between the components must be tightly sealed. The more precisely the air-flow and heat energy is controlled, the larger the efficiency. The largest efficiency is usually obtained by using system 3. The ventilated mass wall or system 4. The pre-heating of ventilation air. /Luftsolvarme anlæg, BPS publikation 133, 2000/

Feasibility

It is not possible to generalise the cost-effectiveness of a system for pre-heating of ventilation air and /or space heating as it is usually very system and building-specific. It must however be noted that there are other benefits, in addition to energy cost savings that can be gained by applying a solar system, e.g. environmental aspects and improved thermal comfort. /IEA, SHC programme task 20, Solar collectors in renovation projects/

Product information

There are only a few manufactures that specialise in solar air systems. Most air-based systems used in existing renovations projects have been bespoke designs. /IEA, SHC programme task 20, Solar collectors in renovation projects/

Glazed balconies

General description

A glazed balcony means enclosing a balcony with a glazed facade element, while keeping a separation between the balcony and the rooms behind it. The fresh ventilation air enters the balcony and is pre-heated by the sun and by transmission losses from the building.

Some advantages and critical aspects are listed in the following.

Advantages:

- Solar energy can pre-heat the ventilation air
- Reduction of transmission and ventilation losses
- The utility of the space is enhanced
- Architectural image is enhanced

Critical aspects:

- Risk for overheating in summer
- The high effect of different user behaviour on energy savings
- Risk of condensation of moisture from the apartment on the glazed balcony windows
- Static strength of the balcony structure

The technology

Outside air usually enters the balcony at the bottom and is ventilated through the whole dwelling. The optimal effect is obtained by having a regulated exhaust of the ventilation air. There is no need to introduce a balanced ventilation system.

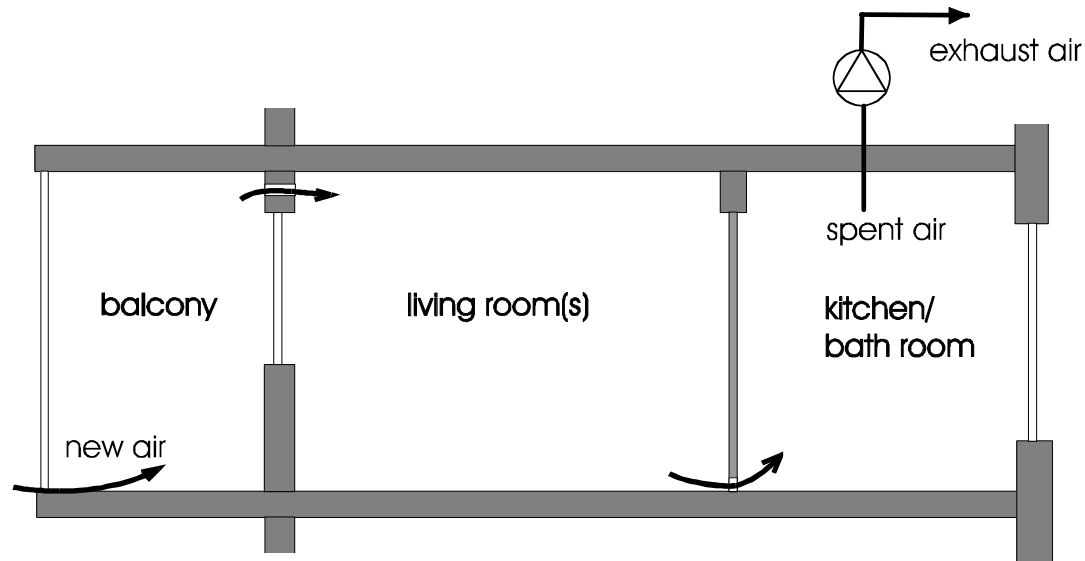

General design parameters

The main design parameters that should be considered when building a glazed balcony are listed below.

- Low-E glass should be used in either the inner or the balcony facade
- Windows should be openable in summer (1,2 –1,5 m²)
- The ventilation air should be preheated using the exhaust ventilation system
- The facade elements must be made strategically more airtight
- Provision of adequate shading devices

/IEA, SHC programme task 20, Glazed balconies in renovation projects/.

Feasibility

The price of a glazed balcony depends on the building type, the size of the area that has to be glazed and specific features i.e. type of glass, frame etc. A glazed balcony also saves operational and maintenance costs, because some maintenance tasks have been made unnecessary. The cost of a standard renovation can therefore be higher or lower than a solar renovation with glazed balcony.

In general, a glazed balcony is not cost-effective if it is considered only as a means to save energy and reduce maintenance. /IEA, SHC programme task 20, Glazed balconies in renovation projects/.

Product information

There are several available products on the market that will match the requirements of existing balconies reasonably well. For single glazing, standard window frames or metal frames such as those designed for greenhouses in horticulture may be used. When double-glazing or low E glazing is used in the outer facade, heavier frames may be needed. In addition, standard sliding and hinged windows and doors are available. Most standard products are of good quality. The installation quality depends on the skill of the workers. Weak points are where the frames are sealed to the existing walls.

Solar chimneys

General description

A solar chimney works as a natural-draft device that uses solar radiation to move air upward, thus converting thermal (heat) energy into kinetic (motion) energy. At constant pressure air density decreases with increasing temperature. Air with a temperature higher than ambient air temperature is driven upwards by the buoyancy force. This physical phenomenon is exploited

in passive stack ventilation. Air inside a building has very often higher temperature than outdoor air, and therefore, it is driven through a stack by the buoyancy force. The buoyancy force (driving force) decreases as the difference between indoor and outdoor air temperature decreases. A solar chimney increases the exhaust air temperature, and therefore increases the "driving" force.

The technology

A solar chimney is a kind of solar air collector, and so the general technology is very simple. As mentioned earlier solar chimneys convert solar radiation into air motion. Since air is a transparent medium (radiation-transmitting) it cannot be directly heated by solar radiation. Therefore, a solar chimney has to contain a solar absorber, which enables solar heat to be transferred to the air. There are many possible configurations of a solar chimney. The most common configuration is that utilizing the "greenhouse" effect - an air gap with transparent material (glass) on one side and solar absorber on the other side. The example of such configuration is a double facade, which, in some operation modes, also utilizes the solar chimney principle.

The sensitivity of a solar chimney to wind in terms of backflow is generally the same as the sensitivity of other passive stack ventilation systems. The risk of backflow with regard to wind can be minimized by a proper design of a solar chimney. A backflow in a solar chimney can also occur near cold surfaces due to negative buoyancy. The occurrence of such backflow can be eliminated by thermal insulation.

The driving force depends on the difference between mean air temperature in a solar chimney and outdoor temperature. There is correlation between the solar radiation intensity and the air temperature inside a solar chimney. The decline of driving force, when only indirect solar radiation is available is significant. However, when heat storage is used temporary decline of driving force, when a cloud is going over the sun, can be dampened.

There is a possibility to have a solar chimney assisted with wind catchers for both air supply and air exhaust. A wind scoop enables to catch breeze and supply air into a ventilated space. A small overpressure inside a ventilated space, caused by the wind scoop, would increase the flow rate through a solar chimney. A solar chimney could also be fitted with a kind wind cowl. The problem is a shape of a cross-section of a solar chimney, which is usually rectangular with a high aspect ratio. A contribution of a wind cowl to the solar chimney performance would significantly depend on the wind direction.

General design parameters

It is important to distinguish between the performance of a solar chimney and the performance of a solar chimney ventilation system. The performance of a solar chimney depends on many parameters (configuration of a chimney, geometry of a chimney gap, tilt angle, latitude, sunshine time, etc.). It is possible to optimize a solar chimney to achieve the highest performance for a specific season.

As far as the solar chimney ventilation system goes, a solar chimney contributes to the stack effect created by the difference between indoor and outdoor air temperature. In winter, when the indoor-outdoor temperature difference is high, a contribution of a solar chimney to the overall stack effect is lower than in summer, when this temperature difference is small. It is, therefore, desirable to have the highest performance of a solar chimney in summer.

Feasibility

The main asset of utilization of solar chimneys in ventilation is improvement of the performance of passive stack ventilation on hot sunny days, when there is a small difference between indoor and outdoor air temperature. Solar chimneys used for passive cooling, in countries with hot climate, could avoid mechanical cooling, and therefore to save significant amount of energy.

Even though the principle of solar chimney ventilation has been known for centuries, there are many possibilities how to employ modern technologies in the solar chimney design. One option is to replace glass with semi-transparent photovoltaic cells, which would power a DC fan. Such combination represents a fan assisted natural ventilation system, which could operate without an access to the power grid. The photovoltaic panels, in this case, could also feed a control system, including motorized dampers.

Product information

The solar chimney is usually fitted to the individual build situation and is designed by architects and engineers working on the specific project. Therefore, there is no general product information available at the moment.

3b.4 Wind power

3b.4a Passive : Direct wind augmentation components (EMPA):

- Scoops (augmented intakes) and vanes (augmented exhausts)
 - what is marketability of wind scoops
 - Wind C_p values
- Backflow dampers. can be useful to exploit wind maximally (e.g. www.minergi.se)
 - Is it possible to calculate if air is flowing out or in due to the wind fluctuations at the roof of the building in a vertical stack having a back flow damper (with only 0.2 Pa pressure resistance) at the inlet?
 - the air sometimes seems to stand still in the stack, just pumping.
- What is the pressure difference distribution over facades and roof outlets?
 - different wind climate data
 - effect of local conditions, e.g. different shapes of buildings, wind shielding
 - different leakage distributions

Wind-augmented air exhausts (cowls)

Wind cowls and vanes

During the Photovent project, tests in "real conditions" (on a roof, with variable extracted airflows) have been realised on usual roof cowls spread on the market.



Figure 35 Cowls tested in the Photovent project

These tests have shown that roof cowls that are considered efficient for no airflow (according to the criteria used in France to judge conformity of roof cowls) are not necessary good for "normal conditions" (total extracted airflows from 100 to 400 m³/h), given mainly their high pressure loss (a simple circular duct is often better in case of significant extracted airflows).

In case of locking, the rotating cowl showed a real efficiency decreasing.

A weather-vane type cowl has then been studied



Figure 36 Rotating cowl developed in Photovent project

Tested in the same way as explained before, this cowl showed depression gain until 50% for medium extracted airflows (200 m³/h).

Nevertheless, in case of locking, with wind coming from the back, the efficiency of the vane-cowl becomes very bad. No solutions have been then found to provide acceptable performance in that case

Wind-augmented air intakes

Backflow dampers

Backflow dampers can be installed in stacks and chimneys to prevent backflow of air. It is important that the pressure loss as well as the activating pressure difference is small. Typically the damper is made of poleyten or teflonfolie as it is seen in figure XX. Backflow dampers are available for both circular and square ducts.



Figure XX. Examples of backflow dampers for stacks and chimneys. (www.minergi.se)

Til Peter: I det følgende har jeg forsøgt at besvare spørgsmålet, der er stillet. Svaret er kvalitativt, da jeg ingen pålidelige data har. Konklusionerne er baseret på målinger på solskorstene samt litteratur vedr. modelforsøg i laboratoriet.

The air flow in a vertical stack will depend on the height to width ratio as well as the pressure difference. For large height to width ratios and large pressure differences the air velocities will be high and the air flow will be unidirectional. For small velocities and air flow rates in the stack there is a risk of bidirectional flow. For stacks with a large height to width ratio this will only occur in the top of the stack, but for stacks with small height to width ratios (less than approximately 6-10) cold air can reach the bottom of the stack.

When a backflow damper is activated in the bottom of a stack or chimney all the pressure loss is across the damper. The velocity level in the stack is in theory zero and the warm air in the stack will slowly be replaced by cold outside air. The rate of exchange depends on the stack height to width ratio, with a high exchange rate for a small height to width ratio.

When the wind pressure difference changes the thermal buoyancy of this column of cold air will act in the opposite direction, resulting in a situation where the air in the stack stands still until the change of wind pressure difference is higher than the thermal buoyancy of the cold air column.

The potential risk of this phenomenon depends of stack height, stack height to width ratio as well as frequency and amplitude of wind fluctuations. At the moment it is not possible to

quantify the risk for different configurations. To minimise (avoid) this phenomenon the stack should be well insulated and the backflow damper should be located in the top of the stack.

Wind Cp values

The wind pressure acting on the facade of a building is dependent on wind speed and direction, topography and roughness of the terrain upstream, location of the building relative to other structures or vegetation and building shape. With reference to the static pressure, wind pressure can be determined for individual facade elements with:

$$p_w = C_p \frac{\rho}{2} v_{ref}^2 \quad (12)$$

Several methods are available for the determination of the wind pressure coefficients:

Wall averaged Cp-values for simple building shapes in isolated terrain can be found in literature. For low rise buildings up to three storeys with simple building geometry and uniform surrounding environs, wall averaged Cp-values fulfil with sufficient accuracy the requirements of air flow calculation models. In [Orme 1994] data for different length to width ratios, wind shielding conditions and roof pitch angles can be found. Direction dependence of wind shielding effects is not taken into account. Other sources for wall averaged Cp-values are [Bassett 1990], [ASHRAE 2001].

Tools for the statistical regression of wind tunnel data sets has been developed and can be used in a wider range of application (limits of applicability ?). With Cp-Generator [Knoll 1995], statistical regression of extensive wind tunnel data sets can be performed. Parameters describing the building geometry are used for the regression. With the same method the Cp-values of an upstream obstacle are determined. These values are used together with the distance of the obstacle to calculate a correction term which considers the shielding effect of the obstacle on the Cp-values of the building under investigation.

CPCALC+ [Grosso 1995] is a similar tool. Here the surrounding buildings are described with the two parameters plan area density and surrounding building height. The shielding effect can be taken into account for each calculated wind direction separately.

[Wong 2001] made an evaluation exercise of wind pressure data produced with CPCALC+ and wall averaged values. Data from wind tunnel tests on a scale model of the investigated building including the surrounding buildings are used as reference. Cp-values of the front side facade where compared. A good correlation to the reference values was found for most wind directions. The correlation coefficients of the wall averaged method were slightly closer to 1 than those of the values from CPCALC+.

Specific wind tunnel tests or CFD analysis must be applied for unusual building geometry or specific situations of surrounding structures. Wind pressure coefficients has to be determined for several individual wind directions, usually in regular increments of 30° to 45°. Values for intermediate wind directions can be interpolated from this data.

different wind climate data

Often wind climate data is not measured directly at the building location. Wind data from the nearest meteo station is not in any case useful because the wind speed and direction is very much depending on the surrounding terrain. Only in flat topography the direction can be assumed similar on both locations and the speed can be transferred using the two wind profiles. [WP5_TR]. Hourly weather data sets which are used for dynamic thermal building simulation or solar system simulation are sometimes generated from monthly averaged values using stochastic models. This practise has been proven for air temperature and radiation data, but not for wind data. Therefore hourly measured data should be used.

effect of local conditions, e.g. different shapes of buildings, wind shielding

Shielding effect from surrounding structures must be taken into account for the determination of the wind pressure coefficients. That means wind speed vref at reference height has to be available from a place outside the disturbed area but with the same wind profile.

[Wiren 1985] measured the change in Cp with wind angle and building separation for a building with identical buildings to either side. With flow along the building row and decreasing separation, pressure becomes more uniform for all walls (Cp=-0.15) except the front wall

($C_p=0.15$). It is concluded that only the nearest ring of obstacles dominates the building sheltering, and that additional rings do not significantly contribute to the sheltering effect. Several tables and figures with values for wall averaged C_p 's showing this context are given in [Walker 1993].

3b.4b Active : Indirect wind energy conversion components:

- Local windmills that generate electricity: are these available? what is the potential of small windmills?
- Is this really within the scope of RESHYVENT ? or is only local generation by PV e.g. at the facade to be considered?

Ad will give info on windmills

3c Maximizing primary energy conversion efficiency

Identify possible means of making best use of primary energy, i.e. minimising primary energy conversion loss (low exergy systems)

- low-temperature heating
- district heating & cooling
- Heat pumps (e.g. air-to-air heat pump)
- Derive and develop information about the relation between hybrid ventilation and combined heating and cooling concepts and available products and concepts.

Primary energy will, even after having integrated renewables, deliver a large part of the energy needed by the system. The efficiency and conversion of the primary energy is therefore relevant to the overall concept of developing an energy-conscious ventilation system. The best use of primary energy is of course obtained by working with high efficiencies and low conversion losses. Energy is efficiently used when the quality of the source is matched to the quality demanded by the task i.e. by using the definitions for exergy. Thus, electricity is a thermodynamically sound way to drive a fan but it is not a thermodynamically sound way to heat up a building. It is a waste to use using electricity for space heating, as space heating is a low quality energy task and can be provided more efficiently and cheaper by other means.

Numerous examples exist where the energy source can be matched thermodynamically to the task. For example a ground source heat pump are an excellent way to make use of the low quality heat in the ground to provide for the low quality energy demand of space heating and of not wasting the capacity to perform other tasks that require a high quality energy source. If installed correctly the air-to air heat pumps is also an option. Maximising the primary energy is also done in the combined heat and power (CHP) plants. The CHP's makes use of high quality energy to produce electricity and low quality excess heat to produce domestic hot water and space heating.

4 PERFORMANCE ASSESSMENT

4a Performance assessment (Local or personal impact)

i.e. assessing the environment's impact on man and his property

4a.1 Comfort, health, safety & technical performance

Refer to sources of definitions of air quality, ventilation efficiency (contam-remov-effic. vs. age-of-air concept) – WP5 stuff

4a.1a Principles of performance assessment

This gives important basis knowledge before the software is described. It describes what things one should consider, what precautions & assumptions one makes, and what possibilities there are.

Environmental parameters: Comfort, health & safety

- There shouldn't be too much repetition of standards etc. here - concentrate on the specific issues for hybrid ventilation:
- Differences in acceptable thermal comfort zones for mechanically and for naturally ventilated buildings
 - (For naturally ventilated buildings, the comfort zones follows more the actual outdoor temperature)
 - Different zones for nighttime and for daytime?
- Definitions of occupation zone > critical for draft risk evaluation of outdoor inlets
- Temporal aspects of comfort (Is draft risk instantaneous, thermal comfort in non equilibrium status)
- Acceptable minimum humidity and pollution levels
- It seems logic that users do not expect the same results of different systems: a bicycle is not an airplane. As MV is more automatic/complex/expensive than NV, it seems also logic that users expect more from MV than from NV. This is probably true for IAQ as for thermal comfort. The adaptive comfort theory is based on that idea, which is verified by field analysis (see 2a.2).
- People do not have the same expectation for room temperature during night and time, as their activities (and clothing) are different. In winter, they often reduce the set point temperature during night, in order to reduce energy demand.
- Air inlets create air movements, which can create draught. A good diffuser can reduce that risk, excepted in the zone very closed to it. Therefore (and for thermal comfort reasons too), standards and regulations commonly define "comfort zones" or "occupied zones". The requirements for the indoor environment shall be satisfied in the occupied zone only. prEN 13977 defines a occupied zone:

Table 23 Dimensions for the occupied zone according to prEN 13799

Distance from the inner surface of	Typical range	Default value
Floors (lower boundary)	0.00 to 0.20 m	0.05 m
Floors (upper boundary)	1.30 to 2.00 m	1.80 m
External windows and doors	0.50 to 1.50 m	1.00 m
Radiators	0.50 to 1.50 m	1.00 m
External walls	0.17 to 0.75 m	0.50 m
Internal walls	0.17 to 0.75 m	0.50 m

- Thermal conditions in transient conditions has been much less analysed than in steady-state conditions, even if in real world, the conditions are seldom steady. (Hensen, 1990) has made a review on work on what variations in indoor temperatures may be acceptable to users. Field researches on cyclical fluctuating thermal ambiances tends to show that if the frequency is higher than 1.5 cycles per hour, the maximum peak-to-peak amplitude

should not be higher than 1 K and if the frequency is less than 1.5 cycles per hour, the maximum acceptable peak-to-peak amplitude increases with decreasing frequency, until the steady-state comfort bandwidth is reached. This rule is similar to ASHRAE standard 55-1981 requirements.

Temperature drifts were also analysed, and again the results are similar to ASHRAE recommendations: slow rates of operative temperature change (± 0.6 K/h) are acceptable, provided that temperature does not extend beyond the comfort zone by more than 0.6 K and for longer than 1 h.

The sensitivity is generally found higher during rest than when performing mental work.

Experiments suggest that when operative temperature is inside or near the comfort zone, fluctuations in relative humidity from 20 to 60% do not have an appreciable effect on the thermal comfort of sedentary or slightly active, normally clothed persons.

Fanger concluded that an airflow with high turbulence causes more complaints of draught than an airflow with low turbulence, at the same mean velocity.

However, it appeared from the literature review that different experiences have generated opposite conclusions, mainly with respect to rate of temperature changes, sex and age difference.

- Traditionally, it is stated that humidity should not be outside the range of RH 30% to RH 70%. Therefore, a humidifier could be necessary to maintain these limits during winter in cold/mild climates (at least in office buildings that do not have humidity production, excepted human metabolism). However, some recent studies demonstrated that complains about a too dry indoor air are not only caused by effectively dry air, but also by presence of suspended dusts. In Scandinavian countries (where the supplied air is very well filtered and installations are well maintained), there is a tendency not to humidify indoor air, even when RH is below 30%.
- (The above topics were to be reviewed when considering the outcome of Annex 27 on April 10 2002)
- dynamic modelling of pollutant transport and its effect on occupants
- A more statistical approach on the impact of residential hybrid ventilation in general may be needed.

Dynamic modelling of pollutant transport and its effect on occupants

The transport of pollutants in a multizone building leads to the definition of mass balance differential equations for each pollutant considered, in each zone and at each time step of the simulation period. The main assumption here is that the concentration is well mixed in a zone and is transported from zone to zone by the flow of air. There might be a filter effect in the link due to solid absorption along the path or any kind of reaction (chemical reaction, phase change ...) due to the contact of the pollutant with a solid material. Pollutant sources and reactivity inside the zones are taken into account as well as outside concentrations. Integrating over time and solving these equations leads to the concentrations in each room. The pollutant transport model implemented in COMIS is described in detail in [Feustel 1990] an amendment for layered zones has been made by [Schauwecker 1995]. For the IAQ assessment often the dose of a pollutant is used. Therefore the integral over time of the concentration to which an occupant is exposed has to be evaluated.

A more statistical approach on the impact of residential hybrid ventilation in general may be needed.

In buildings with mechanical ventilation and air conditioning the aim is to keep indoor environmental parameters within certain limits by automatic control to ensure that the majority of occupants find conditions acceptable. In hybrid ventilated buildings, where free floating conditions is utilised to the largest degree possible, the aim is to allow larger variations in the indoor environmental parameters (to save energy), but at the same time to give occupants better possibilities to adjust the system to fulfil their needs (improve perceived IEQ).

Field measurement show that occupants in natural and hybrid ventilated buildings accept – and in fact often prefer – a wider range of temperatures, that more closely reflects the local patterns of outdoor climate change. Probably this will also be the case for other indoor environmental parameters, especially if occupants are provided with possibilities to control their environment.

Another characteristic of hybrid ventilation systems is that the ventilation capacity can change quite rapidly as a function of time primarily due to changes in wind conditions. This means that indoor environmental conditions also will change and for short (or longer) periods exceed the limits set for the IEQ. Field experiments in hybrid ventilated buildings show that occupants do accept these variations. However, only very limited and unstructured information exists on how often and for how long periods such indoor environmental "peaks" are acceptable.

Therefore, for performance assessment of hybrid ventilation systems there is a need for new targets for IEQ based on a more statistical approach. At the moment the indoor temperature is the only indoor environmental parameter, where a statistical approach is taken into consideration in national recommendations. In several countries the indoor temperature limit depends on the outdoor temperature, it is accepted to exceed the limit for a certain number of hours (or degree-hours) and an absolute threshold value is defined. Comparable recommendations are necessary for other indoor environmental parameters like CO₂-concentration, air velocity, ect.

However, to get full value of a more statistical approach the performance prediction must also be elaborated and all indoor environmental parameters must be predicted on a hourly basis for a full year. This puts new requirements to the level of performance assessment, to input data like occupant behaviour and to prediction of the dynamic response of the building to changes in humidity, pollution levels, ect.

Urban impact

Assess the impact of the various urban characteristics (e.g. traffic, heat island, urban canyons) on system's efficiency: These questions can't necessarily be answered already in the state of the art report, but at least a state-of-the-art literature review:

- reduced wind effect
- increased pollutant concentrations
- higher maximum air temperatures, shift in time of maximum temperatures -> affects cooling demand
- glare, solar shading from surrounding buildings
- Q: Should we rate individual streets in a built-up area according to suitability for hybrid ventilation? (according to wind direction and speed and deposition of pollutants)
- Q: Do we need a map of prevailing wind directions to assess suitability of hybrid ventilation in different locations in a particular street?

System performance (energy & technical)

- define exergy, energy performance (EP), etc.
- The problem here is that the energy use assessment of a building cannot be handled just for the ventilation system alone.
 - If e.g. a wood furnace is used for heating, then this system is quite CO₂ neutral (about 90%, depending on transport of wood) and thus ventilation losses have a much smaller impact and thus much smaller importance as if the house is heated by a gas boiler.
- What about standards & regulations for energy performance, EP
- What results and available knowledge are there of other relevant EU studies focusing on component optimisation? (SAVEDUCT, TIPVENT)
- Ductwork design: principles
- What is the optimum pressure drop on the "pressure-drop spectrum" for ventilation systems; how to find this out?
- Reliability assessment principles (Annex 27)
- Message that you need to simulate controls : time steps etc.

Buildings are complex thermal systems. Ventilation air interacts with other building loads, and it can add to the building load or decrease it, according to conditions. E.g., when heating is needed and the outdoor temperature is low, both loads can be added, but when the building heating load is negative due to availability of high solar gains, the ventilation load will have an

opposite contribution. During periods with overheating, cool outdoor air, if available, can provide “free-cooling”. It is also possible to interact with the building fabric and store energy (heating or cooling the thermal mass, as desirable), on a dynamic basis. Therefore, to evaluate the overall impact of ventilation, it is necessary to perform a global energy analysis of the building, as analysis of ventilation alone will result in erroneous conclusions.

The optimum control of the ventilation system also depends on the interaction with the building. E.g., if the system has the possibility of heat recovery, controls should allow for bypassing the heat recovery device when the overall building load so requires, not by just looking at the ventilation load by itself (e.g., during free-cooling situations, a pure ventilation control would detect cold air outside relative to indoors, and activate heat recovery, but the best strategy would exactly be the opposite, to allow ventilation to contribute for the reduction of overheating).

Results and available knowledge – other EU projects:

TIP-vent

The main aim of the TIP-Vent project was to provide a substantial contribution to the creation of improved boundary conditions for the application of mechanical ventilation systems with good levels of performance. The TIP-Vent project has led to a better understanding of the true performance of ventilation systems, why they perform as they do and what improvements are achievable. One major conclusion is that ventilation systems often perform very badly in terms of energy efficiency, indoor air quality, draughts and noise levels. Three innovative products have been developed within the project:

- An active noise attenuator
- A set of components for low-energy ventilation systems
- A booster intake valve for predictable ventilation requirements

SAVE-DUCT

The project was focused on the improvement of the ductworks. Duct leakage is detrimental to energy efficiency, comfort effectiveness, indoor air quality, and sometimes even to health.

In most countries designers, installers, building managers and building owners, ignore the benefits of airtight duct systems. Simple analyses on specific cases can be made to show that the overall performance of the systems is drastically affected when the ducts are leaky. The projections at the European level, based on available measurement data, suggest potentially large energy impacts of duct leakage. However, it is possible and easy to install tight duct systems with quality commercially-available products. In Sweden, where factory-fitted sealing gaskets are widely used, airtightness Class C is commonly required and fulfilled. Furthermore, the additional investment cost (if any) for these products is probably not very significant since the labor cost is considerably reduced. In addition, the duct systems installed today are likely to be used for at least the next twenty to fifty years. A possibly higher investment cost for a higher quality duct system should be considered on a Life Cycle Cost (LCC) basis.

Reliability assessment

The reliability of a ventilation system means the probability that it performs in an acceptable way. Of real concern is the reliability of achieving good indoor air quality. Within Annex 27 [Månson 2002] two different tools have been developed, which can be used to assess the reliability of different residential ventilation systems. With the first one, the reliability indicated by air flow rate stability as a function of a number of factors and with the second the reliability indicated by performance over time i.e. systems and components reliability can be assessed.

Flow rate stability can be expressed as the fraction of time when the ventilation air flow rate is at or above a certain requirement. The influence of the system type, climate, dwelling type, air leakage, inlet area and the existence of an extra fan on the flow rate stability can be assessed with the annex 27 tool.

Reliability as indicated by performance over time is dependent on the technical quality standard of the system and its components, the maintenance level, the dwelling type (apartment or single family house) and the ventilation system type. The evaluation of the system reliability is based on the life time of each component of the system. The life time can be modelled with a normal probability distribution described with a mean life time and a standard deviation. After each maintenance interval the component is assumed “as good as

new” in the model. By connecting the component models in a fault-tree scheme the model can be extended to a system level.

4a.1b Software/tools

This section suggests specific tools, with references, giving for each: pros/cons, applications, required skill level, etc. Also gives advice & tips on use.

Overview

A rough overview of applicable models for air infiltration and ventilation calculations is given in table xx according [Orme 1999] where they are described in more detail The models can be divided in single and multi-zone models. In single zone models the internal air is assumed to be a single uniform temperature. They can be configured quickly and the numerical solution procedures are also able to operate quickly. However, this speed of use and operation is at the expense of the detail, which is fairly crude. Multi-zone models allow the division of the building into separate zones, which may be at internal pressures and temperatures distinct from one another. Their solution can provide detailed results about the mass flow rates through all airflow paths. Both, single and multi-zone models depend on mass balance of the air flows through the building

Table 24 Overview of applicable models for air infiltration and ventilation calculations according [Orme 1999]

	AIDA	AIM-2	AIOLOS	BREEZE	CEN	CIBSE	COMIS	COMTAM W2	LBL	NATVENT	NAVIAG	NiteCool	PASSPORT Plus	Summer Building	Summer Techniques	VENT
Simplified		•			(•)	•			•	•	•	•		•		•
Single zone	•	•			•	•			•	•		•		•		•
Multi-zone			•	•			•	•			•		•		•	
Air flow component database							•	•								
Air flow component types																
- Cracks (power law, opening area...)	•	•	•	•	•	•	•	•	•	•		•	•	•	•	•
- Two way flow in large openings			•	•		•	•	•					•		•	
- Air handling system (ducts, fittings, fans...)				(•)			•	•								
- Fixed flow	•				•							•	•			•
Default Cp values		(•)			(•)				(•)	(•)	(•)					
- Database			•									•				
- Calculated			•													
Pollutant generation schedules				(•)			•	•			(•)					
Occupancy schedules							•	•		•		(•)	•			
Air flow component schedules			•	(•)			•	•			•	•	•	•	•	•
Meteorological data input files			•	(•)			•	•		•			•	•	•	
User interface																
- Paper based		•			•	•			•							
- ASCII-text input file							•									
- Menu			•							•	•	•	•	•	•	•
- Graphical				•			•	•								
- Spreadsheet	•						•									
Output format:																
- Numerical	•	•	•	•	•		•	•	•			•	•	•	•	•
- Graphical			•	•			•	•		•	•	•		•	•	
Availability:																
- Public domain	•	•			•	•	3.0•	•	•							•
- Comercial			•	•			3.1•			•		•	•	•	•	

Simple tools for indoor environmental parameters and energy use :

- Annex 27 tool and other similar basic tools for IAQ, thermal comfort, noise, etc.

- Simple energy modelling methods & software: EN 832 etc, Annex 27, TIPVENT. Other EP-methods used?

Advanced modelling methods & software for indoor air distribution :

- Multizone: COMIS, IDA, ESPr?
- CFD: external & internal airflow applications

Multizone modelling

Multizone air flow models such as COMIS, CONTAMW2, ESP-r idealize the building as a network of nodes and airflow links. A node represents a room volume which a set of state variables can be assigned to. Cracks, window joints and openings, shafts as well as ventilation components like inlets and outlets, ducts and fans represent the links.

Boundary conditions and thereby also input factors are:

- State variables of the air in the zones
- Local wind pressures

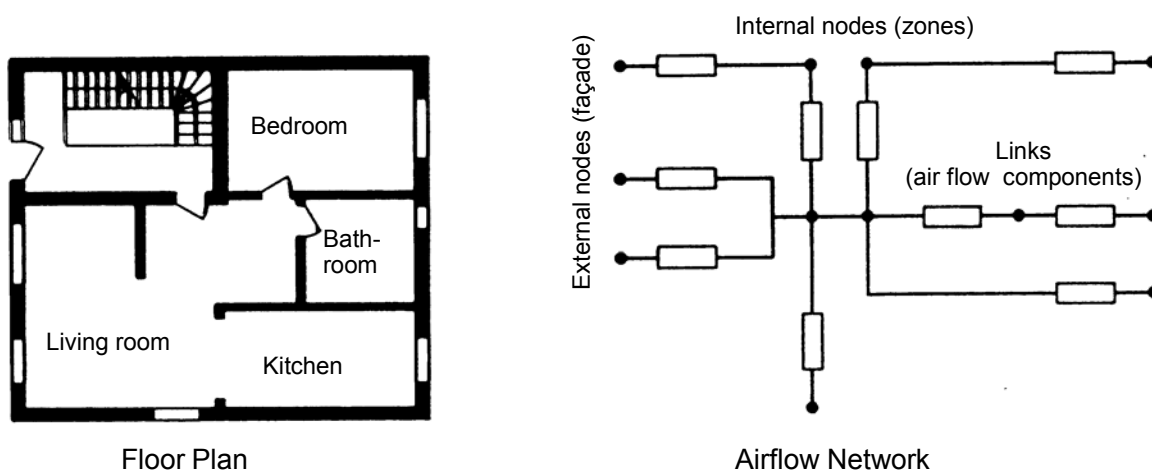

Figure 37 Modelling of a building as air flow network with zones and links

The pressure p_z is a free parameter in the node which is evaluated according to the continuity equation (mass flow balance in the node = 0). This results in n_z equations where n_z represents the number of zones.

The relation between mass flow rate m and pressure difference Δp and thus the zone pressure p_z is not linear. Therefore an iterative process is used to solve the system of equations. The mass flow rates per link and all dependent factors such as air exchange rates, air age etc. are calculated of the resulting zone pressures $p_{z,i}$. The calculation is static without an explicit consideration of the time step. In principle calculating a condition based on a new time is independent of the previous time step.

Advanced integrated (whole building) modelling methods & software for indoor environment & energy etc. :

- TRNSYS-COMIS, EnergyStar, ESPr: General intro to software with this capability, Ways of coupling
- State of the art specific to Control, is handled in WP7, but a short review mentioned here ?

TRNSYS-COMIS, EnergyStar, ESP-r, General intro to software with this capability. Ways of coupling

The indoor temperatures are important boundary conditions of a multi zone air flow model which mostly can only be defined on the basis of the user`s guess. On the other side indoor air temperatures calculated by a thermal model strongly depends on the air flows within the building. Combined modeling of energy and mass transport is the obvious consequence. This

can be done by linking the two models and mutually use the results. Three approaches to do this has been described in [Hensen 1995]. In the simplest method, known as "sequential coupling", the mass flow rates are calculated first, with assumed internal temperatures, and these values are then fed into the thermal model. There is no feedback from the thermal model to the ventilation model. In the so called "ping-pong" approach the calculated air temperatures are fed back into the ventilation model at the next time step. The last method is known as "onions" approach. Here the feedback between both models takes place at the same time step and is repeated until convergence is reached. [Smith Schneider 1995] described a direct strategy to solve the thermal and the air flow equations simultaneously.

In several thermal building simulation programs (EnergyPlus, TRNSYS, ESP-r) an air flow model has been integrated and a coupling with the thermal model has been realised using the "onions" strategy. [Crawley 1999], [Dorer 1994], [Weber 2003], [Hensen 1995]

State of the art specific to Control, is handled in WP7, but a short review mentioned here ?

In hybrid ventilation there is a strong relation between the control strategy used and the actual performance of the ventilation system in relation to indoor climate, energy consumption and costs. Therefore the used simulation tool should be able to model the control strategy. In the IEA ECBCS Annex 35 HybVent four different simulation tools (CHEMIX, SPARK, HYBCELL and COMIS+TRNSYS) were used to model different ventilation systems with different control strategies [Delsante 2002]. The conclusion was:

It is possible to use coupled thermal and air flow simulation tools to evaluate systems and control strategies. The used tools were able to handle a mixture of time, temperature and CO₂-based control and were able to implement the short time step needed for a realistic simulation. But great care is needed when using these tools. In terms of relative performance, the tools were most consistent with respect to CO₂. They were less consistent with respect to heating energy, possibly because of different implementations of the heating controller. Small differences between two systems or control strategies should not be given too much weight, as the use of an other tool could easily predict a change in opposite direction

Optimisation/probabilistic assessment methods :

- Models of occupant behaviour
- Monte Carlo with COMIS or DOE EnergyStar
 - data for such stochastic modelling (apart from the occupant behaviour models above)
- Annex 27 reliability tool

Annex 27 reliability tool

See above Reliability assessment

A deterministic approach implies that all input parameters and model coefficients are 100% certain with zero spread. In practice, this is not the case: for example inhabitant behaviour and internal loads may vary significantly and external loads such as wind, external temperature and solar radiation are obviously stochastic in nature. One reason for ignoring randomness is the fact that mechanically ventilated heavy buildings are often highly "damped" and shielded from external loads. These kinds of buildings will also control the influence of the internal load effectively by means of the building energy management system and the HVAC system. However, lighter constructions that are naturally or hybrid ventilated are more sensitive to stochastic load variations.

The advantage of probabilistic methods is the possibility of not only designing for peak load and estimating annual energy consumption based on a reference year, but also to examine the range of variation and quantify the uncertainty. Probabilistic methods can be used as a tool to evaluate the trade-off between economy (cost, energy and environment) and risk (expectations not met, violation of regulations, etc.) on a firm foundation. It allows a more courageous design, which may in turn result in increased user satisfaction, energy savings and "greener" buildings due to the fact that the uncertainty can be calculated and not just assumed roughly. For instance, a building owner can prescribe the probability allowed for a certain parameter to exceed the bounds of a design interval.

The Monte Carlo Simulation technique is one of the simple probabilistic methods, where a statistical description of model output is obtained by multiple simulations with different model input. Some or all of the input parameters are modelled either as random variables or stochastic processes, described by statistics, i.e. mean values, standard deviations, auto-

correlation functions, etc. and the results are the corresponding statistics of the output. A stochastic method is thus a formulation of a physical problem, where the randomness of the parameters is taken into account. In principle, any of the above-mentioned methods like DOE Energy Star, Comis and ESP-r can be applied.

The input parameters are modelled by time varying mean and standard deviation functions and the underlying distributions functions. The functions for external loads can be determined from design reference year weather data by means of FFT (Fast Fourier Transform) analysis. Both temporal as well as mutual dependence between the different loads can be modelled by means of auto- and cross-correlation functions. The Nataf transformation can be used to generate a vector of discretised random variables, whose components include all external load and other parameters (input) at a number of points in time. This is done by mapping between the random vector and independent standard normal variables. The standard normal variables can be simulated on the computer by a random number generator.

For each simulated input time series, the model provides corresponding output time series, like air flow rate and control parameters. Finally, the statistics of the output, i.e. mean values, standard deviations and distribution functions, are obtained by statistical analysis of the simulated time series.

In Annex 35 the application of the Monte Carlo method is demonstrated for a single zone hybrid ventilated building model.

Specialised systems simulation software

- e.g. PVS : commercial PV modeller. Also TRNSYS (thermal systems), SimCAD (controls)
- Ductwork design tools; pressure drop calculations
- Controls simulation : Simulink

Design software for ductwork

There are many kinds of software in Europe on the market to design ductwork.

I can only give an example of the software we use in our company.

We have two:

First is an application on Autocad called Nordined.

- It is possible to choose yourself a diameter of ducting and draw it. It depends on the engineer to design a ductwork with low pressure.
- Also it is possible to let the program calculate the ductwork by given it the amount of air and the place of the grilles. The parameter you give to the program is the airspeed in the ductwork you want. The program calculates the diameter of the duct.

The other one we have is VABI.

This program has more intelligence. Given the ductwork layout, it will calculate the diameter.

The input you give can be various.

- The wanted pressure loss in the ductwork. (the program will calculate the diameter by the given air quantity.
- The wanted airspeed in the whole ductwork or in specified branches.
- The type of material you use, it is important for the wall smoothness of the duct.
- The diameters you want to use and those you don't want to use.
- You can choose the airspeed so, that in the whole ductwork the airspeed is the same.

Software tools available for PV simulation

- PVS for Windows (Fraunhofer Institute for Solar Energy Systems - Germany)
- PV SYST (CUEPE / University of Geneva – Switzerland)

- PV F-Chart (F-Chart Software)
- PV*Sol (Dr. Valentin Energie Software GmbH – Germany)

Software tools available for solar preheating simulation

- TRNSYS (thermal systems, fluids)
- TRNSAIR for windows 95/ NT(thermal Solar air systems) (Transsolar energietechnik GmbH - Germany)
- SimCAD (controls)
- THERM (two dimensional heat flow)

4a.2 Financial assessment

4a.2a Principles of financial assessment

- Short general intro to LCC
- LCC of hybrid systems needs attention, and is an issue
 - What is the state-of-art? Existing sources of costing data, lifetime
 - What is the starting point for RESHYVENT ?

Life cycle costs LCC - introduction

It is easily understood that the total cost of a product through its life cycle comprises not only acquisition costs, but also many other cost categories (operation costs, maintenance costs, logistics costs, etc). Life Cycle Costs are the total costs estimated to be incurred in the design, development, production, operation, maintenance, support, and final deposition of a major system over its anticipated useful life span. The ownership costs are very often higher than the acquisition costs. It is believed that a typical range of the ownership costs is 60% to 80% of the total LCC. The LCC costs are found by an analytical study of total costs experienced during the life of the equipment or project. The objective of the LCC analysis is to choose the most cost effective approach from a series of alternatives, so as the lowest long-term cost was achieved. If we do not care about the ownership costs at purchasing a product, it is likely that we get surprised by the growing ownership costs after the purchase. It is consequently important to minimize the LCC in early phase of the product life cycle. The implications of the acquisition costs for the LCC can be, in other words, expressed - "It's unwise to pay much, but it's foolish to spend too little..."

4a.2b Software/tools for financial assessment

methods/standards/tools for LCC and investment profitability, e.g. simple Annex-27 LCA tool. Which tools can be used for hybrid systems; any other limitations?

Analysis of the capabilities of the best well-known packages showed that no single package seemed to solve all the required facilities:

- ESP-r, a simulation European simulation tool, is especially good for simulating the building envelope and calculating global energy consumption and indoor air quality indicators, it offers the capability to simulate airflows by the detailed network resistance method, and it is possible to simulate controls. But ESP-r is not very flexible towards the simulation of the details of the ventilation systems that are one of the basic goals of this tool.
- DOE2, an American software package, is a little better than ESP-r for the simulation of HVAC components, but it lacks the capabilities to simulate airflows in detail and it is being discontinued by its authors in favour of an yet unavailable newer alternative. It was thus felt that DOE2 would be an inappropriate choice.
- TRNSYS offered quite good capabilities in terms of most of the capabilities needed, as detailed in the list above, except for the possibility for detailed modeling of airflows.
- COMIS is a specialized software tool devoted to modeling airflows in as much detail as desirable, including all the details of the ventilation system components.

Therefore, the chosen simulation program was TRNSYS and COMIS working together. These two programs together offered all the needed capabilities and there was prior experience by various teams of linking them together, as reported in the literature. Moreover, it became known that TRANSSOLAR, the EU distributor of TRNSYS, and EMPA, a RESHYVENT partner,

were working on a user-friendly interface to link the two software packages together. IDMEC thus signed a beta test license agreement protocol with them, which will allow the use of the graphic interface tool TRNFLOW in the final RESHYVENT tool, once both are completed by the end of the project.

4b Environmental assessment (Global/regional societal impact)

i.e. assessing man's impact on the environment (which in turn affects sustainability)

4b.1 Principles of environmental assessment

4b.1a Life cycle assessment

LCA of materials, building construction & building services, impact of primary energy use, and waste.

- Specific environmental impacts of dwellings, and especially ventilation:
 - Carbon Performance Rating (CPR) for dwellings
 - Ozone layer depletion potential
- There are also integral parameters which aggregate the individual impacts into one single parameter

4b.1b other assessment methods ?

- These questions are addressed in WP5 and/or WP6, but maybe a short state-of-the-art review can be given here ?

4b.2 Software/tools

There are LCA tools for ecobalance, ecological evaluation or environmental impact studies of buildings available

- e.g. OGIP (see www.ogip.ch , site in German only)
- Integral parameter tools: Ecoprofile (NO), EcoIndicator, BREEAM (UK), ECOQUANTUM (NL)
- Such tools focus more on building materials than on the HVAC system of a building.
- But these tools are useful to compare impact of energies used. Environmental impact figures e.g. for PV panels, batteries etc.

Research efforts and national energy policies have encouraged energy conservation and renewable energy technologies successfully, allowing the reduction of specific end-energy consumption. Since the oil crisis, the general objective of energy saving has shifted from the shortage issue to a more general objective of environmental protection. There is a need for scientific methods to assess the environmental impact of a building allowing one to choose among different low energy and solar technologies. The inventory of mass and energy flows during the life cycle of a product is one generally accepted basis for the environmental impact evaluation.

Some of existing methods including labels, declarations of content, positive and negative lists, and qualitative appreciations are not transparent and they are often only suited for a limited part of the design and building process. They furthermore do not include a life cycle perspective.

Many others and/or upgrades of several combine several areas of application within a single unique tool. These are e.g. life cycle engineering, life cycle assessment, analysis of energy and material flows, design for environment and provides

support for environmental management systems. Furthermore they offer a cost functionality for the economic analysis of systems and processes. Within several of the tools there are data bases including ecoprofiles on e.g. aluminium, steel and iron, polymers, non-iron metals, to allow performing a professional environmental management.

The method of Life cycle assessment (LCA) has been widely accepted by industry and standardization boards (ISO). The complete LCA method has 5 steps – see Tab.1. The steps «classification» and «evaluation» are called Life cycle impact assessment (LCIA).

Table 25 *Life Cycle Assessment (LCA)*

<ul style="list-style-type: none"> • Goal definition • Inventories • Classification • Evaluation • Improvement 	}	life cycle impact assessment (LCIA)
---	---	-------------------------------------

LCA had to be adapted to the building industry from tools aimed mainly at industrial products with current life times of weeks and months. Buildings are produced as one-of-a-kind products, their lifetime may be up to hundreds of years, they include a large and still growing number of materials, and their design process is complex involving many actors with often contradicting targets. LCA for buildings had to define limits in time and in space and to develop models for the simulation of the life cycle (maintenance, refurbishment). Specific functional units (adapted to the different steps in planning from design brief through the design and construction process to facility management) also had to be defined. LCA Phases for buildings can be defined as follows in Figure 38.

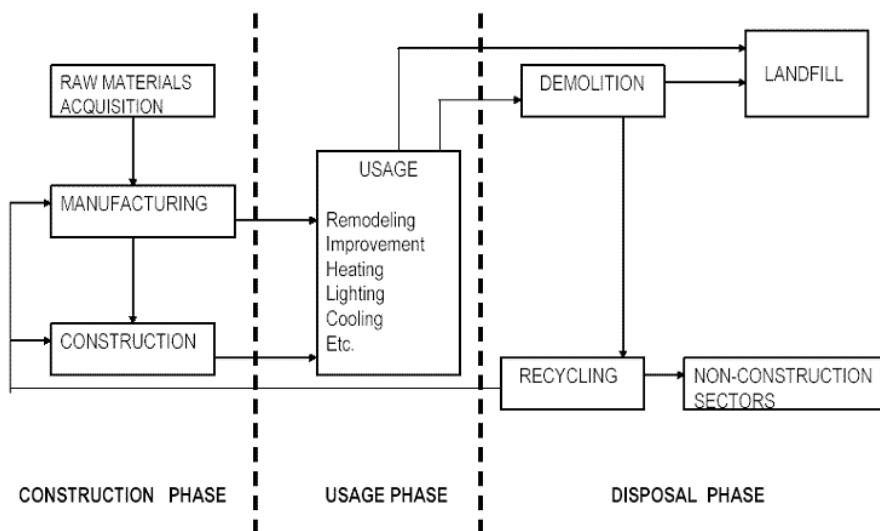

Figure 38 *Illustration of LCA phases*

LCA provides a scientific base in the construction field. There are however still many open questions for research : What are the correlations between the existing and new evaluation criteria, do multicriteria methods allow one to handle the complexity of several evaluation criteria, what are the transfer functions for waste, how to integrate the resource consumption and possible recycling, how to appreciate the impact on the local environment (town and regional planning), indoor air pollution (sick building syndrome), worker protection, user protection during refurbishment. This research effort will only be successful if it is based on a close collaboration of industry, research institutions and designers.

The design process of buildings is not linear. Design tools for LCA must be tailored to the main steps in the decision process. The question in the design brief is : do we need a new building or can we transform an existing building. In the building design the question are how does a design alternative relate to functional performance, costs, energy consumption and environmental impact. In the construction stage the optimal choice of building materials and building processes in relation to the ecotoxicological and humantoxiological requirements are critical. At the same time the functional unit varies from very general m² use surface to detailed building specification (pouring 1 m³ of concrete).

LCA is closely connected with sustainable construction. Sustainability is the issue of our time. In addition to the environmental and social benefits, the business benefits of operating sustainably are increasingly apparent. Some of the LCA tools will help to assess and reduce environmental impacts and associated costs, and comply with existing and proposed legislation.

Information on many of LCA tools can be found on specialised WEB pages:

- [Building Research Establishment Ltd \(BRE\)](#)
- [Chalmers University of Technology](#)
- [ifu Hamburg Ltd. - ifeu Heidelberg Ltd.](#)
- [LG-PRC](#)
- [PE Europe GmbH](#)
- [PRé Consultants BV](#)
- [The ATHENA Sustainable Materials Institute](#)
- [TNO Industrial Technology](#)

5 FURTHER READING : A LIST OF SOURCES

A thematic list of sources on R&D projects relevant for RESHYVENT could be helpful.

The list includes reports, papers, books, CD-ROMs, and weblinks.

- Ajiboye P. (1998): Ventilation technologies in urban areas – A Simple Interactive Design Tool for Sizing, Locating and determining Pollution Attenuation features, of Urban Air Inlets suitable for Office Buildings, 19th annual AIVC conference [📄](#)
- ASHRAE (1997): Fundamentals Handbook (SI), American Society of Heating Refrigeration and Air Conditioning Engineers, (Wilson 1995)
- ASHRAE (2001): ASHRAE Handbook Fundamentals (SI), ASHRAE Atlanta
- ASHRAE (2001): Fundamentals Handbook (SI)
- Basset M. (1990): Infiltration and leakage paths in single family houses- a multizone infiltration case study, AIVC Technical Note 27
- Bluyssen, P.M., Oliveira Fernandes, E., Molina, J.L (2000), Database for sources of pollution for healthy and comfortable indoor environment (SOPHIE): Status 2000, Healthy Buildings 2000. Espoo (Finland). Materials, Design and Construction. Pp. 385-390. 2000.
- Crawley D.B. et al. (1999) Energyplus a New-Generation Building Energy Simulation Program, U.S. Departement of Energy (1999)
- Delsante A., Aggerholm S. (2002) The Use of Simulation tools to evaluate Hybrid ventilation Control Strategies, IEA ECBCS ANNEX 35 HybVent technical report.
- Demeester J. (1998): Best practice when installing air inlets to buildings situated in an urban environment, a design tool, NatVent [📄](#)
- Dorer V., Weber A. (1999), Air contaminant and heat transport models: integration and application, Energy and Buildings Vol 30 (1999) 97-104
- ECA (1996) European Collaboration Action: Indoor Air Quality & its Impact of Man, Report No 17: Indoor Air Quality and Use of Energy in Buildings, Report EUR 16377 EN 1996
- Fanger P.O., Thermal Comfort: analysis and applications in environmental engineering, McGraw-Hill, New-York 1972
- Feustel H. et al. (1990), Fundamentals of the Multizone Air Flow Model COMIS, AIVC TN 29
- FiSIAQ (2000) Classification of indoor climate 2000, Finnish Society of Indoor Air and Climate
- Grosso M. (1995): CPCALC+, Calculation of wind pressure coefficients on buildings, Software from Polytechnic University of Turin
- Hensen J (1995), Modelling Coupled Heat and Air Flow: Ping.Pong Vs. Onions, 16th AIVC Conference 1995
- Hensen J.L.M., Literature Review on Thermal Comfort in Transient Conditions, in Buildings and Environment Vol 25 n°4, UK 1990 (AIVC #4595)
- IEA (2005), Handbook: Guide to Cost Effective Design, IEA SHC Task 28 / ECBCS Annex 38: Sustainable Solar Housing, to be published in 2005
- ISIAQ (2002) Performance Criteria of Buildings for Health and Comfort, ISIAQ-CIB Task Group TG 42 Draft June 2002, **may not be quoted !**
- ISO 7730, Moderate Thermal Environments - Determination of the PMV and PPD indices and specification of the conditions for thermal comfort, 1994
- Knoll B. (1996): CpGenerator, Software from TNO
- Knoll B., Phaff J.C., de Gids W.F. (1995): Pressure Simulation Program, 16th AIVC Conference, Palm Springs, USA
- Koschenz M., Lehman B. (2000): Thermoaktive Bauteilsysteme tabs, EMPA july 2002
- Kosonen R. (2002): Displacement ventilation for room air moisture control in hot and humid climate, Roomvent 2002 Paper 241
- Liddament M. W. (1996): A Guide to Energy Efficient Ventilation, Annex V [📄](#)
- Limb M J. (1994): Garage ventilation: an annotated bibliography, AIVC.
- Limb M J. (1995): Air intake positioning to avoid contamination of ventilation – an annotated bibliography, AIVC.
- Lumme P., Merikallio, T. (1999) The water and moisture control plan of the construction site , Sisäilmastoseminaari 17.-18.1999. SIY Raportti 13, 29-32, Helsinki. in Finnish

- Månson L.G. (2002) IEA ECBCS Annex 27 Handbook, Evaluation and Demonstration of Domestic Ventilation Systems, FaberMaunsell Ltd 2002
- Martin A. (1995): Control of natural ventilation, BSRIA TN11/95, Bracknell
- Martin A. (1996): Night cooling control strategies, BSRIA Report 11621/4, Bracknell march 1996
- NatVent (1999): Natural ventilation for offices, BRE on behalf of the NatVent consortium.
- Orme M. (2002): Ventilation modelling data guide, AIVC Guide 5, INIVE on behalf of the IEA
- Orme M., Liddament M, Wilson A. (1994): An Analysis and Data Summary of AIVC's Numerical Database, AIVC Technical Note 44
- P.J.M. Op't Veld, Noise aspects of ventilation systems in dwellings, IEA ANNEX 27, February 1994.
- prEN 13799, Ventilation for non-residential buildings – Performance requirements for ventilation and room conditioning systems, October 2001
- Santamouris M. et al., Energy and climate in the urban environment, James and James (Science Publishers) LTD, London (2001).
- Schauwecker R., Dorer V., (1995), Modification of the pollutant transport routines in COMIS, IEA-ECBCS Annex 23
- Sprenger E., Hönemann W (2001): Taschenbuch für Heizung und Klimatechnik, 68. edition, Oldenburgverlag München, Wien
- Walker I.S. (1993): Pressure Coefficients on Sheltered Buildings, AIVC AIR Vol.13 No.4 1992
- Weber A. (2003), TRNFlow, a new tool for the modelling of heat, air and pollutant transport in buildings with TRNSYS, IBPSA Conference Building Simulation 2003 Will be submitted until February 15th
- Wirén B-G. (1985) Effects of surrounding buildings on wind pressure distributions and ventilation losses for single-family houses, Part 1: 1 ½ -storey detached houses, Part 2: 2-Storey terrace houses, The national Swedish institute for building research, Gävle, Sweden 1985/87
- Wong N.H., Chin H.K (2002): An evaluation exercise of a wind pressure distribution model, Energy & Building, 34 p 291-309
- WP5 –WR2, Performance criteria and target levels, Design constraints, Building and ventilation system design variables; RESHYVENT-WP5-WR-2.Version 6 24 Jan 2003
- WP5_TR, WP 5 Technical report, RESHYVENT-WP5-TR-5-V2
- Heiselberg, P. (ed.), Principles of Hybrid Ventilation, IEA-ECBCS Annex 35, August 2002
- Delmotte, Chr., TipVent Source Book, EU project Tipvent, BBRI, 2001
- Carre, F.R , Andersson, J. and Wouters , P., Improving Ductwork, EU project Save Duct, AIVC, Coventry , 1999
- Mansson, L.G.M., Simplified tools for Evaluation of domestic ventilation systems, Handbook, IEA-ECBCS Annex 27, August 1998
- Recknagel, Sprenger en Schramek, Taschenbuch für Heizung und Klimatechnik, 69 Auflage, Oldenburg Verlag, Munchen 1999
- Dubrul, C., Inhabitant Behaviour with respect to Ventilation, AIVC TN 23, Bracknell, March 1988
- Solar air systems – A Design Hand book, by S. Robert Hastings and Ove Mørck, 2000 (James and James).
- Solar Energy in Building Renovation, by Dalenbäck J-O, 1996.
- IEA Solar renovation Concepts and Systems. A report of Task 20 Subtask F. Improvements of Solar Renovation Concepts and Systems. Nov. 1999.
- BPS Luftsolvvarmeanlæg 133. Maj 2000
- De Dear, R.J. and Brager, G.S. 1998. Developing an adaptive model of thermal comfort and preference. ASHRAE Transactions, Vol. 104, Part 1.
- Books on renewables:
- ◇ Stand Alone Photovoltaic Applications (James & James)
 - ◇ Examples of Stand-alone photovoltaic systems
 - ◇ Solar air systems – A Design Hand book, by S. Robert Hastings and Ove Mørck, 2000 (James and James)
 - ◇ Solar energy in Building renovation, by Dalenbäck J-O, 1996.