Developments in Noise Control

A.C.C. Warnock

Contents

<i>Sound Transmission through Block Walls</i>	48
Background – Transmission Loss (TL) and Sound Transmission Class (STC)	48
Increasing the STC of Block Walls	49
Summary of Findings and Recommendations	51
<i>Plumbing Noise</i>	52
Resilient Wrappings	52
Wall System Modifications	53
Combined Approach	53
Comparison of Pipe Materials	54
Conclusions	54
<i>Flanking Noise</i>	54
<i>Noise Leaks</i>	55
Electrical and Other Wiring Outlets	55
Partitions and Ceiling Spaces	56
<i>Summary</i>	58
<i>References</i>	58

Unless requirements are laid out in codes, control of noise in buildings is often an afterthought. The measures taken to control noise, however, are invariably linked to other building subsystems. Mechanical and plumbing subsystems generate noise; the design of walls, ceilings and floors affects sound transmission.

This paper addresses four topics:

- sound transmission through concrete blocks
- plumbing noise
- flanking noise
- noise leaks.

It assumes a certain background in acoustics and will explain briefly only those terms and ideas relevant to the topics under discussion. Readers not familiar with some of the basics of noise control are referred to BSI '85 Noise Control in Buildings¹ and the CMHC publication Noise Control,² authored by IRC research officers.

Sound Transmission through Block Walls

Background – Transmission Loss (TL) and Sound Transmission Class (STC)

Transmission loss (TL) is the loss in sound power that results when sound travels through a partition. The more power that is lost, the greater the TL. Figure 1 shows sound transmission loss values for some common materials. For single layers of common materials, TL values range from about 10 to about 80 dB.

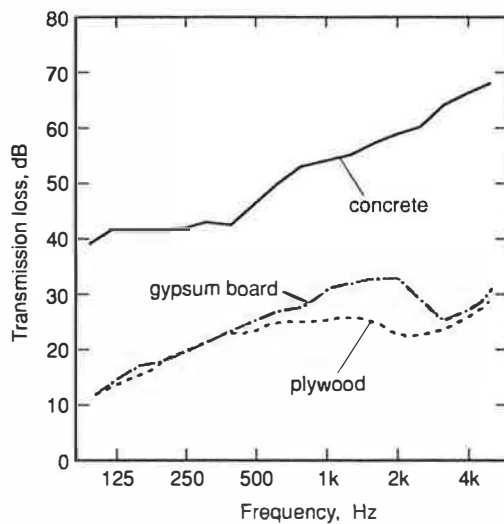

Figure 1 Sound transmission loss through building materials

TL depends on frequency; it generally increases as frequency increases. Low frequencies pass through walls much more easily than high frequencies. That is why bass guitar and drum sounds from adjacent apartments are usually most prominent; they are mostly low frequency. HVAC systems may also contain a great deal of low frequency sound.

The smallest difference that people can detect easily is about 3 dB. There is little point therefore in worrying about TL changes of one or two dB.

TL plots for building materials present too much information to be easily assimilated. It is more common to use the sound transmission class (STC). STC is a single number rating that summarizes airborne sound

transmission loss data. Figure 2 shows the STC contour fitted to the TL curve for concrete block. Once the fit is carried out according to the rules laid down in the ASTM standard,³ the STC value is read from the reference contour at 500 Hz. The higher the rating, the more sound is blocked.

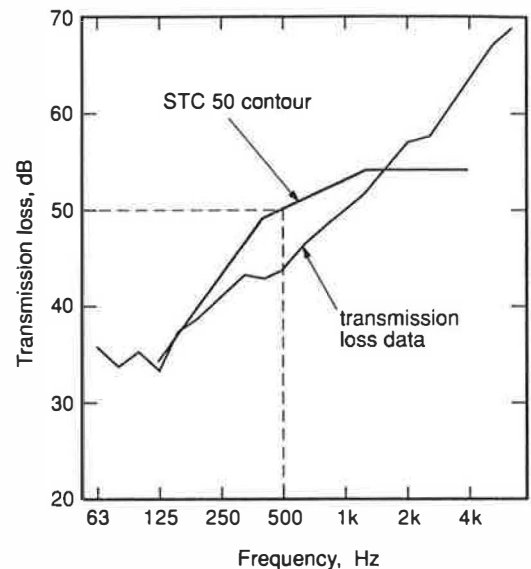

Figure 2 STC contour fitted to TL curve for concrete block

The 1990 National Building Code of Canada (NBC)⁴ requires an STC rating of 50 for party walls and floors. This is an increase of 5 dB over previous Code requirements. Acousticians, however, usually recommend a design STC of more than 50, say 55 or 60. There are several reasons for this:

- Constructions often perform less well in buildings than they do in laboratory tests. A higher component design rating gives a better chance of meeting Code and overall system requirements; it provides a margin of safety.
- The higher the STC, the less chance there is that building occupants will complain. The higher quality does not necessarily increase costs.
- As shown in Figure 2, the STC fitting procedure only extends to 125 Hz. Thus, walls may be quite weak below 125 Hz, yet this excessive transmission at low frequencies may not influence the STC rating.

Designers will not be aware of these weaknesses if they only look at STC ratings. Low frequency noise can be a great problem.

Specifying higher STC ratings provides some protection against poor low frequency sound insulation. In fitting the STC contour to the TL curve, the 8 dB rule states that no TL value can be more than 8 dB below the STC curve. Thus the STC is unlikely to be high when the low-frequency transmission loss is very poor. An example of the protection this rule provides is shown later in Figure 7.

Increasing the STC of Block Walls

One of the most effective ways of increasing sound transmission loss is to use double layer construction, that is, two layers of

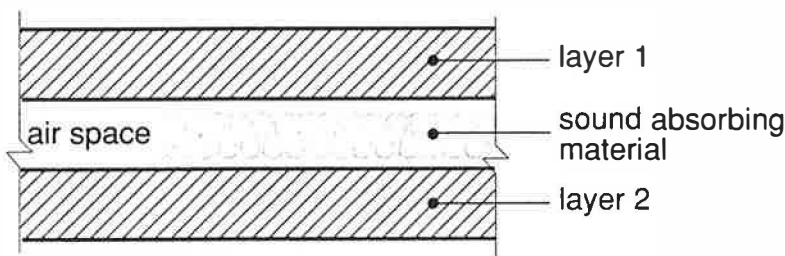

Figure 3 Idealized wall section

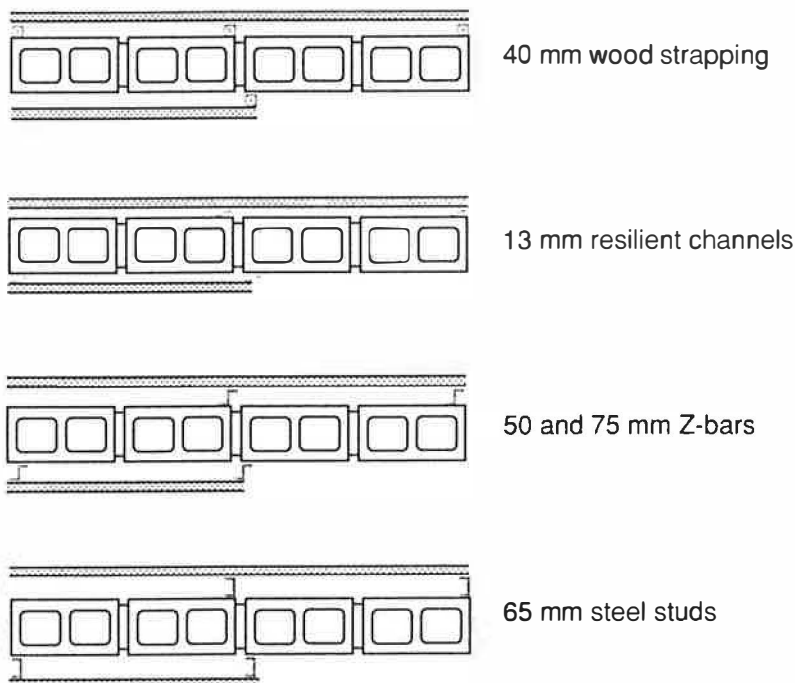

Figure 4 Wall assemblies tested for sound transmission loss

material separated by an air space (Figure 3). Increasing the weight of the layers in a double wall, increasing the depth of air space, or adding sound-absorbing material, all increase the transmission loss and therefore the STC rating for a double wall. There should be no solid connections between the two layers. Resilient connections, such as those provided by resilient metal channels or non-load-bearing steel studs, are acceptable in most cases.

Concrete block is a popular building material that offers fairly good sound insulation because of its weight. Normal weight block (19 cm) provides about STC 50, or less, depending on the weight of the block. This is not quite good enough to be sure of meeting the 1990 NBC requirements; in any case, in a home or office the block has to be finished, usually with drywall. To improve the sound transmission loss through block walls, one can support the drywall away from the block to form a double or triple layer wall. It is important to know just what effects one can expect with different methods of attaching drywall. What STC ratings can be achieved? What happens at low frequencies?

At IRC we looked at different ways of attaching drywall to block walls to answer these questions⁵ (Figure 4). With the exception of the wood strapping, all of the supports were resilient. Walls were tested with and without glass fibre batts in the cavities and with one or both sides finished.

Figure 5 presents the results for bare block, for the block with 16 mm drywall supported on 13 mm resilient channels, and for 16 mm drywall supported on 75 mm z-bars. The curves for the walls with added drywall fall below the curve for the bare wall at the left, or low-frequency, end of the graph. This is caused by a resonance between the drywall and the air in the cavity. The air acts as a spring and the drywall bounces on it, much like a ball bouncing on a piece of elastic. The larger the air cavity or the heavier the drywall, the lower the frequency where the resonance occurs. This resonance is called the mass-air-mass resonance. The first mass is the drywall, the second is the block, which is so heavy that it has little influence on the position of the resonance.

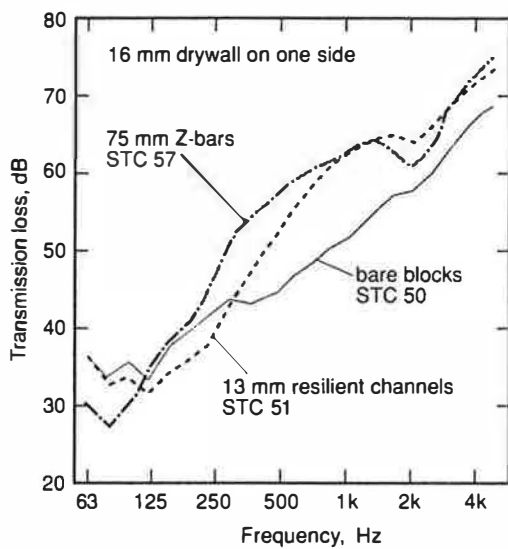

Figure 5 Sound transmission loss through different wall assemblies

Figure 6 compares the results for a 50-mm deep cavity with and without glass fibre in it. The sound absorbing material makes the cavity respond as if it were about 40% larger and the resonance moves to a lower frequency. In general, when sound absorbing material is added to a cavity, the transmission loss improves and, if the resonance frequency is low enough, the STC usually increases.

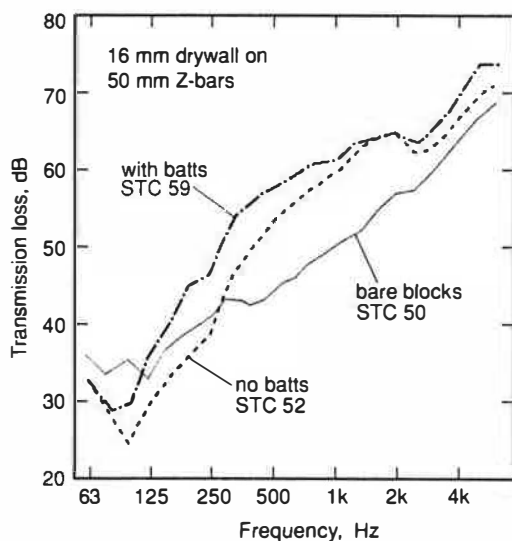

Figure 6 Sound transmission loss through walls with and without insulation in the cavity

Table 1 summarizes the results where drywall is attached on one or both sides of the wall. As the air space increases, the STC goes up. Treating both sides also usually increases the STC. The highest value obtained was STC 72. There are, however, one or two peculiar results. Adding drywall, resilient metal channels and glass fibre on both sides of the wall caused the STC to drop one point!

Drywall attachment	No glass fibre		With glass fibre	
	One side	Both sides	One side	Both sides
Bare blocks applied directly	50			
13 mm resilient channels	51	49	54	49
40 mm wood furring	53	54	55	59
50 mm Z-bars	52	52	59	64
65 mm steel studs	58	57	60	72
75 mm Z-bars	57		61	

Table 1 STC ratings for 190 mm normal weight block walls, with different methods of mounting 16 mm drywall, with and without glass fibre batts filling the cavities

When the first layer of drywall is added (Figure 7), the transmission loss increases above a certain cross-over frequency, about 200 Hz, and decreases below that frequency relative to the bare blocks. The mass-air-mass resonance occurs at around 100 Hz in this case. Adding the same drywall system on the second side (Figure 7) improves the transmission loss further above the cross-over frequency, but below that frequency, the transmission loss gets still worse. In this case, because the air gap is too small, the effect of the mass-air-mass resonance is to pull down the TL curves at frequencies within the range of the STC calculations and the STC is reduced in one case. The vertical line shows the lower limit of the STC calculation.

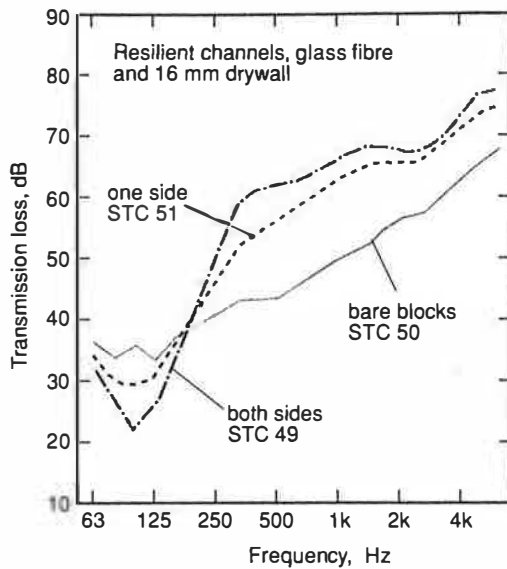

Figure 7 Poor transmission loss at low frequencies limits overall STC improvement suggested by better performance at higher frequencies

Despite the fact that applying treatment on both sides increases the TL at mid- and high frequencies, the STC is limited by the 8 dB rule at 125 Hz. (As mentioned above, the 8 dB rule states that no TL value can be more than 8 dB below the STC curve.) Thus the STC provides some protection, but only some, against poor TL at lower frequencies.

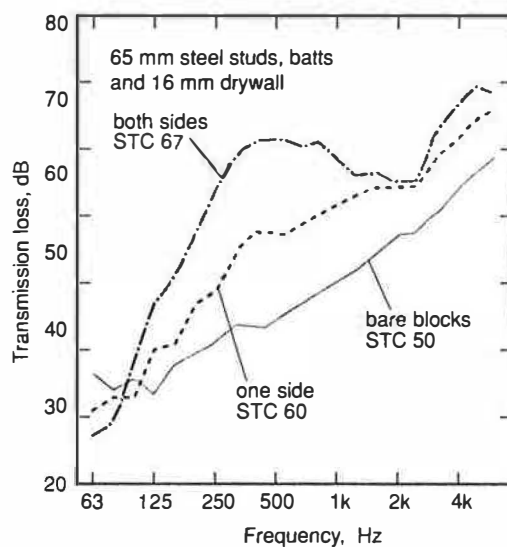

Figure 8 Poor transmission loss performance (low mass-air-mass resonance) below 125 Hz does not affect the STC rating

If the mass-air-mass resonance is low enough, these detrimental effects occur below 125 Hz (Figure 8) and the STC is not reduced. However, there are still reductions in the low frequency transmission loss. Changes in low frequency sound insulation may make a system unsuitable for a use where low frequency noise is expected to be a problem. Where low frequency transmission loss is important, sound transmission loss curves should be examined to be sure that any proposed wall system is good enough. These examples show why it is important to remember that STC is an average and that only data from 125 Hz upward are used in its calculation.

Summary of Findings and Recommendations

As a result of the understanding gained through the measurement series, Table 2 gives recommended cavity depths to be used behind drywall attached to concrete blocks.

	Number of layers of 13 mm drywall		Number of layers of 16 mm drywall	
	1	2	1	2
No sound absorbing material	90	45	75	40
With sound absorbing material	65	30	55	30

Table 2 Recommended minimum cavity depths, mm, behind drywall layers added to concrete block

The cavity thicknesses are somewhat larger than those normally used; the recommendations ensure that the added materials do not decrease the STC of the wall system relative to the bare blocks. There are some indications that smaller cavity thicknesses may be acceptable with lightweight, more porous blocks. Research is in progress to clarify this.

Essential points from this study are:

- mass-air-mass resonance has a great deal of effect on STC, and much more on low frequency sound transmission loss;

- the greater the airspace, the lower the mass-air-mass resonance and the greater the STC;
- the addition of sound absorbing material lowers mass-air-mass resonance;
- the use of resilient connections instead of rigid supports increases high frequency performance but the STC rating may be still controlled by low frequency behaviour;
- if adding a layer on one side causes a detrimental resonance, then adding a similar layer on the second side makes the resonance worse.

Figure 9 illustrates the differences that can be achieved by doing things correctly. For bare blocks, the STC is about 50. For the price of some sound absorbing material and a few centimetres of space, an STC of 72 can be obtained.

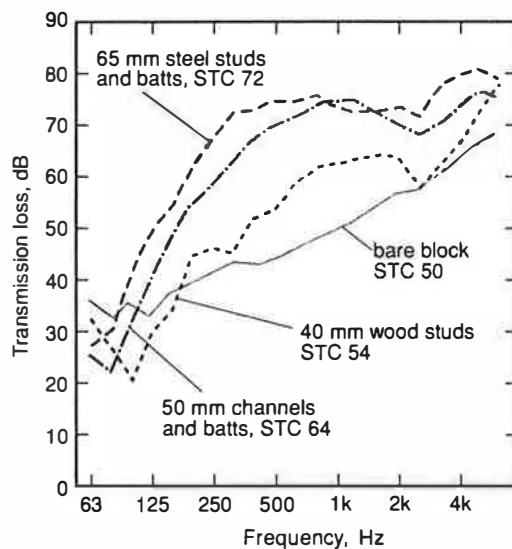

Figure 9 Significant improvements in transmission loss achieved with simple constructions

Plumbing Noise

Many articles give general advice on how to deal with plumbing noise. The most frequent recommendation is to mount the pipes and all devices resiliently (Figure 10). Many questions about the effectiveness of these techniques in Canadian construction have, until now, remained unanswered. Recently IRC completed a study of some resilient mounting techniques and other

methods that might be used to control plumbing noise in buildings.

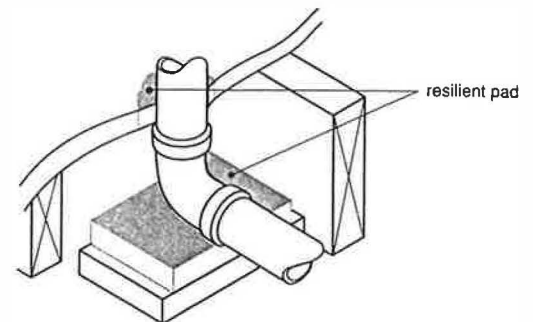

Figure 10 Possible means of isolating plumbing from sound-conducting elements

The device used to generate the noise in the plumbing was a standard source that is used in European tests of plumbing noise (Figure 11). Water is forced to pass through two obstructions in the pipe, the first with four small holes, the second with one. This creates a lot of turbulence and noise; about 5 dB more noise than a conventional North American faucet.

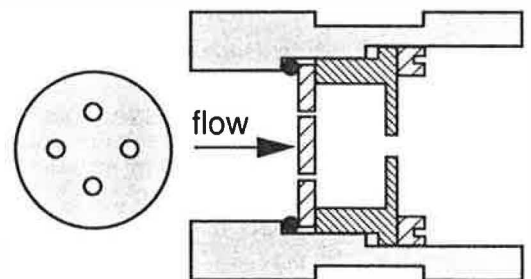

Figure 11 Cross section through the standard noise source

Resilient Wrappings

Adding resilient wrapping (Figure 12) between the pipe and the clamping hardware is one method of achieving a resilient mount and means that vibrations in the wall of the pipe are not so easily transmitted to the wood studs and thence to the drywall. The objective is to interrupt the path the sound must follow on its way to being radiated.

Table 3 shows the advantages of using different resilient wrappings around a

copper pipe. A soft material can reduce noise by about 20 dBA relative to the rigid clamps. Generally the softer the material, the greater the noise reduction. Notice that the noise level is reduced; it is not eliminated. Adding wedges simulates errors. The wedges increased the noise levels by about 8 to 10 dBA.

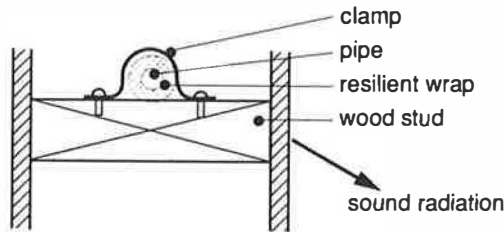

Figure 12 Plumbing noise test set-up

Resilient material	Measured Noise Levels, dBA		
	Pipe diameter		
	13 mm	19 mm	25 mm
rigid clamps	73	71	72
2 mm cork + clamp	68	64	63
13 mm felt + clamp	64	59	56
solid neoprene + clamp	59	58	57
neoprene foam + clamp	54	54	50
no clamps	47		
neoprene foam + 1 wedge	62		
neoprene foam + 2 wedges	65		
neoprene foam + 3 wedges	65		

Table 3 A-weighted noise levels measured with various attachments of pipes to studs

Wall System Modifications

As an alternative to resilient mounting of pipes, or where noise reduction is required in an existing installation, one might consider changes to the wall system. Several means of improving the basic wall were investigated. In all cases the pipes were directly attached to the wood studs; no resilient materials were used.

The results (Table 4) show that even though the pipes are directly clamped to the wood studs, substantial noise reductions can be achieved through the use of sound absorbing material and resilient metal channels. The lowest noise level given in Table 4 is about the same as that given in Table 3,

(except for the measurement in Table 3 where the absence of clamps provided for no contact at all with the studs). It is tempting in problem situations to blow sound absorbing material, either glass or cellulose fibre, into the wall. This table shows that both materials give about the same noise levels and that better results are obtained by introducing resilient metal channels to support the drywall.

Wall finish	Measured Noise Levels, dBA	
	Pipe diameter	
	13 mm	25 mm
1 layer drywall	73	71
1 layer drywall with batts in cavity	73	68
2 layers drywall	70	66
1 layer drywall with cellulose fibre in cavity	—	67
2 layers drywall with batts in cavity	68	66
1 layer drywall on resilient channels with batts in cavity	64	62
2 layers drywall on resilient channels with batts in cavity	56	56

Table 4 Noise levels measured from modified wall systems

Combined Approach

Using resiliently mounted pipes and improving the wall system gives even greater plumbing noise reduction. Table 5 gives results for several types of wall where the pipes were supported using 13 mm thick neoprene foam resilient wrapping. The best construction in this case is about 30 dBA quieter than the wall with a single layer of drywall and the pipes solidly mounted.

Wall finish	Measured Noise Levels, dBA	
	Pipe diameter	
	13 mm	25 mm
1 layer drywall	54	55
1 layer drywall with batts in cavity	51	50
2 layers drywall	51	51
2 layers drywall with batts in cavity	48	47
1 layer drywall on resilient channels with batts in cavity	44	44
2 layers drywall on resilient channels with batts in cavity	42	4

Table 5 Noise levels with wall modifications and 13 mm thick neoprene foam resilient mounting

Comparison of Pipe Materials

Different pipe materials may be expected to transmit sound energy differently. Measurements were made with two commonly available materials used for supply pipes, copper and plastic. The plastic pipe was Schedule 80 pipe with a wall thickness of 4 to 5 mm depending on diameter. Comparisons are given in Table 6 for the average of 13, 19 and 25 mm diameters of these two types of pipe, with and without a resilient wrapping. The plastic pipes are significantly quieter than the copper pipes when no resilient wrapping is used but when the soft foam wrap is used, there is little difference. However, if there is unintended contact, the noise generated will be less with the plastic pipe.

Material	Measured Noise Levels, dBA	
	solid clamps	neoprene foam + clamps
Copper	72	54
Plastic	62	52

Table 6 Comparison of sound transmitted by copper and plastic pipe

Conclusions

The general conclusions to be drawn from this study are that the use of resilient supports for plumbing pipes and other systems is very important. Noise reductions up to about 15 dBA can be obtained relative to systems where no resilient mounts are used for pipes.

Adding extra drywall always reduces the noise; adding resilient metal channels is more effective and provides some margin if construction errors result in accidental solid contact between pipes and structure.

Flanking Noise

In the laboratory we take great care to mount specimens so that the only path for sound is through the specimen; there is no solid connection between the specimen and the rooms on either side (Figure 13). This can be done in the laboratory, but not so easily in a building. Figure 14 shows the

many paths that sound can follow when it travels between two rooms. Ideally, one would resiliently mount all surfaces in a room to attenuate all direct and flanking paths.

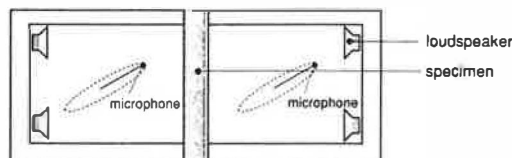

Figure 13 Laboratory set-up for measurement of sound transmission loss

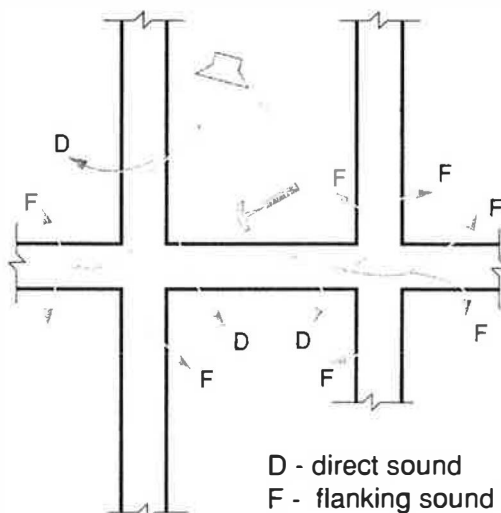

Figure 14 Flanking sound through building construction

A sawcut in the floor eliminates a horizontal flanking path along the plywood (Figure 15). Such sawcuts are recommended. But there is also the vertical path to be considered. Sound, especially impact noise, can travel down the walls to the space below (Figure 16). To reduce transmission along this path, one can use resilient metal channels (Figure 17). The channels have the advantage that they also help to reduce plumbing noise. This approaches the ideal situation in building noise control, where all surfaces in a room to be protected are mounted resiliently.

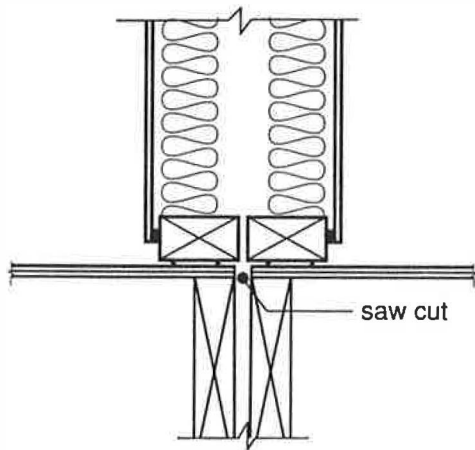

Figure 15 Saw cut to break sound flanking through floor

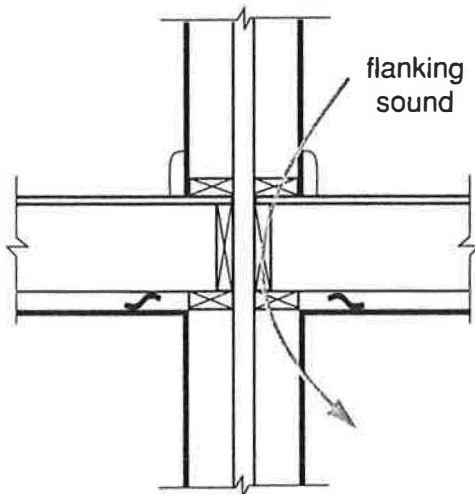

Figure 16 Sound flanking vertically through walls

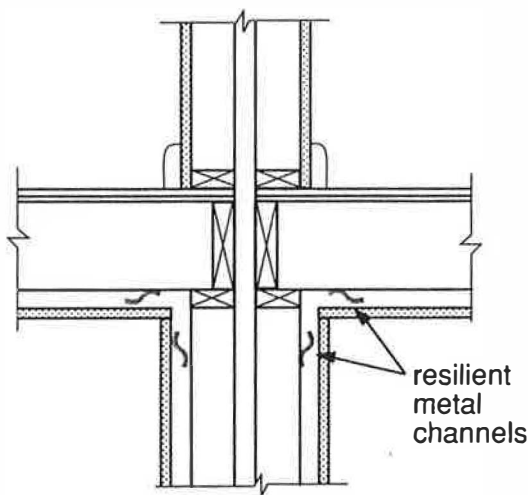

Figure 17 Resilient channels used to reduce flanking noise

Noise Leaks

Two types of noise leaks are common causes of sound problems in small buildings; leakage through electrical outlets is relatively minor, while leakage around interior partitions can be major.

Electrical and Other Wiring Outlets

Leaks around electrical and other wiring outlets are a common problem, especially when the outlets are back-to-back (Figure 18). One recommended solution is to offset the boxes (Figure 19). This is especially effective when the wall is filled with sound absorbing material. Leaks usually permit only high-frequency sound to pass through. Forcing high-frequency sound to travel a long path through sound absorbing material is a good way to attenuate it, since sound absorbing material is most effective at high frequencies. The blocking panels shown in Figure 20 are another way of achieving good sound insulation while still having back-to-back outlets.

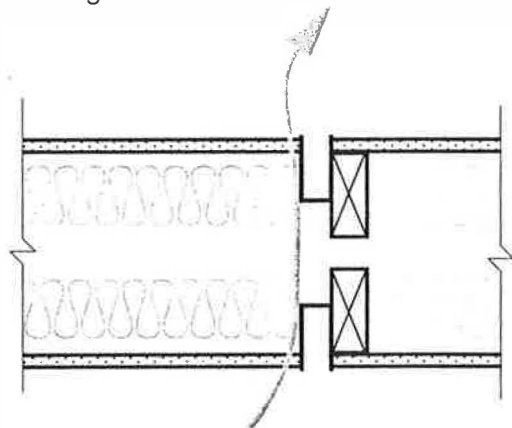

Figure 18 Leakage through electrical boxes

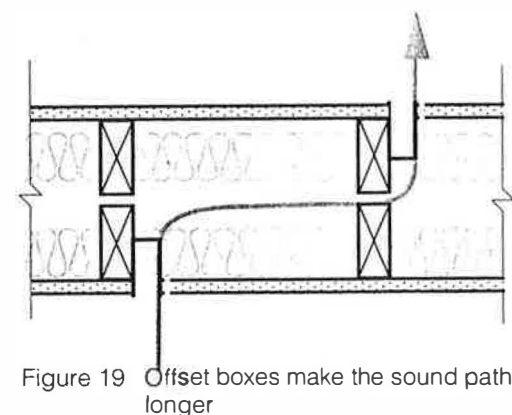
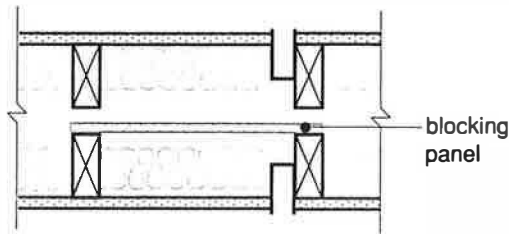
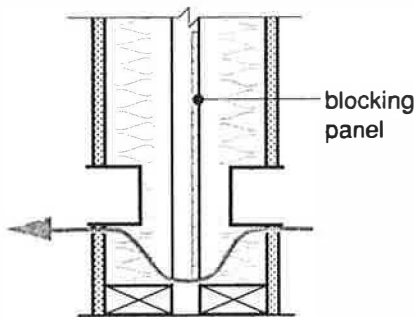

Figure 19 Offset boxes make the sound path longer



a) Plan



b) Section

Figure 20 Blocking panels force the sound to travel through sound absorbing material

Partitions and Ceiling Spaces

This major leak is common in office buildings with suspended ceilings. Sound is transmitted via the space above the ceiling where the common wall does not extend to the slab above (Figure 21). There are two approaches to dealing with this problem: either the partition is made full height or the attenuation of the path through the plenum

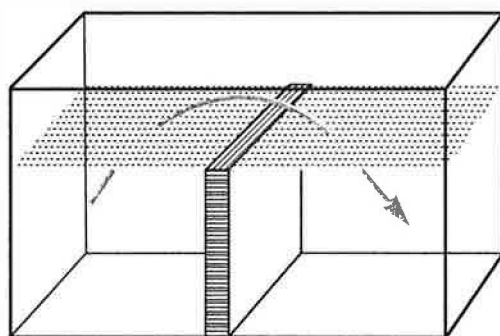

Figure 21 Noise leak through plenum space

and ceiling is increased. For each of these approaches there are variants.

Ceiling treatment

Three approaches for increasing the plenum/ceiling attenuation were tested⁶ (Figure 22). In the first case, a layer of 6 mm drywall was laid on top of tiles. The test results are presented in terms of increased noise isolation class (NIC). NIC is a measure of sound insulation that is very similar to sound transmission class (STC). However, it includes the effects of the room, whereas these are removed by calculation before the STC is worked out. Adding 6 mm drywall increased the sound insulation by 5 dB, to NIC 37.



NIC 37

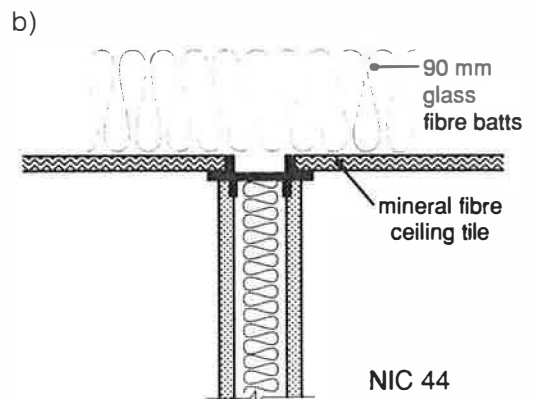

NIC 44

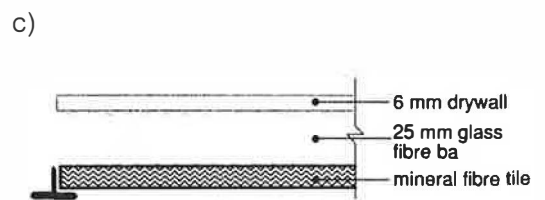

NIC 41

Figure 22 Plenum/ceiling treatments
 a) 6 mm drywall on mineral fibre tile
 b) 90 mm glass fibre batts on ceiling tiles
 c) 25 mm glass fibre batts between the drywall and the tiles

Adding 90 mm glass fibre batts on top of mineral fibre tiles is intended to absorb the sound as it propagates in the plenum. The NIC increased as the width of the batts above the wall was increased. The ceiling had typical openings for air handling. Once the width of the batts had reached about 3.5 m, there was a marked reduction in improvement when the width was further increased (Figure 23). This result is probably specific to the particular test arrangement.

These two approaches may be combined. In the test case the glass fibre was not as thick as in the previous scenario but this is compensated for by the addition of drywall. In the test case an NIC of 41 was achieved. Sound that penetrates air-handling openings could reach the plenum and propagate there without interacting with the glass fibre. It would be better to add another layer on top of the drywall, but this increases the complexity of the arrangement.

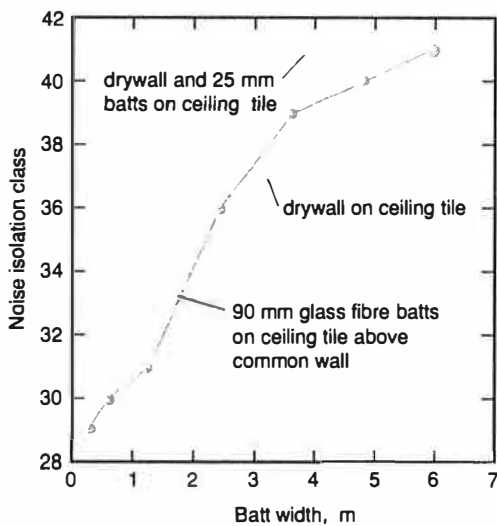

Figure 23 Noise isolation class achieved by plenum/ceiling treatment

Partition extension

The gap between the top of the wall and the floor slab above may be blocked in several ways. Simply extending the wall should give sound insulation values appropriate for the wall (Figure 24). The ceiling boards already provide some attenuation, so the blocking panels need not provide as much attenuation as the wall itself (Figure 25).

Adding panels to extend the wall can be very difficult because of wires, pipes and other services in the plenum space. Another technique that works well is to fill the space

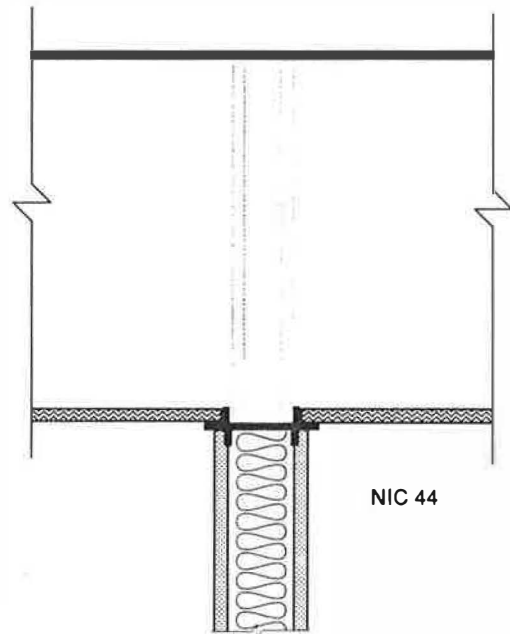

Figure 24 Wall construction extended through plenum space

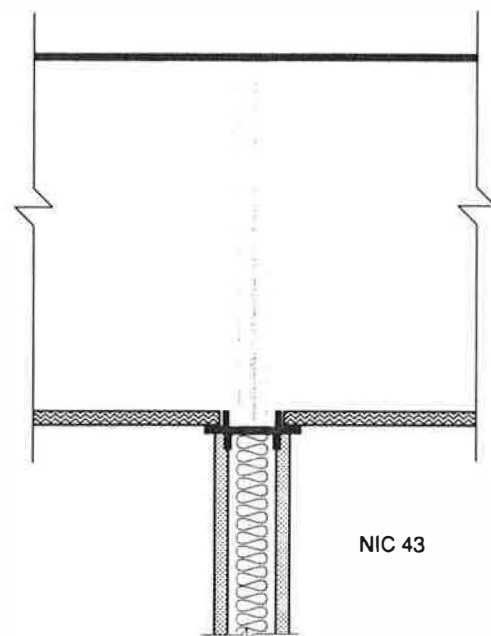

Figure 25 Blocking panels carried through plenum space

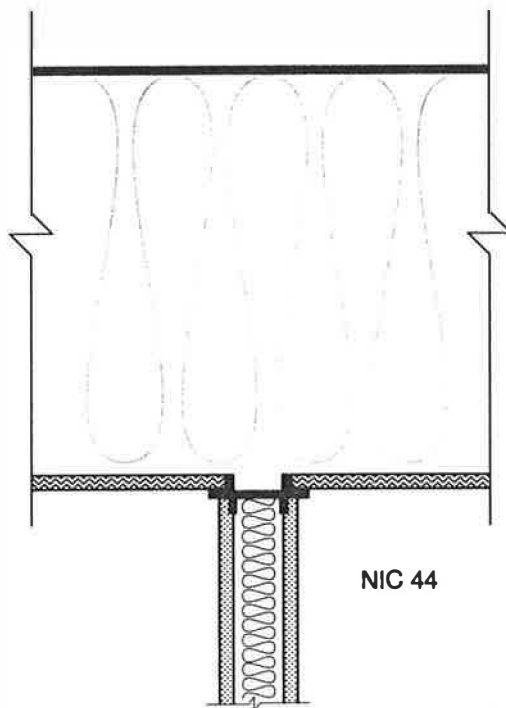

Figure 26 Plenum packed with glass fibre above the partition wall – the fuzz-wall approach

above the wall with batts of glass fibre or mineral wool (Figure 26). This is easy to pack in around pipes and other obstructions. This treatment, known as the fuzz-wall approach, can make the path through the ceiling space negligible.

There is little point in attenuating sound in the plenum if there are other major sound leaks below the ceiling, for example, where the ceiling tiles meet the top of the wall or where the wall meets side walls or the floor.

Extending the wall to close the plenum interferes with airflow and ventilation when the space above the ceiling is used as a return air plenum. Additional ductwork penetrating the barrier will be necessary to restore the airflow. Since this ductwork introduces a path for sound, it should be lined with sound absorbing material.

Sound leaks are one of the most common causes of poor sound insulation. Repairing leaks or preventing their occurrence is not difficult in most cases. Often caulking is all

that is necessary. The cases examined here are a little more complicated but they too can be controlled using sound barrier materials and sound absorbing materials.

Summary

Noise control in buildings usually involves no more than the correct application of solid barrier materials, resilient materials and sound absorbing materials. The basic principles are fairly simple and complications such as the mass-air-mass resonance mentioned above are relatively infrequent.

References

- 1 *Proceedings of Building Science Insight '85: Noise Control in Buildings*, Institute for Research in Construction, National Research Council Canada, Ottawa, NRCC 27844, 1987.
- 2 "Noise Control." Builders' Series, Canada Mortgage and Housing Corporation, NHA 6012, Ottawa, 1988.
- 3 "Classification for Rating Sound Insulation." American Society for Testing and Materials, E413 - 87, 1987.
- 4 "National Building Code of Canada 1990." Associate Committee on the National Building Code, National Research Council Canada, Ottawa, NRCC 30619, 1990.
- 5 Warnock, A.C.C., "Sound Transmission Loss Measurements through 190 mm and 140 mm Blocks with Added Drywall and through Cavity Block Walls." Internal Report No. 586, Institute for Research in Construction, National Research Council Canada, Ottawa, 1990.
- 6 Kruger, K., "The Effect of Various Parameters on the Sound Insulation between Offices." Proceedings of Acoustics Week in Canada, Alberta Public Works, Edmonton, 1987.