

AIVC  
#13019



R

# RESEARCH REPORT

A GUIDE TO MECHANICAL EQUIPMENT  
FOR HEALTHY INDOOR ENVIRONMENTS

HEALTHY  
HOUSING AND  
COMMUNITIES  
SERIES



HOME TO CANADIANS  
Canada

## CMHC—Home to Canadians

Canada Mortgage and Housing Corporation (CMHC) is home to Canadians. In everything we do, we help Canadians live in safe, secure homes. As the Government of Canada's national housing agency, we play a major role in Canada's housing industry. CMHC develops new ways to finance home purchases. We encourage innovation in housing design and technology. Our mortgage loan insurance helps Canadians realize their dream of owning a home.

Canadians benefit from our work with public, private and not-for-profit partners to improve the quality, accessibility and affordability of housing everywhere in Canada.

CMHC assistance helps low-income and older Canadians, people with disabilities and Aboriginals live in decent, affordable homes. We create jobs for Canadians with products and services that help the housing industry export its knowledge and skills to other countries.

CMHC's leading-edge research improves the quality and affordability of housing. To help Canadians benefit from our housing expertise and make informed decisions, CMHC has become Canada's largest publisher of housing information. We also have Canada's most comprehensive selection of information about homes and housing.

Canadians can easily access our information through retail outlets and CMHC's regional offices.

You can also reach us by phone at

1 800 668-2642 (outside Canada, (613) 748-2003)

by fax at (613) 748-4069

To reach us online, visit our home page at [www.cmhc-schl.gc.ca](http://www.cmhc-schl.gc.ca)

Canada Mortgage and Housing Corporation supports the Government of Canada policy on access to information for people with disabilities. If you wish to obtain this publication in alternative formats, call 1 800 668-2642.

# **A GUIDE TO MECHANICAL EQUIPMENT FOR HEALTHY INDOOR ENVIRONMENTS**

*by*

***David Rousseau, Archemy Consulting Ltd.***

***Dara Bowser, Bowser Technical Inc.***

***Chris Mattock, Habitat Design + Consulting Ltd.***

*for*

***Virginia Salares, project manager***

***Canada Mortgage and Housing Corporation***

CMHC offers a wide range of housing-related information, For details, call 1 800 668-2642 or visit our Web site at [www.cmhc-schl.gc.ca](http://www.cmhc-schl.gc.ca)

Cette publication est aussi disponible en français sous le titre : Guide d'équipement mécanique pour un environnement intérieur sain, PF0372.

This research project was (partially) funded by Canada Mortgage and Housing Corporation ("CMHC"). The contents, views and editorial quality of this report are the responsibility of the author(s) and CMHC accepts no responsibility for them or any consequences arising from the reader's use of the information, materials and techniques described herein.

Canadian Cataloguing in Publication Data

Rousseau, David

Main entry under title:

A guide to mechanical equipment for healthy indoor environments

Issued also in French under title: Guide d'équipement mécanique pour un environnement intérieur sain

Includes bibliographical references

ISBN 0-660-17989-X

Cat. no. NH15-343/2000E

1. Dwellings – Heating and ventilation – Health aspects – Handbooks, manuals, etc.
  2. Heating – Equipment and supplies – Handbooks, manuals, etc.
  3. Ventilation – Equipment and supplies – Handbooks, manuals, etc.
  4. Water – Purification – Equipment and supplies – Handbooks, manuals, etc.
  5. Housing and health – Canada
- I. Mattock, Chris
  - II. Bowser, Dara
  - III. Canada Mortgage and Housing Corporation
  - IV. Title

TD883.17.R68 2000      613'.5      C00-980015-8

© 2000 Canada Mortgage and Housing Corporation. All rights reserved. No portion of this book may be reproduced, stored in a retrieval system or transmitted in any form or by any means, mechanical, electronic, photocopying, recording or otherwise without the prior written permission of Canada Mortgage and Housing Corporation. Without limiting the generality of the foregoing no portion of this book may be translated from English into any other language without the prior written permission of Canada Mortgage and Housing Corporation.

Printed in Canada  
Produced by CMHC

# PURPOSE

---

A house consists of two major components—the house envelope and the mechanical equipment. The performance of the house over time depends, to a large extent, on the soundness and quality of the house envelope and the mechanical equipment. The occupants also have a major contribution to the house performance. The occupancy factors include density (high or low), the habits, hobbies and lifestyles of the occupants, the kinds and amount of furnishings and belongings they bring and store in the house, and how they maintain and operate both the house and equipment.

A book on building materials, *Building Materials for the Environmentally Hypersensitive*, was prepared to assist homeowners, architects and builders in selecting building materials for residential construction. *A Guide to Mechanical Equipment for Healthy Indoor Environments* was written for the same purpose, but the focus is on mechanical equipment. It discusses residential heating and cooling systems, ventilation, filtration and water purification.

Homeowners or contractors who are building a new house can use the guide for selecting new equipment. Similarly, those who are planning retrofits can compare different equipment to replace older, less efficient systems. The guide also discusses balanced heat recovery ventilation systems, which every homeowner should know about.

Throughout the guide, references have been made to the needs of environmentally hypersensitive individuals. While the average person typically applies capital and operating cost considerations in selecting equipment, hypersensitive individuals rank the potential impact of the equipment on air quality or health high on their criteria list. *Information pertinent to hypersensitive individuals is presented in italics*, to make it easily recognized from the general discussion.

Virginia Salares  
Senior Researcher  
Research Division

Tel. (613) 748-2032  
Fax (613) 748-2402

# ***ACKNOWLEDGEMENTS***

---

We are indebted to the Heating, Refrigerating and Air Conditioning Institute for reviewing the manuscript. Peter Russell's invaluable suggestions are also acknowledged.

# **EXECUTIVE SUMMARY**

---

This publication summarizes current information on heating (both space and hot water heating), cooling and ventilation systems and equipment used in low-rise, residential buildings with regards to their effect on indoor air quality. An additional discussion of water purification systems is also presented. The publication is intended to be an information source primarily for environmentally hypersensitive individuals and, second, for the general public and the homebuilding industry as a reference on mechanical systems.

The document provides background information for the reader by presenting definitions of specialized terminology used in the publication and with a discussion of a house as a system. This latter discussion shows how the operation of mechanical equipment and the indoor air quality in a home are affected by other elements such as insulation, air barriers and the types of interior finishes used.

Various types of heating, cooling, ventilation and air filtration systems are presented with a discussion of how they affect the indoor air quality of a home. Retrofitting existing heating systems to improve indoor air quality is also addressed. A discussion focussed on the specific needs of the environmentally hypersensitive is presented at the end of each section.

The report concludes with a section on water quality and the types of water treatment systems available for residential applications. The appendices contain lists of suppliers of heating, cooling, ventilation and water treatment equipment indexed both by type of equipment and by supplier.

<b>4. VENTILATION AND FILTRATION BASICS</b> .....	<b>.52</b>
Exhausting Pollutants at Source .....	.52
Natural vs. Mechanical Ventilation .....	.52
Ventilation Effectiveness and Distribution .....	.52
Ventilation System Operation .....	.53
Types of Mechanical Ventilation .....	.56
Central Exhaust Ventilator .....	.64
Demand-Controlled CEV System .....	.65
Recirculating Central Ventilation Systems (RCVs) .....	.67
Balanced Ventilation Systems (Heat Recovery Ventilators) .....	.69
Air-Inlet Devices .....	.75
Central Exhaust Ventilator .....	.76
Duct Fans .....	.76
Ducts, Flexible Duct and Sealers, Duct Insulation .....	.77
Exhaust Fans .....	.78
Heat Recovery Ventilators .....	.79
Kitchen Range Exhaust (Outside Vented) .....	.85
Recirculating Central Ventilator .....	.86
Supplementary Ventilation Air Filtration for HRVs .....	.87
Registers, Grilles and Diffusers .....	.87
<b>5. HEATING AND VENTILATING SYSTEM RETROFITS</b> .....	<b>.88</b>
Adapting the Warm-Air Furnace .....	.96
<b>6. FILTRATION AND AIR CLEANING SYSTEMS</b> .....	<b>.96</b>
The Purpose of Filtration .....	.96
Particulate Filters .....	.96
Installation and Use .....	.101
Other Special Considerations for the Environmentally Hypersensitive .....	.103
Air Ionizers/Ozone Generators .....	.106
Adsorption Air Filters .....	.106
Built-In Vacuum .....	.107
Electronic Air Filters .....	.108



Extended Media Filters .....	108
Furnace Filter Upgrades .....	109
Passive Electrostatic Air Filter .....	110
Portable Air Cleaners .....	111
Reactive Gas Scrubbers .....	112
Turbulent Flow Precipitators .....	113
<b>7. WATER TREATMENT .....</b>	<b>114</b>
Water Purification Systems and Equipment .....	114
Equipment Cost .....	116
Equipment Maintenance .....	117
Water Conservation .....	117
Charcoal/Carbon Filter .....	117
Distillation Equipment .....	118
Membrane Filters .....	119
Metal or Mineral Removal Filters .....	120
Point-of-Use Filters .....	120
Sediment Filters .....	121
Sterilization Units .....	122
Whole-House Water Filtration .....	122
<b>SELECTED REFERENCES .....</b>	<b>124</b>
<b>APPENDICES</b>	
A: Definitions .....	A-1
B: How to Select a Mechanical Contractor .....	B-1
C: Manufacturer and Supplier Listings .....	C-1

# ***LIST OF TABLES***

---

**Table 1:** Boiler Summary Table .....38

**Table 2:** Water Heater Summary Table .....43

**Table 3:** Furnace Summary Table .....45

**Table 4:** Duct Sizing .....59

**Table 5:** HRV Summary Table .....84

**Table 6:** Filter Performance .....102

# LIST OF FIGURES

---

<b>Figure 1:</b> House as a System as Applied to Heating Climates—Step 1: Super Insulation, No Air Barrier . . . . .	3
<b>Figure 2:</b> House as a System as Applied to Heating Climates—Step 2: Incorporation of a Continuous Air Barrier . . . . .	4
<b>Figure 3:</b> House as a System as Applied to Heating Climates—Step 3: Ventilation and Pollution Source Control . . . . .	5
<b>Figure 4:</b> House as a System as Applied to Heating Climates—Step 4: Balanced Heat Recovery Ventilation . . . . .	6
<b>Figure 5:</b> Forced Air Heating System with a Naturally Aspirated Furnace . . . . .	10
<b>Figure 6:</b> Typical Gas Induced Draft Furnace . . . . .	11
<b>Figure 7:</b> Sealed Combustion Condensing Gas High-Efficiency Furnace . . . . .	12
<b>Figure 8:</b> Fan Coil System . . . . .	14
<b>Figure 9:</b> Outdoor Air Intake Ventilation System . . . . .	17
<b>Figure 10:</b> Heat Recovery Ventilator Combined with Forced Air Heating . . . . .	18
<b>Figure 11:</b> Air Source Heat Pump . . . . .	22
<b>Figure 12:</b> Ground Source Heat Pump . . . . .	23
<b>Figure 13:</b> Baseboard Convection Heater . . . . .	26
<b>Figure 14:</b> Liquid Filled Electric Heaters . . . . .	26
<b>Figure 15:</b> Radiant Heating . . . . .	28
<b>Figure 16:</b> Direct Gain Passive Solar Heating . . . . .	31
<b>Figure 17:</b> Compact Air Conditioners . . . . .	34
<b>Figure 18:</b> Typical Electric Boiler . . . . .	35
<b>Figure 19:</b> Naturally Aspirated Gas Boiler . . . . .	36
<b>Figure 20:</b> Induced Draft Gas Boiler . . . . .	36
<b>Figure 21:</b> Condensing Gas Boiler . . . . .	37
<b>Figure 22:</b> Electric Hot Water Tank . . . . .	39
<b>Figure 23:</b> Naturally Aspirated Gas Hot Water Tank . . . . .	40
<b>Figure 24:</b> Induced Draft Water Heater . . . . .	41

<b>Figure 25:</b> Sealed Combustion Gas Water Heater . . . . .	42
<b>Figure 26:</b> Comparison of Natural and Distributed Mechanical Ventilation . . . . .	53
<b>Figure 27:</b> Ventilation Effectiveness . . . . .	54
<b>Figure 28:</b> Ventilation—Supply Only . . . . .	57
<b>Figure 29:</b> Ventilation—Exhaust Only . . . . .	58
<b>Figure 30:</b> Passive Wall Inlet . . . . .	59
<b>Figure 31:</b> Dehumidistat . . . . .	60
<b>Figure 32:</b> Range Hood Ventilation System . . . . .	62
<b>Figure 33:</b> Central Exhaust Ventilation System . . . . .	65
<b>Figure 34:</b> Humidity-Actuated Exhaust Grille . . . . .	66
<b>Figure 35:</b> Humidity-Actuated Through Wall Supply . . . . .	66
<b>Figure 36:</b> Recirculating Central Ventilation System . . . . .	68
<b>Figure 37:</b> Balanced Ventilation System . . . . .	70
<b>Figure 38:</b> Heat Recovery Ventilator . . . . .	71
<b>Figure 39:</b> Central Heat Recovery Ventilator for Use with Baseboard or Radiant Heating . . . . .	72
<b>Figure 40:</b> Plate Type HRV Cores . . . . .	79
<b>Figure 41:</b> Rotary Wheel HRV Core . . . . .	80
<b>Figure 42:</b> Heat Pipe HRV Core . . . . .	80
<b>Figure 43:</b> Cross-Leakage and Defrost Methods in HRVs . . . . .	82
<b>Figure 44:</b> Other HRV Defrost Methods . . . . .	83
<b>Figure 45:</b> Built-Up Air Handler to Replace Furnace . . . . .	90
<b>Figure 46:</b> Outside Air Connection . . . . .	92
<b>Figure 47:</b> HRV Connection to Forced Air Heating System . . . . .	93
<b>Figure 48:</b> New Filter Location with Length of Straight Duct Before the Filter . . . . .	94
<b>Figure 49:</b> Filter Location with New Bottom Elbow . . . . .	95
<b>Figure 50:</b> Pleated Medium-Efficiency Filter . . . . .	97
<b>Figure 51:</b> High-Arrestance Bag Filter . . . . .	97

# 1. INTRODUCTION

---

Though control of indoor air pollution at source is the first priority for healthy indoor environments, the heating, cooling, ventilating, humidity control and air cleaning systems in homes also play a major role. While, ideally, these systems are part of an air quality solution, they can also produce air quality problems if not carefully chosen, installed and maintained. This document

presents mechanical strategies for healthy indoor environments which avoid many of the problems and limitations often associated with typical systems. It also provides practical, appropriate mechanical solutions for the environmentally hypersensitive for both new and existing housing. The term "environmentally hypersensitive" refers to those persons who are more reactive than the general population to typical air pollutants and water contaminants, and may experience mild to severe symptoms if exposed to low levels of contaminants. Clearly, the indoor air quality requirements for some are far more rigorous than for the general population.

Solutions to achieving good indoor air quality cannot be considered in isolation. The use of mechanical equipment for heating, cooling, ventilation and air cleaning is part of the house-as-a-system approach to air quality which stresses source and moisture control, the building insulation, air barrier, vapour barrier and other building components in conjunction with the heating, cooling, ventilating and air filtration systems. It also includes fireplaces and other important elements. In many cases, one element cannot be separated from another, because there are compatible and incompatible combinations. For this reason, this document begins with a discussion of common heating and ventilating system types as they are used in Canadian homes, rather than a discussion of the components alone. The role of source and humidity control, and air barriers in relation to the mechanical equipment is also emphasized. These mechanical systems represent the more common combinations of equipment used across Canada. An introduction

to equipment, emphasizing its impact on indoor air quality, follows the systems discussion. Equipment performance and applications are then summarized in the equipment reports. These should always be used in conjunction with a whole system approach.

A good example of the importance of the house as a system is the difficulty experienced in retrofitting ventilation equipment in older homes. Effective ventilation requires a degree of control over the building envelope, but due to higher air leakage rates, accumulated dust and debris, existing furnaces and fireplaces, and other problems, it is difficult to control airflow, air pressure and air quality in older homes. For example, adding a large kitchen range exhaust and draft sealing to an existing home may cause the furnace and fireplace to leak hazardous combustion gases into the home. It may also cause dust to enter through cracks in walls and ceilings. The selection of appropriate retrofit methods for improving air quality in older homes is, therefore, perhaps even more critical than in new homes. At the same time, carefully considered heating and ventilation retrofits are often the most cost-effective and practical means of solving air quality problems in existing homes. Retrofits have the potential to improve living conditions for far more people than new construction. For this reason, there is special emphasis on retrofits in this document.

## How to Use the Guide

The guide is divided into several parts beginning with an introduction and discussion of heating, cooling, ventilating and air filtration principles and systems in homes. Unless you are very familiar with mechanical systems and air quality problems in housing, you should start by reading the discussion of the general principles. After this, you may wish to refer to the system which is closest to the one of interest to you. If you are considering retrofits to an existing home, refer to the section dealing with retrofits. *If you are*

*dealing with environmental hypersensitivity in the household, you will need to consider the special requirements for those circumstances.* Discussions pertaining to the environmentally hypersensitive are in italics.

Once you understand the basics, the characteristics of your system and any special requirements, you should then refer to the specific equipment used in the system you are considering. The generic product or equipment reports which form the heart of the document will give you information on the following aspects of each equipment type listed:

- common product names;
- typical system application;
- description;
- installation considerations and options;
- general and specific health issues associated with this equipment;
- a notation if the equipment has special indoor air quality merits;
- comments from expert reviewers about this equipment;
- typical maintenance requirements;
- typical operating costs;
- sources for this product; and
- cross-references to other products associated with the equipment.

Once you have determined that a particular piece of equipment may be appropriate for your situation, you may wish to refer to the list of product suppliers, by category, in the back of the volume. Supplier listings are either for a Canadian distributor or the manufacturer. By calling the telephone number with the listing, you can find the dealer nearest you. The supplier listings are not exhaustive. Your local mechanical contractors, heating and sheet metal suppliers, other specialty suppliers and building consultants will often have information on products not listed in this section. Remember, the reports are generalized for the class of equipment. There may be individual variations among models and manufacturers which are also important to you.

If you need information on portable heaters, room air cleaners or water purification units only, you may wish to go directly to that section in the main body of the reports. It is entirely self-contained.

## 2. THE HOUSE AS A SYSTEM

Heat, moisture and air movement in buildings is interrelated—one element cannot be changed without affecting the others. The movement is influenced by the weather, the occupants, the mechanical systems in the house and the construction of the building envelope. The interactions affect the indoor air quality in the house. For this reason, the house as a system concept has been developed. When designing and building a home, it is important to understand these relationships. If this is not done, unexpected and often negative results can occur. Below are principles of the house as a system.

- To reduce operating costs, increase comfort and reduce interior condensation (which could lead to mold growth), insulation levels in exterior walls, floors and ceilings are increased beyond code minimums.
- Higher insulation levels will increase the likelihood of condensation forming inside insulated wall and ceiling cavities, if there is the movement of airborne moisture from the heated space into those cavities during the heating season. Accumulated moisture can lead to rot, mold growth (potentially affecting indoor air quality) and reduced insulation performance (Figure 1).
- With higher insulation levels, heat losses by conduction through the building shell are reduced, and air leakage now accounts for a larger proportion of home heating requirements. Typically, it increases from 30 to 50 per cent.
- To reduce heat losses by air leakage and control condensation formation in insulated cavities, a continuous air barrier

Figure 1:  
House as a System as Applied to Heating Climates—Step 1: Super Insulation, No Air Barrier

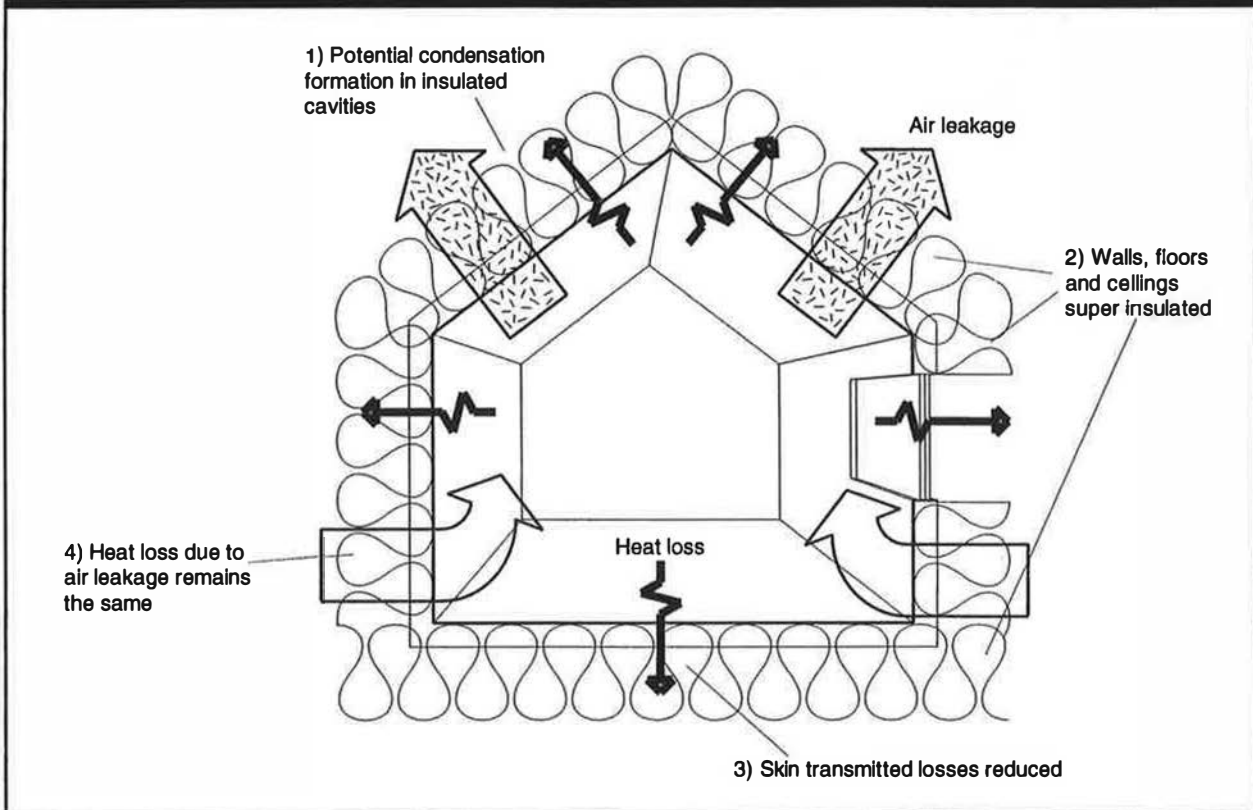

is incorporated in the insulated walls, floors and ceilings. This has the added benefit of reducing the entry of outdoor air pollution and air pollutants released from building materials inside the structural cavities (Figure 2).

- Incorporating a continuous air barrier in a home means that moisture and pollutants generated in the home remain there longer, unless a suitable ventilation system is installed and operated.
- Indoor air pollutants and, to some degree, moisture, are best handled through source control. Careful selection of low-emission materials, use of sealed combustion or induced draft combustion appliances, and control of indoor moisture by moisture sealing basements and other sources are first steps.
- The moisture and indoor pollutants that cannot be reduced or eliminated by source

control can be removed and diluted by a continuously operated, distributed ventilation system. Since natural ventilation is random, and driven largely by weather conditions, mechanical ventilation is considered the most reliable (Figure 3).

- The operation of a continuous mechanical ventilation system increases energy consumption for heating and cooling. This is due to the fact that the air which is exhausted from the home is replaced by outside air that must be either heated or cooled. For maximum efficiency and increased comfort, a heat recovery ventilator is recommended (Figure 4).

**Indoor air quality strategies: prevention is the best cure**

The primary indoor air quality strategy is to prevent problems at their source rather than try to solve them by ventilation. For example, preventing air contaminants from entering the

Figure 2: House as a System as Applied to Heating Climates—Step 2: Incorporation of a Continuous Air Barrier

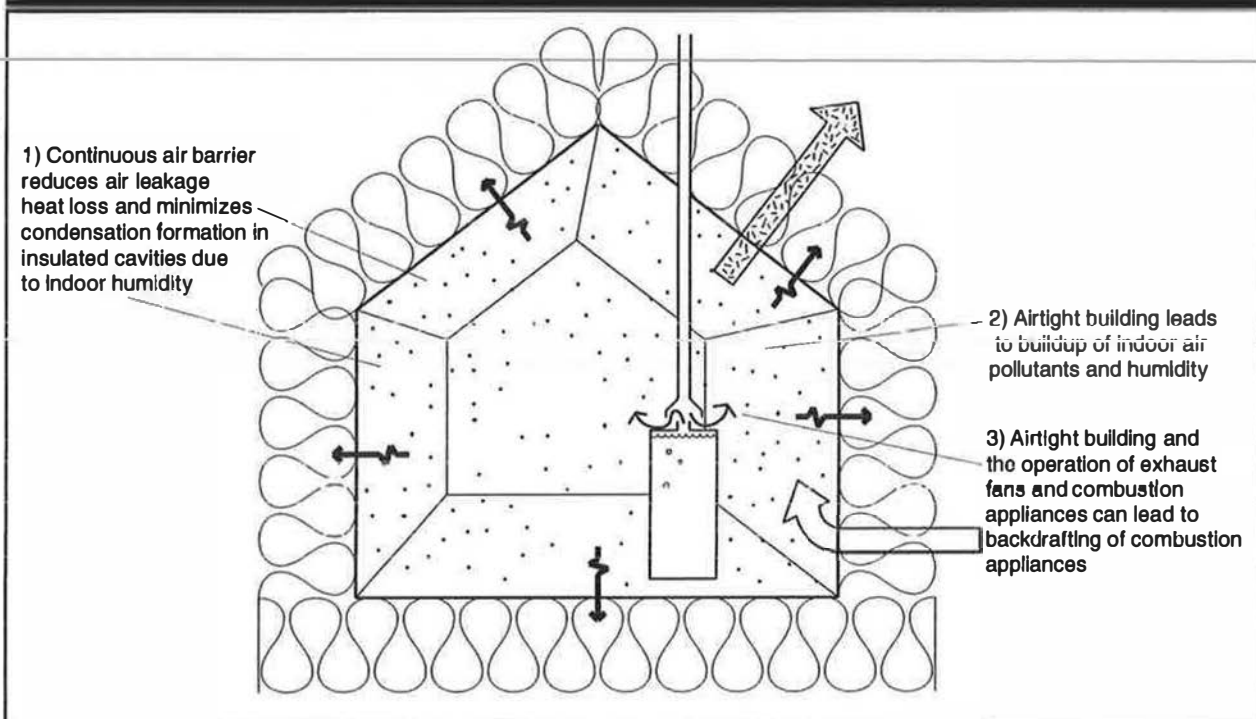



**Figure 3:**  
House as a System as Applied to Heating Climates—Step 3: Ventilation and Pollutant Source Control

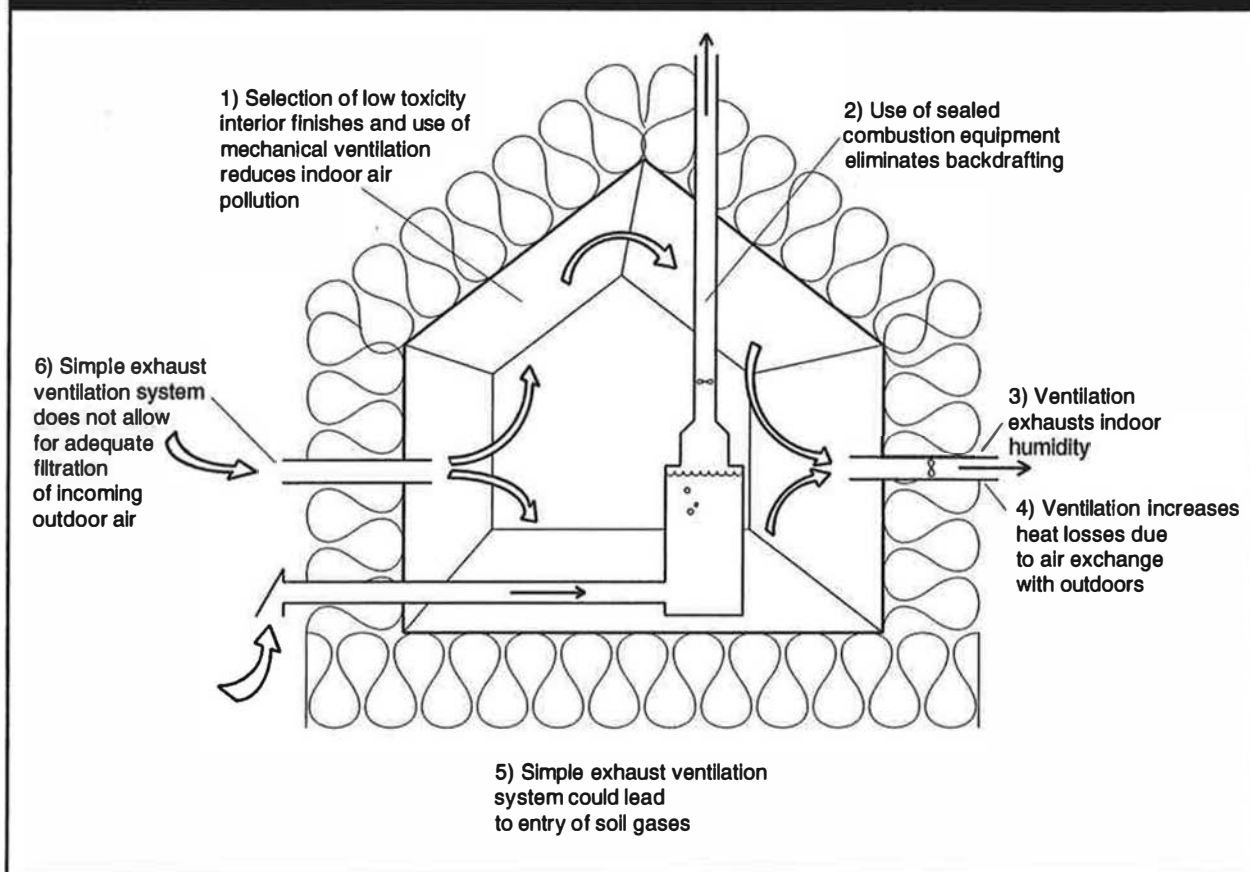

home is always more effective than diluting them by ventilation or attempting to remove them by filtration. Although this document emphasizes mechanical systems, prevention strategies should already have been applied in order for the systems to be effective. For further information on prevention measures, refer to other CMHC documents (*The Clean Air Guide; This Clean House Video; Building Materials for the Environmentally Hypersensitive; Investigating, Diagnosing and Treating Your Damp Basement*).

**Selection of low toxicity finishes and furnishings**

Some indoor air pollutants come from building materials, furnishings and consumer products. Those sources which are present in large amounts, such as vinyl floorings and carpets, or wood

composition boards containing formaldehyde-based adhesives, are the most significant sources of gaseous pollutants. Textile materials, such as carpet, upholstery and draperies, are also substantial sources of dust. They trap odours from other sources and are breeding places for bacteria, dust mites and molds. Careful selection of stable, low-toxicity and dust-free materials is an important aspect of prevention at source. For more information on materials and finishes, see the CMHC document *Building Materials for the Environmentally Hypersensitive*.

**Prevent conditions which support fungus and bacterial growth**

Microbial contamination can be best prevented by avoiding moist conditions where nutrients, such as dirt, dust and skin, are present which could support fungus or bacteria. Common

**Figure 4:**  
House as a System as Applied to Heating Climates—  
Step 4: Balanced Heat Recovery Ventilation

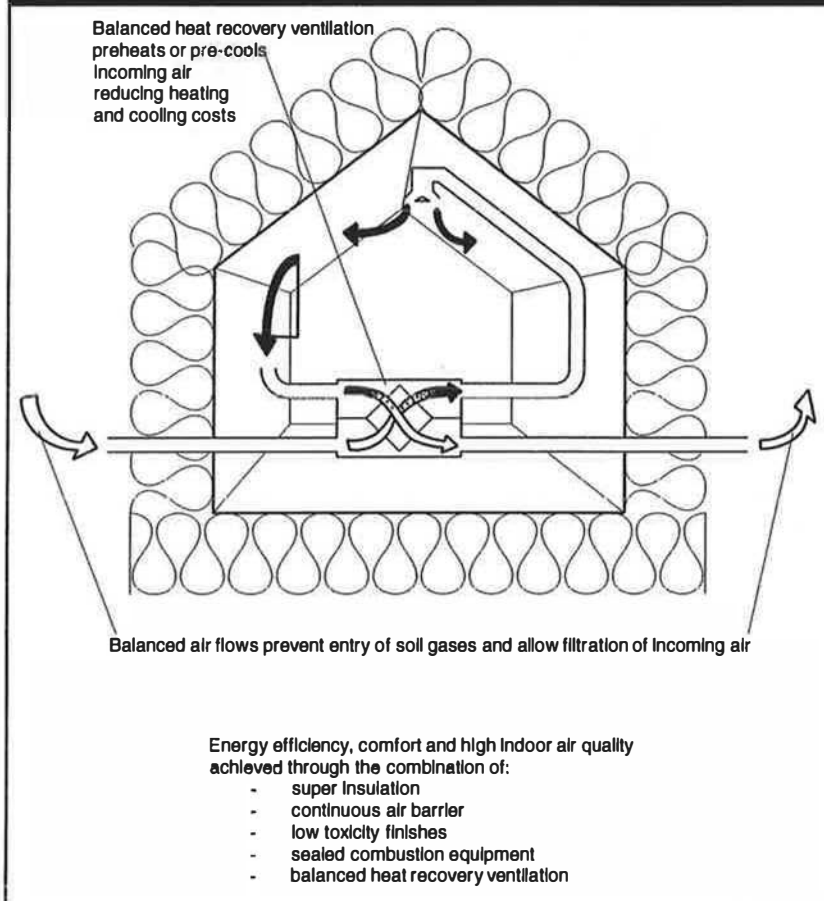

exhaust dangerous combustion gases and a supply of air for combustion. The effective operation of conventional chimneys for fuel-burning devices can be easily overcome by strong winds or large exhaust fans which depressurize the home or chimney obstructions. Improved combustion equipment is isolated from the home by drawing combustion air through a duct and discharging exhaust gases through an airtight flue—this type of equipment is not prone to dangerous failures. Gas ranges also introduce hazardous combustion gases into homes which cannot be perfectly vented by the best exhaust fan.

**Seal out soil gas**

Radon and other soil gases are health risks in homes in some areas in Canada. They can enter through cracks in basement walls, floors, drains and sumps. Where soil gases are known to occur, it is important that routes

examples are soiled carpets in moist areas, damp basements and closets, soiled or faulty humidifiers, moist woodwork such as window sills, cracks in tub and shower enclosures, and porous surfaces or cracks in kitchen work areas. Durable, non-porous materials are the best prevention in moist areas and where soiling will occur, such as showers, baths and kitchens. To prevent condensation from occurring, proper insulation and ventilation are important. In some climates, dehumidification may be necessary to prevent excess moisture buildup in summer. Proper drainage of the foundation will reduce the entry of water into basements.

**Isolate combustion appliances from indoor air**

Furnaces, water heaters, fireplaces and fuel-burning heaters all require reliable chimneys to

of entry are sealed as much as possible, and that heating and ventilation systems are designed to reduce soil gas entry by maintaining the pressure balance.

**Seal out outdoor air pollution**

In some locations, air pollutants in homes come from outside. Common examples are dust, automobile and industrial emissions, and urban smog. At certain times of the year, pollens make their way inside and affect sensitive individuals. It is important to reduce entry of these contaminants by weather-sealing windows and doors, and locating air intakes for ventilation equipment in the least affected place.

**Seal out gases and dust emitted by building materials**

For pollutant sources such as insulation in walls and ceilings which cannot be avoided, the best prevention is to seal them in place. The use of a continuous air and vapour barrier for wall and ceiling construction is an example of sealing out a source of dusts and gases.

**Important lifestyle choices**

Smokers in the household, pets, hobby activities, storage of hazardous materials, and cleaning and maintenance methods are also very important sources of indoor air pollutants. These are largely lifestyle choices made by the occupants which have a major negative impact on the indoor air quality.

## 3. HEATING AND COOLING

---

### Energy Sources

#### Natural gas

Natural gas is the preferred heating fuel in many Canadian regions where it is available. It is a low-cost and reliable fuel which is primarily composed of methane with small amounts of other gases. A potent odourant is added to make gas leaks detectable. *Many environmentally hypersensitive persons must avoid gas installations in the home due to the risk of small leaks and flue gas spillage. If gas is used, a gas-fired boiler should be chosen. These boilers should be either a sealed-combustion type or located in a separate boiler room, preferably accessed from the outside.*

*Open gas ranges, gas space heaters and gas clothes dryers are definitely not recommended for the hypersensitive.*

Natural gas is an odourless fuel; however, the odourant added is made from methyl, ethyl and butyl mercaptan compounds containing sulphur. These are very potent irritants and exposure to tiny amounts may cause severe reactions in the hypersensitive.

#### Propane

Propane is commonly used as a heating fuel in rural locations where natural gas is unavailable. It is primarily composed of propane and butane gases with the addition of the same odourant used in natural gas. The advantage of propane is that it can be easily liquefied for transportation and storage, while natural gas cannot. Generally, most natural gas-burning appliances can be fuelled by propane with minor modifications, so the same systems and equipment are applicable.

*Though propane is chemically quite different from natural gas, the concerns with propane and natural gas are every similar. The explosion risk and irritant nature of the odourants are the major concerns.*

#### Fuel oil

Home heating oil is a traditional heating fuel in many parts of Canada, though it is rapidly being replaced by natural gas as it becomes available. It is composed of light petroleum distillates containing small amounts of aromatic compounds and sulphur. Because supplies are perceived to be limited, there has been a national program to replace heating oil.

*Oil has a strong odour which many people find objectionable. Delivering and handling oil can cause small spills. Oil burners can leak, leaving oil-saturated floors in basements. The residual odour from oil leaks can last several months or years. It burns with a great deal more residue than other fuels. Oil burning typically produces some smoke and soot, as well as sulphur oxides.*

#### Electricity

Using electricity directly as a heat source is not preferred from an environmental or a utility management standpoint in many regions of Canada. This is because electricity is a high-quality form of energy that can do many useful things. Heating is a low-quality use. If the electricity source is a coal-fired or nuclear plant, less than one third of the fuel used is converted to useful electricity. However, in British Columbia and Québec, where most of the electricity is hydro-electric, there is a good deal of electric heating done. Generally, a heat pump is a more appropriate way to use electricity for heating because it is two to three times more effective than electric resistance heaters.

Electricity is a clean fuel from the standpoint of occupant health because it requires no fuel handling and no on-site combustion. However, in regions with thermal generating plants, it is a serious regional pollution concern. Concerns about exposure to low-frequency electromagnetic fields from electrical appliances in the home are also emerging, but this area is in its infancy and poorly understood.

## Wood

A substantial amount of wood heating is done in Canada, particularly in small towns and rural areas. Though wood is a renewable fuel with minimal environmental impact, many woodburning appliances are very inefficient and produce substantial air pollution. The problem is so serious in some colder regions that restrictions on burning are applied.

Burning wood in all but the most efficient appliances produces smoke, soot, ash and aromatic hydrocarbons. Most are serious local air pollutants and some are carcinogenic. In areas with a great deal of woodburning, the health effects on the population are a serious concern. *Many houses for the hypersensitive do not include woodburning appliances. If they are included, they usually have outside air supplies, tight chimneys and meet low-emission wood heater listing requirements. To reduce flue emissions, some have catalytic converters and draft fans which require regular maintenance. Conventional open fireplaces of any kind are not recommended due to the difficulty in preventing entry of flue gases and soot into the home.*

Woodburners meeting CSA B415.1-M92 "Performance Testing of Stoves, Inserts and Low to Medium Burn Rate Factory Built Fireplaces" or the United States Environmental Protection Agency (EPA) woodburning appliance standards (1990), CFR Part 60, are lower-emission units if operated correctly.

## Furnace Types Based on Fuel

### Gas furnaces

This classification of furnaces also applies to boilers and domestic hot water tanks.

#### Naturally aspirated

Naturally aspirated gas or propane furnaces rely on the natural buoyancy of the heated flue gases for venting. They draw air from the house for combustion. Dilution air is brought in through

a draft hood, primarily to isolate the burner from changing outside pressure conditions at the top of the chimney. Their efficiencies are typically around 65 per cent.

Because the burner is open to the home interior, these units are prone to flue gas spillage (backdrafting) when other combustion appliances and exhaust fans are operating. Naturally aspirated gas furnaces also have a pilot light which is a source of unburned and combustion gases.

The primary heat exchanger is usually a set of tubes or channels fabricated from welded steel. The combustion process occurs inside the channels and the air from the blower is passed directly over the outside of them (Figure 5). The primary heat exchanger must operate at high temperatures to prevent condensation from accumulating on the metal parts and to boost flue gases up the chimney.

#### Mid-efficiency furnace (induced or forced draft)

The mid-efficiency furnace usually has an induced-draft fan located in the exhaust flue to control the flow of gases through the furnace (Figure 6). Combustion air is drawn from the home and the flue fan forces the combustion gases out through the flue. The furnace resists flue gas spillage (backdrafting) more effectively than naturally aspirated units, but does not eliminate backdrafting. Forced-draft systems with power burners, commonly used in boilers, perform similarly.

No draft hood is needed. Due to the lack of dilution air, the amount of gas flowing through the venting system is less. The reduced flow and lower flue-gas temperatures can cause the flue gases to condense in the furnace or venting system. Condensation is reduced by using a double-walled connector and chimney vent, both sized to the reduced gas flow.

Instead of venting through the roof, the flue is often vented through the wall. Due to major problems associated with the plastic vent and

Figure 5:  
Forced Air Heating System with a Naturally Aspirated Furnace

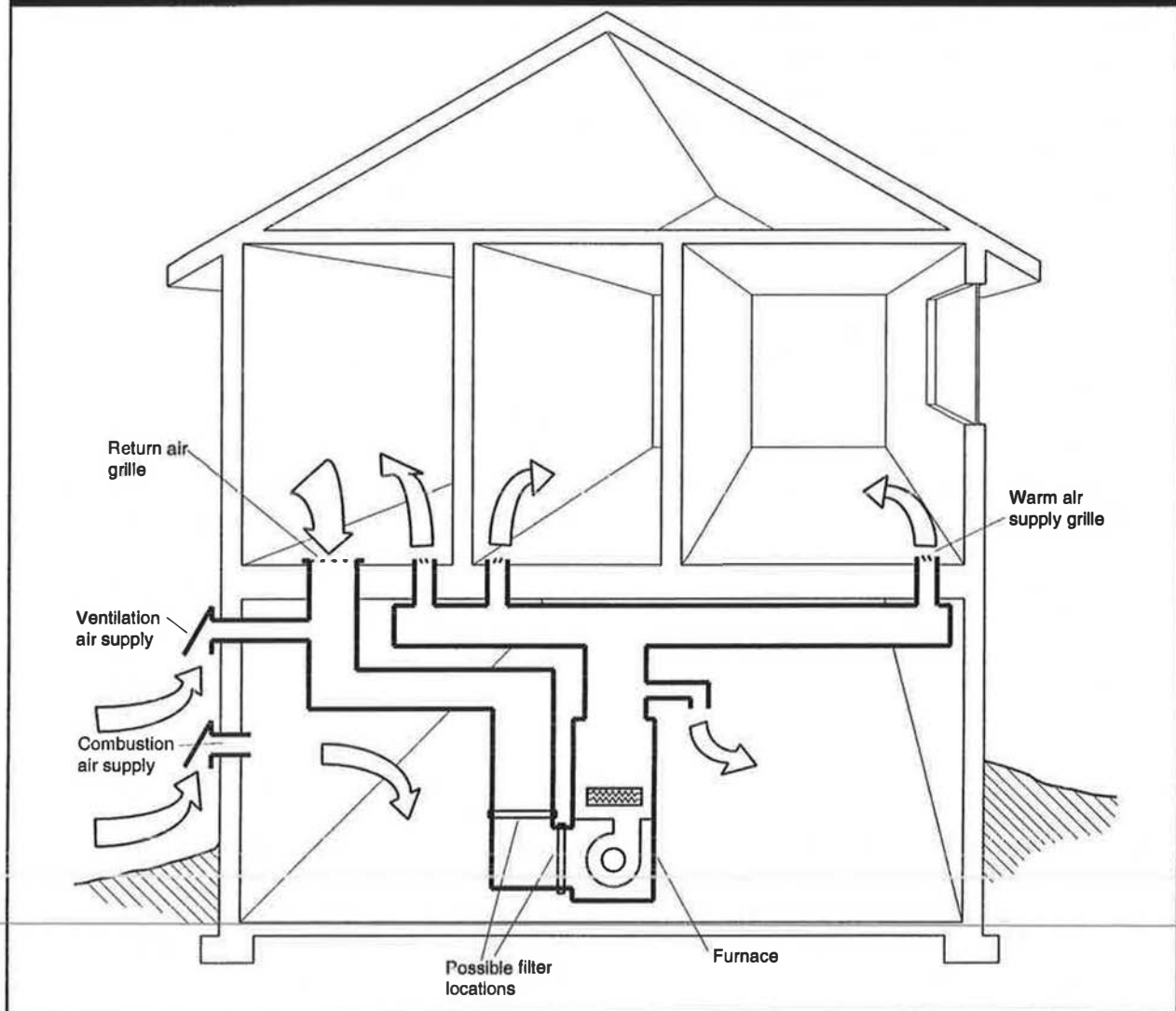

sealing of the joints, new installations using wall vents are prohibited.

The heat exchanger for a mid-efficiency furnace is similar to that of a naturally aspirated furnace. It may have a pilot light or electronic ignition. Efficiency is around 78 to 83 per cent.

#### *Condensing gas furnaces*

A condensing gas appliance has a very efficient secondary heat exchanger which cools combustion gases to the point where water vapour is condensed from the flue gases (Figure 7). Condensing gas furnaces usually have

sealed or combustion chambers, so the risk of combustion gas contamination of the home is very low. These operate with efficiencies of 90 to 95 per cent and often use plastic (ABS or PVC) piping for combustion air supply and flue gases. Since they incorporate a flue fan, the flue can be run a longer distance than with conventional combustion equipment.

A high-efficiency condensing furnace extracts more heat from the flue gases through a secondary heat exchanger. The secondary heat exchanger is designed to drain off the condensation that occurs when the flue gases are cooled more completely. The heat

Figure 6:  
Typical Gas Induced Draft furnace

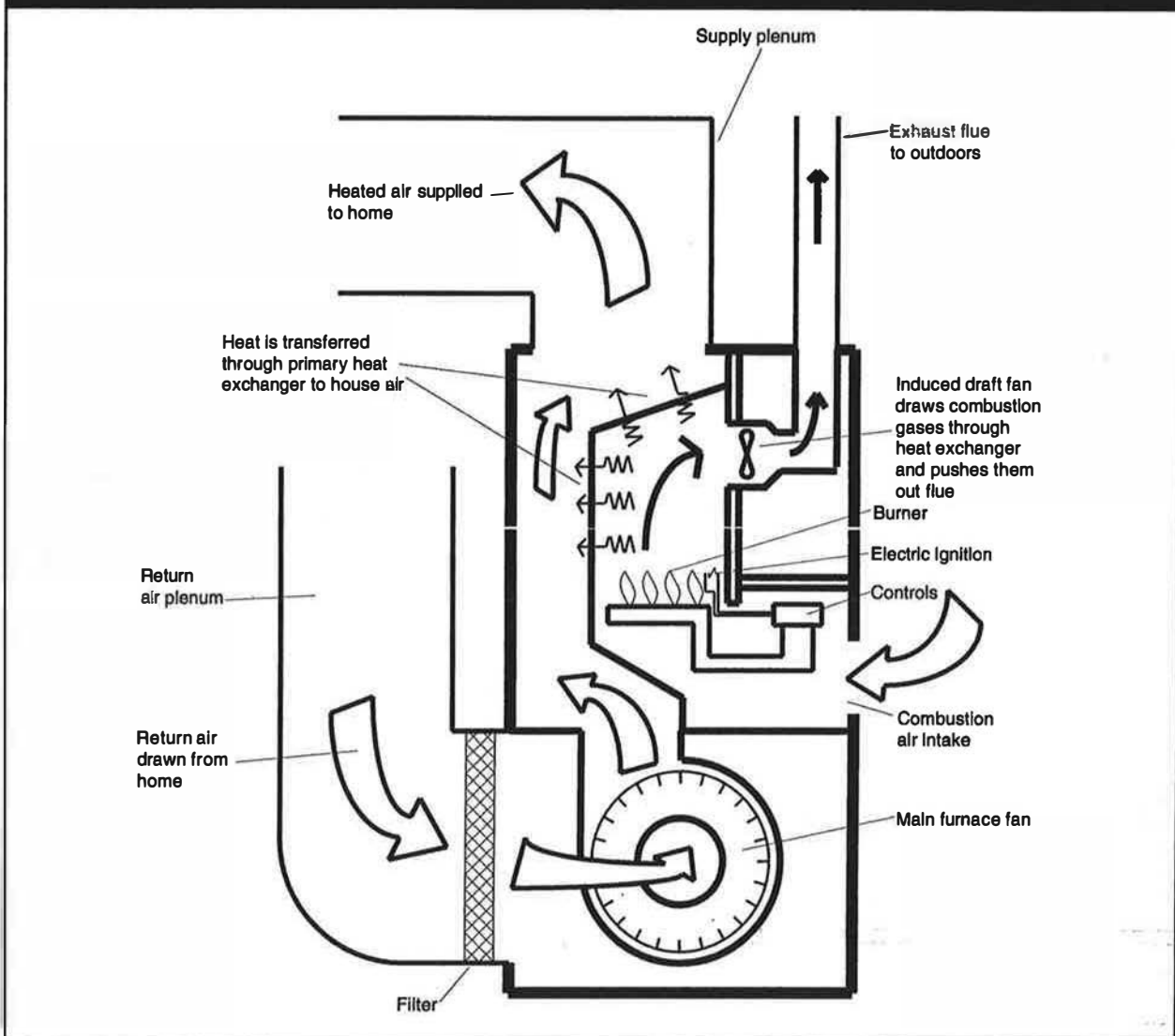

exchangers are constructed of corrosion-resistant materials, such as stainless steel, to prevent corrosion damage. They are often equipped with a small flue fan to aid venting of flue gases. Instead of a conventional chimney, combustion gases may be exhausted through plastic piping (Figure 7).

### Oil furnaces

#### Conventional oil furnace

Conventional oil furnaces are naturally aspirating and depend on a damper to create a draft to carry

the combustion gases up the chimney. They are prone to spillage during start up and shut down of the oil burner.

Furnaces with high-efficiency, flame-retention head burners give fuel savings of 15 to 20 per cent compared to conventional cast-iron head burners.

#### Mid-efficiency (forced or induced draft)

A mid-efficiency oil appliance effectively eliminates the damper. It may have an induced-draft fan which pulls the gases through the

Figure 7:  
Sealed Combustion Condensing Gas High-Efficiency Furnace

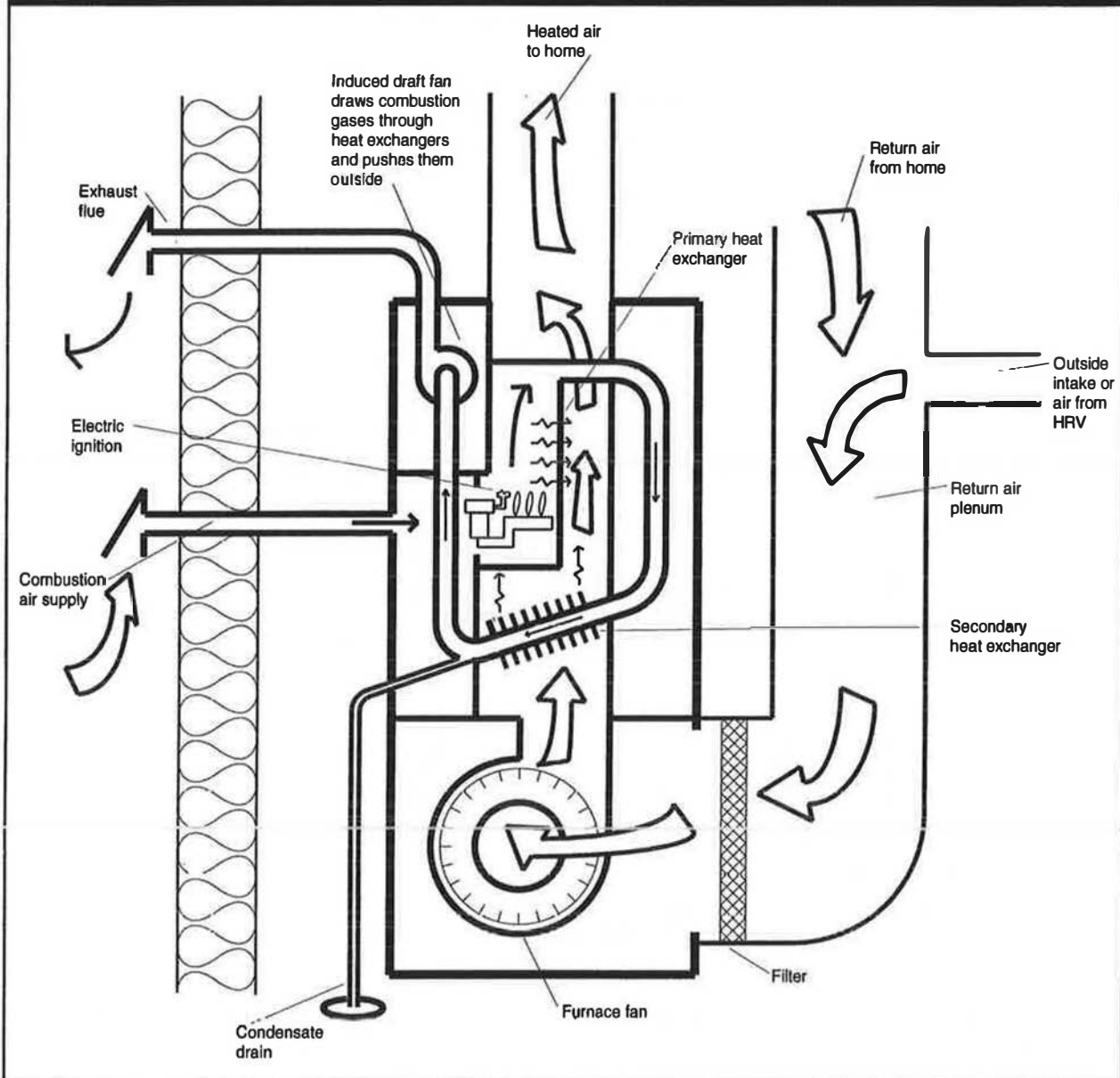

furnace and propels them up the stack or out the side wall of the house. It may be a forced draft where a high-static, pressure-drop burner is installed in a properly baffled furnace, allowing the burner to withstand any pressure fluctuations transmitted from the top of the stack. Fuel savings and emission reductions are about 25 to 30 per cent compared to a conventional furnace.

#### *Condensing oil furnace*

An additional heat exchange section, made of stainless steel or plastic with a water spray, extracts the latent heat from the water vapour produced in the combustion process. However, since less water vapour is produced by the combustion of oil compared to natural gas, the potential for efficiency improvements by



condensing the flue gas from oil is much lower. The condensate is also very corrosive, and soot can be deposited on the heat exchange surface. Condensing oil furnaces have efficiencies that range from being somewhat less efficient than the better mid-efficiency types to eight per cent higher.

Due to the higher costs and potential corrosion of condensing oil units, mid-efficiency oil furnaces are preferred. Oil-condensing units are not recommended at present.

### **Electric furnaces**

Electric forced air furnaces use heating coils made of resistance wires similar to toaster or electric range elements. Electric hot water tanks are widely used. Electric boilers are available.

### **Forced Air Systems**

A forced air system is a heating or cooling plant which recirculates house air. The basic components are a fan, a burner or other heat source, a heat exchanger, supply ducts, grilles or diffusers, a return air path and controls. The common optional components are a cooling coil, air filtration, humidification, an outside air supply and zone controls to allow heating or cooling of individual parts of the house. Though a forced air system can be an appropriate choice for good indoor air quality, not all heating plants are alike (Figure 5).

#### **Heating plant**

Heating plants are fuelled by natural gas, propane, fuel oil, electric or wood heat. In some areas, dual-fuel systems such as oil and electricity are installed. Due to its moderate installation cost and simplicity, a conventional gas-fired forced air furnace is the most common heating plant in Canadian housing where natural gas is available (Figure 6). However, it is not the preferred unit for indoor air quality since it may release combustion products into the house.

An alternative type of heating plant contains a boiler and an air handler called a fan coil. The

source of heating or cooling is a boiler, hot water heater, heat pump or an energy recovery or storage unit. A fan coil has significant advantages for indoor air quality because the heat exchange temperature is lower and any fuel burner involved can be isolated from the home. See the fan coil section for more details (Figure 8).

#### **Cooling plant**

Virtually all residential cooling plants are electric motor-driven refrigeration units. The major component, incorporating a compressor, condenser and cooling fan, is generally located outdoors in a weatherproof cabinet. A refrigerant, circulated by the compressor, extracts heat from house air through a coil mounted in the airstream and discharges it outdoors through the outside condensing coil. Because cooling of air also reduces its capacity to hold moisture, a cooling unit will also dehumidify indoor air. This moisture will accumulate as condensate on the expansion coils in the fan coil and must be collected and drained away. Trapped moisture in cooling equipment is a serious health risk since it acts as a growth medium for bacteria and fungi.

Heat pumps are primarily designed for heating homes but may also function as cooling plants when their operation is reversed. Heat is extracted from outdoor air or groundwater and discharged into the house air through a coil. Heat pumps can also be designed to have their cycles reverse automatically for summer cooling. See the heat pump/air conditioner section for more details.

#### **Forced air furnace components**

##### *Furnaces*

Furnaces can be either fuel burning (combustion type) or electric. See the previous section for a discussion of the different furnaces.

Combustion equipment in the home produces hazardous combustion gases, gaseous residues from unburned fuel and, in some cases, soot. All are serious indoor air pollutants if allowed to enter the home. Reliably containing these

Figure 8:  
Fan Coil System

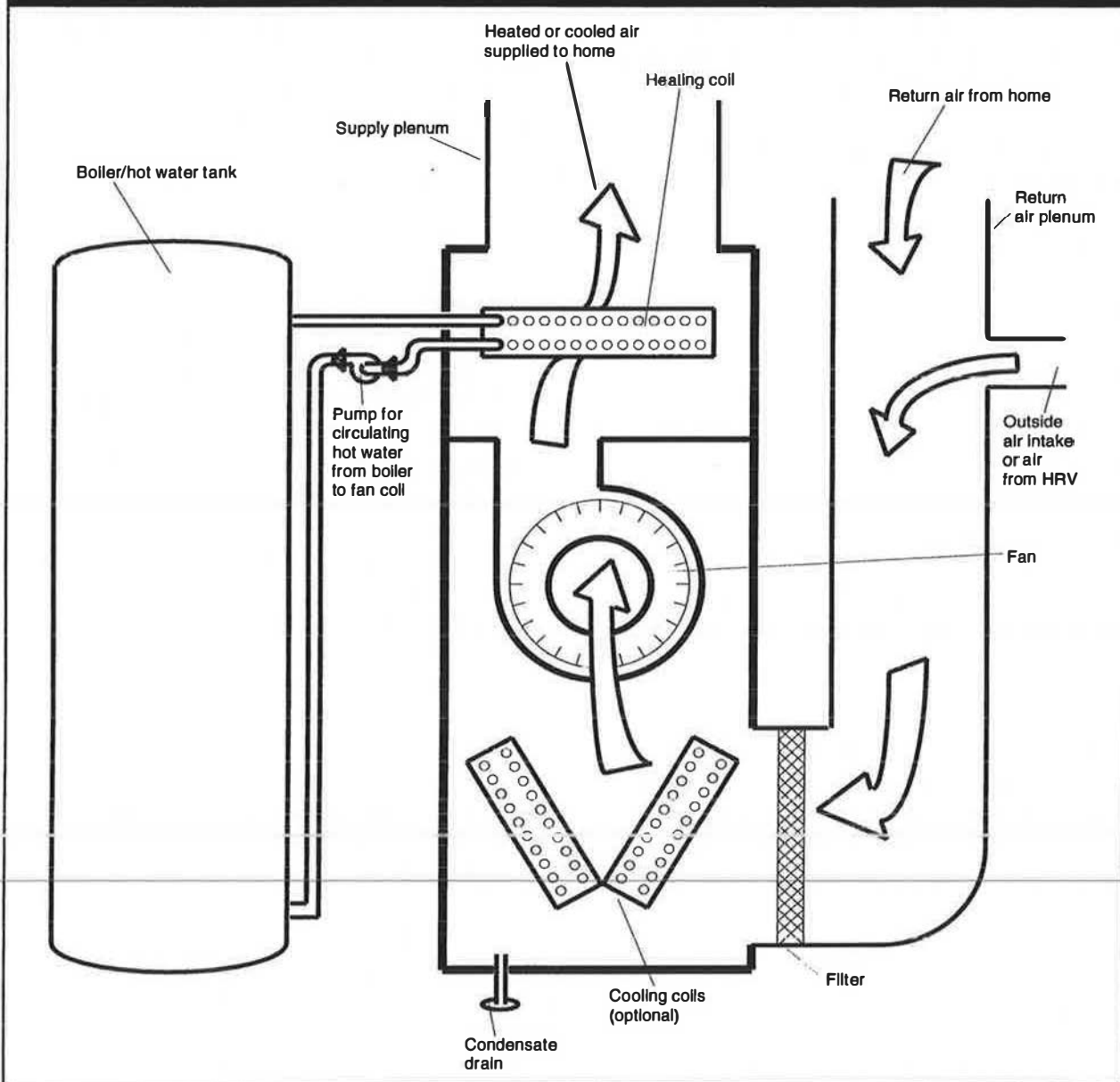

within the combustion chamber and venting them outside is therefore an essential indoor air quality strategy.

**Fans**

Furnace fans are universally squirrel-cage type blowers made from slotted steel cylinders (figures 6 and 7). These are more effective and much quieter than propeller-type fans. The blower may be belt-driven by a separate motor, or it may

be a direct-drive type. The blower speed is controlled by changing the size of the belt pulley or by electrically switching the motor. Most motors are designed with an open frame with the internal windings and moving parts exposed to the airstream. The parts are coated with varnish and oils that can be sources of air contamination. Household dust also lodges in the motor and is heated when the motor is operating. One advantage of belt-drive motors is that they can be replaced with totally enclosed (TEAO,

TENV or TEFC) motors. Belt drives are intrinsically more noisy. These motors have windings and internal parts that are completely sealed from the airstream thereby reducing air pollutants.

The supply-air fan in the traditional natural-draft, forced air furnace is operated by a fan control which starts the fan only after the heat exchanger has warmed up. The fan is also stopped before it completely cools down. This ensures that the air delivered to the house is usually warmer than body temperature, and will rarely cause discomfort complaints, even when the airstream blows directly on people. This traditional fan control method is less common in recently constructed houses because the furnace usually has a continuously operating fan. In these systems, the fan is operated at a lower speed to improve heat and air distribution and to provide better ventilation and air filtration.

When a boiler and fan coil heating system are used, the delivered air temperature may sometimes be less than skin temperature and cause comfort complaints. This may also occur with a burner-type furnace when cold outdoor air is mixed with recirculated air when the fan is operating but the burner is off. Given these conditions, which commonly occur in contemporary forced air designs, the preferred approach is to locate the warm-air supply registers so they do not flow directly onto room occupants.

Several sophisticated furnaces and fan coil units now use electronically controlled permanent magnet motors. These are often called electronically commutated motors and are capable of an almost infinite speed range variation while maintaining high efficiency. Use of these motors allows optimum control over heating and cooling efficiency, comfort levels, noise and fan energy consumption when used with the appropriate control systems.

### ***Filters***

Furnace filters are normally located where the return air enters into the furnace cabinet

(Figure 6). The filters normally supplied with the furnace are primarily intended to reduce the accumulation of dust on the heat exchanger, blower motor, fan wheel and supply ducts. Many types of improved filters are available which can be added to, or used in place of, standard furnace filters. These remove fine dust and odours.

### ***Supply and return ductwork***

Air from the furnace is delivered to the rooms of the house through supply ductwork. While supply ductwork in most Canadian homes is constructed of galvanized steel sheet, any durable material that is non-combustible and corrosion-resistant such as aluminum, copper, clay or concrete may be used. Ducts should be made of non-absorbent, durable materials since dust collection, mold build up or odour absorption are less likely. The authoritative source for the design and layout of conventional heating and cooling duct systems is the *HRAI Residential Air System Design Manual*. The design of the supply ductwork can have a strong influence on the balance of air supply between rooms. The system must be designed so heat flow to the rooms balances heat losses from the rooms and, if the same system is used for cooling, it will often be necessary to adjust the airflow rates for cooling operation. Ductwork should have balancing dampers at each split or duct take-off to allow proper balancing. Furthermore, the ducts should be accessible for cleaning and designed to minimize the trapping of dust and debris.

Air is returned to the furnace via a return air path or return ductwork. Though some furnace units are located in a closet and require minimal return air ductwork, most conventional designs require ductwork across the house and from upper floors where the air is returned through grilles. In some new systems, the return grilles are located near the ceiling, as high as possible in the house, to improve heat distribution and comfort.

The construction of the return ductwork is significantly different from the supply air ductwork because air is handled at a lower temperature and fewer return points are

required. In many homes, interior wall and floor framing cavities have been blocked off with wood and sheet metal and are used as returns. In these situations, the wood studs or joists, gypsum wallboard or wood sub-floor form the walls of the duct. Return duct design is very important for indoor air quality, not only for comfort and efficiency, but because accumulated dust and debris in ducts are an important source of indoor air contamination. These ducts also tend to draw in contaminated air from crawl spaces and insulation cavities. In some carefully designed houses using forced air systems, all return-air ducts are lined with sheet metal and sealed so they tend to accumulate less debris and are more easily cleaned.

### ***Grilles, registers, diffusers***

A grille is a slotted plate with no adjustment which is most often used for return air. A register is a plate with an adjusting damper which helps control air volume and sometimes, air direction. Registers are commonly used for heated supply air in floors and sometimes for wall and ceiling applications. A diffuser is a round or rectangular fixture designed to project air into the room in a specific pattern. Diffusers are most commonly located in ceilings and walls, and used for ventilation or cooling supply air. The location of registers and diffusers must encourage a good air mixing pattern in the room while providing comfort. This is usually achieved by locating the air-supply point as far away from the air-exit point as possible, and ensuring that air is not blown directly onto people.

### ***Humidification***

Humidification is often important in colder regions where winter dryness is a problem. A traditional method for forced air systems is to use an add-on device, a humidifier which passes part of the airstream through an absorbent material that is moistened from a water reservoir. Some are simply switched on when needed, though a humidity control can also be used to provide humidification automatically.

The traditional types of residential humidifiers are prone to biological growth because they use tap water at room temperature and accumulate dust and debris which support bacteria and fungi. If humidification of a forced air system is necessary for health reasons in a very dry climate, then careful, regular cleaning and maintenance are essential.

### ***Heating and cooling controls***

The traditional basic control in a forced air heating system is a single, low voltage (24 volt) thermostat, located centrally in the house. More sophisticated thermostats are now available which control both cooling and heating functions separately and allow for control of the fan, independently of the heating or cooling function, while saving energy and money. Multi-stage thermostats are also available for some heating plants which can provide partial heating or cooling when the air temperature is fairly close to the thermostat setting. These improve the comfort and efficiency of operation.

Programmable thermostats are also now quite common in residential applications. These allow the temperature to be preset according to a 24-hour or seven-day program. This can provide energy savings (typically 10 to 15 per cent) through automatic setbacks during sleeping hours or when the house is unoccupied, as well as a morning warm-up period before sleepers rise.

Zoned control systems are also available for residential forced air systems, though they are uncommon. These provide automatic control of one or more rooms separately, using local thermostats and motorized dampers to direct air to the zones. Control systems can result in improved control for some home designs, as well as reduced equipment capacity, particularly for a cooling plant. However, the ability of the system to fully recirculate air throughout the house may be reduced when they are used.

### Integrating ventilation with a forced air system

Forced air systems are easily adapted to provide ventilation or assist in ventilating. There are generally two ways of doing this: add an outdoor air intake or integrate a heat recovery ventilator with the system.

#### Outdoor ventilation air intake

Perhaps the simplest ventilation arrangement that can be made is the addition of an outdoor air intake to the return-air ductwork of a forced air heating system. This approach is effective if the quantity of air introduced is not too large or the climate too severe. If too much cold air is brought in, there may be comfort complaints and a shortened furnace heat exchanger life. Furthermore, bringing in too much air can positively pressurize the house leading to excessive air leakage and possible moisture damage to the building structure (Figure 9).

In mild climates, it is adequate to control the outdoor airflow with a fixed damper in the duct. In colder climates, a variable damper and possibly a preheater may be necessary to protect the furnace heat exchanger from thermal damage and to provide comfortable air temperatures when the burner is off. If a whole-house exhaust fan is used and the furnace outdoor-air intake is the primary air supply to the house, the exhaust fan should be electrically interlocked with the furnace fan so it operates at low speed when the exhaust fan is on. This is a requirement of the 1995 National Building Code of Canada. See Chapter 4 for more details.

### Heat recovery ventilators

Heat recovery ventilator (HRV) systems can be easily integrated with forced air systems. HRV connections follow one of two main approaches: hybrid or simplified (Figure 10).

A hybrid HRV connection delivers outdoor ventilation air to the return duct of the forced air system and extracts exhaust from the kitchen and bathrooms through exhaust ducts. Outdoor ventilation air may be directly or indirectly ducted to the furnace return, depending on the type of system. Normally, there is no wiring interlock between the HRV and the furnace, so it is up to the homeowner to understand that the heating system fan must operate continuously in order to ensure distribution of ventilation air. The hybrid HRV connection provides the best combination of effective exhaust extraction from the house and preheating of supply air to the furnace.

Figure 9:  
Outdoor Air Intake Ventilation System

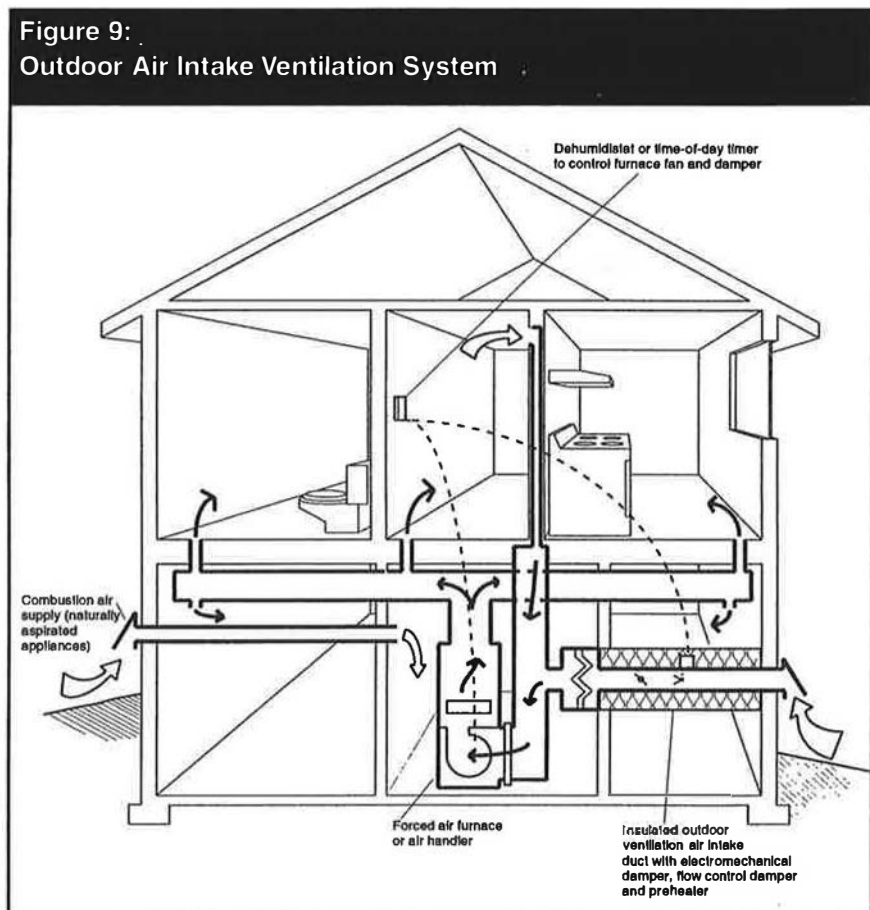

A simplified HRV connection extracts exhaust air from the furnace return ducts at one point and supplies air to the furnace ducts at another. Though these are less costly systems to install, they do not extract exhaust from the home as effectively as the hybrid system.

**General pros and cons**

Forced air systems are perhaps the most flexible type available for housing, and as such, are the

most common. They can heat, cool, humidify, ventilate and filter the air.

**Advantages**

- Moderate capital cost.
- Can provide ventilation.
- Can provide filtration.

Figure 10:  
Heat Recovery Ventilator Combined with Forced Air heating

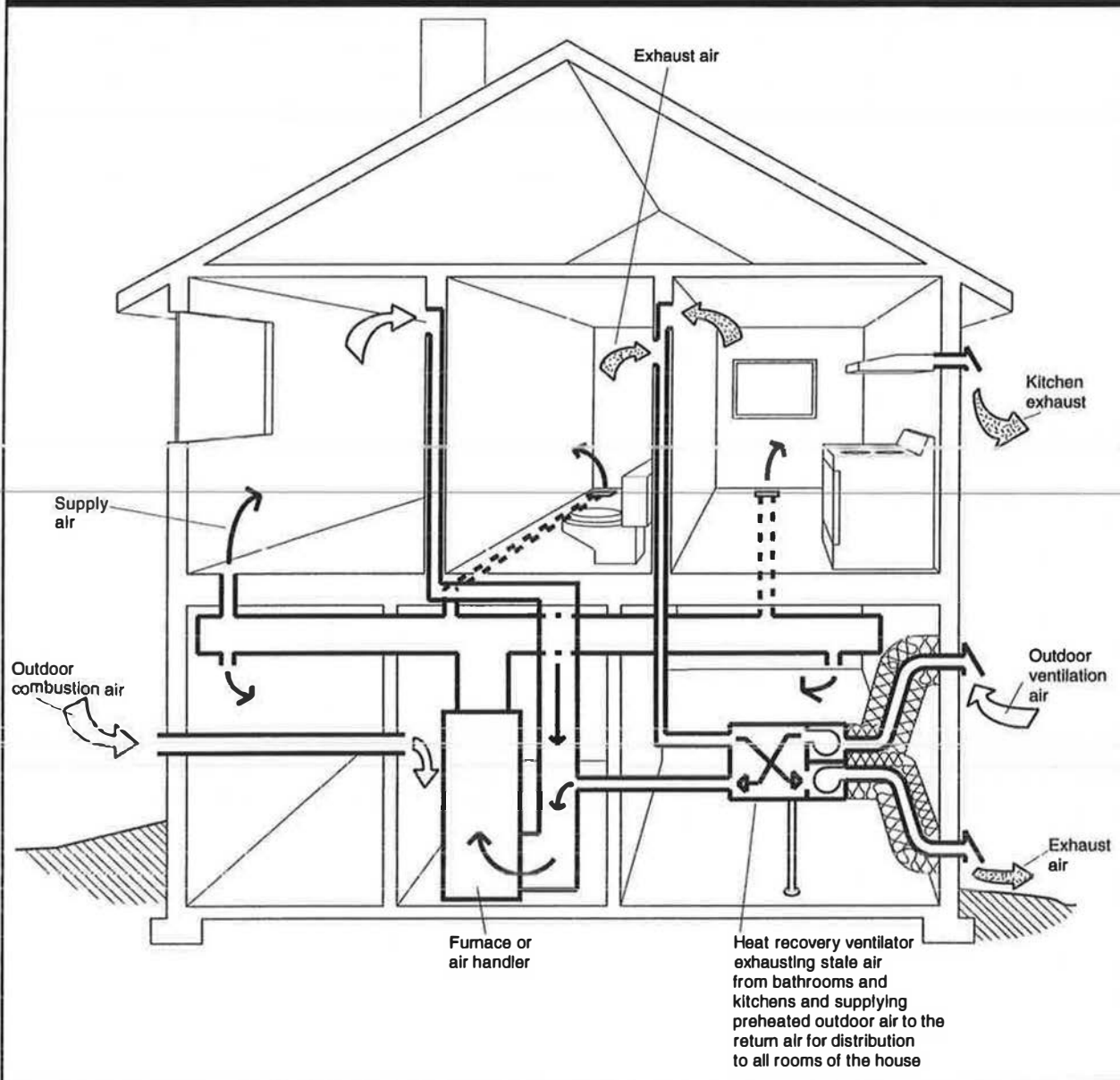

- Can provide cooling.
- Can provide central humidification.

#### **Disadvantages**

- May be noisy.
- Air movement may cause discomfort.
- Air movement stirs dust.
- Ducts accumulate dust.
- Space required for ducts.

#### **Capital costs**

Installed capital costs may range between \$3,500 for a simple forced air system with a conventional gas furnace to more than \$10,000 for a sophisticated fan coil system with a boiler and high-performance filtration. This does not include expensive equipment such as heat pump units.

#### **Operating costs**

Energy costs for any system are primarily determined by climate, building design and equipment efficiency. The most important equipment efficiency for a forced air system is the source of heating or cooling. Fuel-fired burners range from about 65 per cent efficiency for an older, conventional gas furnace or boiler to about 95 per cent efficiency for a condensing unit. The electrical efficiency of fan motors is also an important factor. An electronically controlled fan motor can be up to twice as efficient as a conventional permanent split capacitor motor. Fan motor operating costs can be a significant economic consideration if the central forced air system is operated continually in conjunction with ventilation.

#### **Maintenance**

Forced air systems require regular filter changes and occasional duct cleaning. If a fuel-burning

heat source is used, periodic burner inspection is recommended. If a heat pump is used, an annual inspection and cleaning of condenser and evaporator elements is recommended.

#### **Applications for the environmentally hypersensitive**

*Conventional forced air systems have a tendency to stir dust and produce odours from the high temperature heat exchangers. Furthermore, the fuel-fired furnace introduces risks of fuel odour, fuel leakage and flue gas spillage, all of which are serious health risks to most hypersensitive people. Forced air systems also mix air from all parts of the home, carrying cooking odours and pollutants throughout. This makes it very difficult to reserve parts of the house as sanctuaries for those with special air quality needs. For this, and other reasons it is common in homes for the environmentally hypersensitive to use a separate heating system, such as radiant floors or hot water hydronic heat, with a completely independent ventilation system which does not mix house air.*

*Though conventional electric resistance or naturally aspirated fuel-fired, forced air systems are not recommended for the hypersensitive, modified forced air systems using other heat sources can be very appropriate. Typical modifications are:*

- *A low temperature heat exchange unit (fan coil) is used in conjunction with a heat pump or boiler.*
- *Fuel-fired equipment completely separates combustion and flue gases from the occupied areas of the house, often enclosed in a sealed mechanical room, with a completely separate combustion air supply.*
- *High-performance air filtration is used.*
- *The fan motor is isolated from the airstream or is in a totally enclosed frame.*

- *All ductwork is cleaned before installation to remove oily residues.*

*Low-temperature heating coils are covered in this chapter. High-performance filtration is covered in Chapter 4.*

## **Fan Coil Systems**

Fan coil systems recirculate house air through heating and cooling coils which operate at moderate temperatures. Fan coils can provide heating only, cooling only, or both heating and cooling (though not simultaneously). Fan coil units typically are supplied with hot water or refrigerant from an external source. The heat source can either be an external boiler, a domestic water heater, a heat pump or an electric coil built into the unit. An electric coil is usually used only to boost heat pump systems in very cold weather. Most units are equipped with one or two fans, one or more coils for heating or cooling, a condensate pan and drain to remove condensation from the cooling coil, and an air filter (Figure 8).

Residential fan coil units can be purchased as horizontal types designed to be installed in ceilings, vertical units for mechanical room installation or wall-mounted units. Because fan coils are common in commercial applications, commercial mechanical equipment suppliers are often the best source for units with a wide range of features.

### **Fan coil system components**

#### ***Fans***

Fan coil fans are similar to those for furnaces, though they are usually smaller. See the furnace section of this chapter for more details.

#### ***Heating and cooling coils***

The heating coil is typically copper with aluminum fins and is supplied with hot water from an external boiler or domestic water heater. Water is supplied at temperatures ranging from 40°C to 95°C (100°F to 200°F), with 85°C (180°F) being typical.

If cooling is required, a separate evaporator coil supplied by an air conditioning or heat pump unit is the most common arrangement. Coils are available with capacities ranging from 5 kW to 18 kW (18,000 BTU to 60,000 BTU) per hour.

All cooling coils will condense moisture from the airstream on the coil surfaces. This moisture must be collected in a drain pan and disposed of without allowing standing water in the airstream. The pans must be equipped with a drain line which is continuously sloped from the fan coil unit to its outlet. Better units also have insulated drain pans to avoid condensation on the lower surfaces of the unit.

#### ***Filters***

Like furnaces, fan coil units are usually equipped with a basic filter at the return inlet, upstream of the fan. The standard filter, typically supplied with the unit, is a low- to medium-efficiency disposable filter. The filter carrier in the unit should allow for removal and replacement of the filter easily without disconnecting ductwork. For better filtration performance additional filters may be added. See Chapter 6 for more details.

#### ***Controls***

The basic control in a heating-only fan coil system is a single, low-voltage thermostat located centrally in the dwelling. The thermostat operates the pump which circulates hot water through the coil and often steps up the fan speed. This is similar to a furnace system.

Units with water coils should have a low-temperature sensor mounted in the return air inlet and controls to prevent coil freezing by shutting down the supply fan.

#### ***Integration with ventilation systems***

Fan coils can be integrated with ventilation systems in much the same way as furnaces. See the previous section for more details.

Fan coil units provide a great deal of flexibility in design and operation for forced air heating or



cooling. They are well suited to integration with heat recovery ventilators and exhaust-only ventilation systems. If hydronic (hot water) heating is already contemplated, the use of a fan coil to provide heating to spaces that are not heated by local radiators or radiant floors makes them an attractive choice.

#### ***Advantages***

- Little charring of dust.
- Easily integrated with hot water radiant floors and radiators.
- Can provide ventilation.
- Can provide filtration.
- Can provide cooling.
- Can provide central humidification.
- Temperature of supply air is adjustable.
- Will typically be quieter than a furnace.

#### ***Disadvantages***

- Water leaks can cause damage.
- Costly whole system.
- Air movement may cause discomfort because delivery temperature is low.
- Air movement stirs dust.
- Ducts accumulate dust.
- Space required for ducts.

It is relatively inexpensive to oversize a furnace to provide it with quick heat response. Since oversizing a fan coil and boiler system is more expensive, the heat response rate is typically less than with a furnace.

#### **Capital costs and life expectancy**

Fan coil units themselves cost between \$700 and \$1,600, depending on size and options. They should last 15 to 25 years. However, when the cost of the heating or cooling source equipment, pumps, piping and air distribution ductwork is considered, the total system cost is often higher than many other systems. System costs can be reduced by using an integrated heating and domestic hot water boiler, and by placing all mechanical equipment in one central room to reduce piping and ductwork runs. In return for the increased investment, a good fan coil system can provide excellent comfort conditions and ventilation. It should be considered where budget allows.

#### **Operating costs**

Operating costs for the fan coil alone are mainly due to the electricity required to run the fan and the associated pump. This can range from \$35 to \$75 per year, depending on electricity charges. Costs of heating and cooling are widely variable and depend on building design and equipment type.

#### **Maintenance**

Maintenance of a fan coil is minimal. A semi-annual inspection that includes filter replacement, inspection, cleaning and annual lubrication of the motor (if required) are all that is recommended. This is similar to the maintenance required for forced air furnaces. For cooling systems, drain pans should also be inspected and cleaned at least quarterly to ensure proper drainage and to remove biological contaminants.

#### **Applications for the environmentally hypersensitive**

*Fan coil-based heating and cooling systems have the general advantages of forced air systems without some of the disadvantages. Because they recirculate house air, it is possible to introduce high-performance filtration which will control dust. In some cases, gas-removal filters are also*

used to control odours. The major difference between fan coils and conventional furnaces is that the heat exchange surface remains at a relatively low temperature, thereby avoiding many of the dust complaints of conventional furnaces. Furthermore, if the heat source is a natural gas or oil boiler, it may be easily located, remote from the occupied part of the building with no indoor gas connections, oil pipes, vents or chimneys. This reduces exposure to these hazards.

Fan coils are a popular adaptation of forced air systems for the environmentally hypersensitive, particularly in existing homes with forced air ducts in place. The electric booster elements which provide supplementary heat for heat pump systems may be acceptable for occasional use, but are still prone to "frying dust" odours.

## Heat Pumps and Central Air Conditioning Systems

These systems use a fan coil forced air system, described previously, supplied by a heat pump or air conditioner. A heat pump is similar to a refrigeration unit which moves heat from one point to another, using a vapour-compression cycle. In the heating operation, heat is drawn from a low-temperature source, such as the outside air or groundwater, and transferred to the supply air for the home. In cooling operation, heat from the air in the home is moved to the outside air or groundwater.

Heat pumps which provide cooling only are called air conditioners.

Air-source heat pumps extract heat from outdoor air. They are effective in milder weather, but are very inefficient in cold weather and are often equipped with electric heating coils. Water-source or ground-source heat pumps obtain their heat from the soil, well water, a lake or a river. These have the advantage of maintaining their efficiency during very cold weather, but are more expensive to install (figures 11 and 12). Overall, the water- or ground-source heat pump application has the most consistent efficiency and lowest operating costs of residential heating and cooling systems.

Heat pumps and air conditioners use refrigerant liquids which absorb heat as they evaporate. Though the refrigerant is moved by a compressor driven by an electric motor, the energy required to

Figure 11:  
Air Source Heat Pump

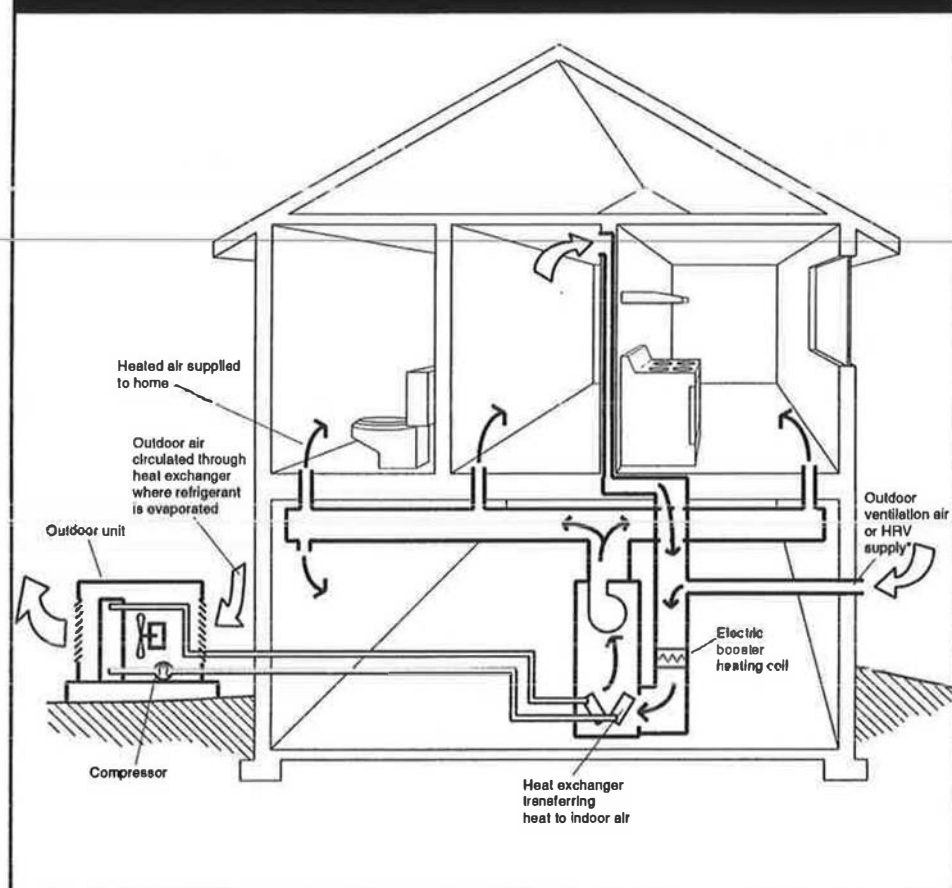
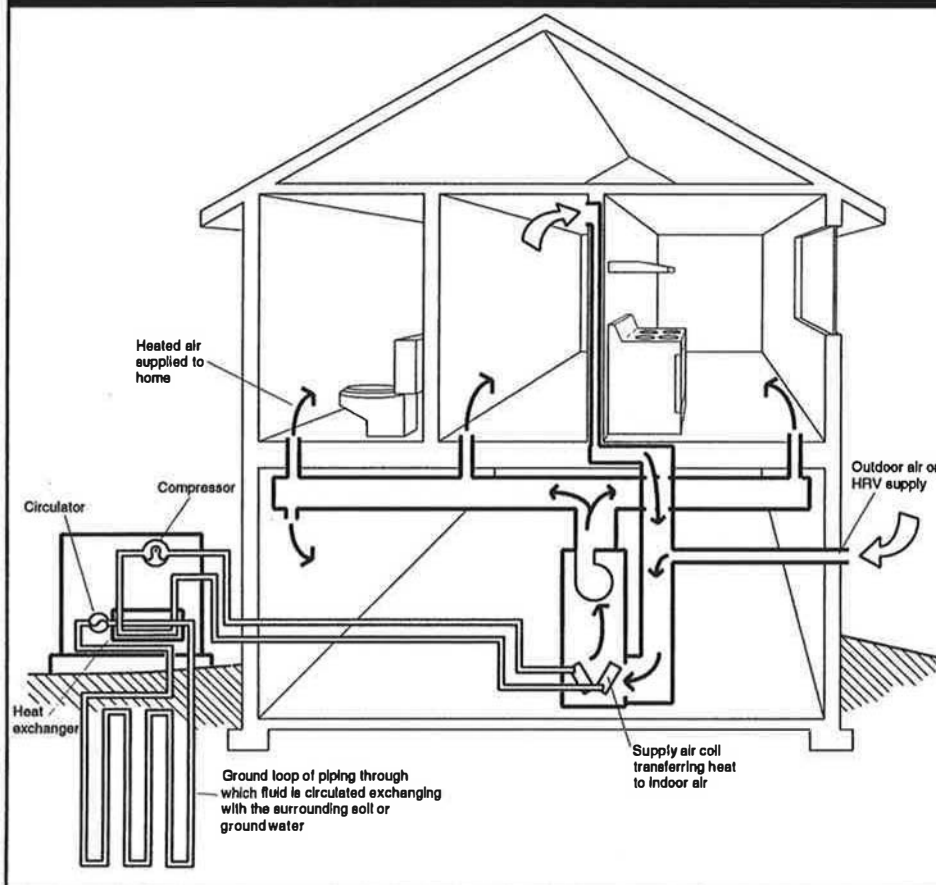

Figure 12:  
Ground Source Heat Pump



and production of HCFCs is to end in 2010 in all countries which participated in the Montréal Protocol of 1987.

Most new heat pumps and air conditioners no longer use the most destructive CFCs, such as R11 and R12. They now use less damaging HCFCs, such as R22. Replacement of older units and avoidance of leaks of R11 and R12 should now be a high priority. Reclamation of CFCs and HCFCs from cooling equipment when servicing is also the law in some provinces, as is the prohibition of refrigerant venting to the atmosphere, both during servicing or at the end of the

operate the motor is less than the amount of heat provided by the heat pump. This is the main advantage of heat pumps and air conditioners. The owner pays only for moving the heat, not for the heat itself. The heat moved is usually two to three times the energy required for operation of the compressor motor. The ratio of the energy required to operate a heat pump motor to the amount of heat moved by the heat pump is referred to as the coefficient of performance (COP). Air-source heat pumps have COPs in the range of two to three and ground-source heat pumps have COPs of three and above.

Both chlorofluorocarbons (CFCs) and hydrochlorofluorocarbons (HCFCs) are used as refrigerants in heat pumps and air conditioners. These have been found to damage the earth's stratospheric ozone layer and are potent greenhouse gases. Production of new CFCs

equipment's life. Air conditioners and heat pumps should only be serviced by qualified service personnel that have been certified for environmentally safe servicing of this equipment.

### Components

Most air-source units have a packaged outdoor unit containing the compressor, heat exchange coil(s) and a fan. The only connections to the home are an electrical supply and insulated refrigerant lines. Ground-source pumps can be located indoors or outdoors, and may also be sold as a packaged unit, similar to an air-source unit. They have similar connections to the air handler unit, but with the addition of liquid exchange pipes to the ground heat source and a pump instead of the outdoor fan.

Heat pumps use fan coils as a means of exchanging heat to and from the house air. See the fan coil section of this chapter for more details.

### **General pros and cons**

Heat pumps are the most energy-efficient means of heating using electricity. They can use various sources of heat and can also provide cooling and dehumidification.

Because the cooling coil may be below the dewpoint temperature under cooling operation, water may condense from the airstream onto the coil surface. This has the effect of dehumidifying the air supplied to the house. Condensed water must be collected and drained away from the coil without pooling in order to prevent the growth of hazardous bacteria and fungi.

The main disadvantages are the high equipment cost and the potential noise from air-source outdoor units.

### **Advantages**

- Minimal heating of dust.
- Can provide heating and cooling in one unit.
- Fan coil system can provide ventilation and filtration.
- Dehumidifies while cooling.
- Can use air or groundwater as a heat source.
- Energy-efficient use of electricity.

### **Disadvantages**

- High capital costs for whole system for heating and cooling.
- Poorly designed air movement may cause discomfort when heating because delivery temperature can be low.
- Air movement stirs dust.

- Ducts accumulate dust.
- Space required for ducts.
- Outdoor air-source units may be noisy.
- Higher maintenance costs, more sophisticated service people required.

### **Capital costs and life expectancy**

Heat pump units or central air conditioners themselves cost between about \$1,500 and \$4,000, depending on size, configuration and options. They last about 10 to 15 years. Groundwater-source heat pumps also require the water collection or underground heat rejection and collection circuits which can range from about \$2,500 to \$10,000. When coupled with the cost of pumps, piping and air distribution ductwork, this places the total system costs as the highest of residential systems. Air-source heat pumps and air conditioners are typically cheaper in capital cost, but more expensive to run than ground-source heat pumps. In return for the increased investment, a good heat pump system can provide excellent air quality, comfort and ventilation. Heat pumps are often an appropriate choice where budget allows.

### **Operating costs**

Electricity is the main operating cost to run the compressor, fans and, possibly, a circulating pump. For air-source units in Canada, the cost of electric booster coil operation can also be significant. Total operation costs depend on climate and system design, but are generally less than half of an equivalent amount of electric heat.

### **Maintenance**

Regular maintenance of heat pumps and air conditioners is minimal. A semi-annual inspection that includes filter replacement, inspection and cleaning of the coils and drain pan, and annual lubrication of the motors (if required), is recommended. Compressors are typically sealed units requiring no maintenance. This is similar

to the maintenance required for forced air furnaces. However, service requires more sophisticated service people.

### **Applications for the environmentally hypersensitive**

*A heat pump as a source of heating and cooling has the inherent advantage of electric systems in avoiding the use of gas and oil fuels in and around the home. The heat exchange method is low-temperature and has the merits of providing for filtration of recirculated air. The main disadvantages for the environmentally hypersensitive are the slight risk of refrigerant leaks and the noise generated by an outdoor unit's fan while operating. Though the risk of leaks is very small, and the outdoor unit can be installed well away from the home to reduce noise complaints, these are still concerns for some.*

*Since heat pumps can provide cooling to the residence, they allow the possibility of reducing the outdoor air-exchange rate in the summer. This can be very important to those with a pollen allergy or when outdoor air quality is poor in the summer. Dehumidification to control mildew growth is another important advantage of summer cooling in some regions.*

*Where a special room or sanctuary is being provided for the hypersensitive, it is often isolated from the rest of the home. In this case, a small split-system air conditioner or heat pump may be useful. These units have a wall-mounted fan coil and a remote outdoor unit which may be located several metres away from the building, making it far quieter than a window air conditioner. The fan coil can provide some filtration and ventilation in a few models. See the portable equipment reports in this chapter for more details.*

### **Convection Heating Systems**

Convection heating systems consist of long, narrow heaters usually placed beneath windows (baseboard units) or wall-mounted cabinet units. They heat the space by warming air adjacent to the heating element which then rises out of the

heater and up the wall by buoyancy. Cooler air enters the heater from below to be warmed. The heaters may use electricity or may be supplied with hot water, circulated from an electric or fuel-fired central boiler (hydronic convectors). Some convection systems are recessed into floors, walls or cabinets and operate with the assistance of a small fan (Figure 13).

Similar to furnaces, the primary air quality concern with convection heat is the temperature of the heat exchanger. Conventional electric heaters can produce hot dust odours due to their high surface temperature, but low-temperature units, called hydronic convectors, have the same advantage as hot water fan coils. These are either individual, liquid-filled electric units, or units served by a boiler. Hydronic heaters operate best at 85°C to 95°C (180°F to 200°F).

There are two types of low-temperature electric convectors: the low-watt density and liquid-filled types. Low-watt density units are simply heaters with less heat capacity per unit of length, so the surface temperature remains lower. They require more wall space, but can be useful where electric heat is to be used and the budget is limited. The liquid-filled units have a sealed loop, containing an electric heat element and a heat transfer liquid. Their performance is very similar to hydronic heat, but they require no boiler or plumbing. They are, however, much more costly to buy than conventional, electric baseboards and have only slight operating cost savings if any (Figure 14).

Though convection heating has merit, it cannot provide ventilation or dehumidification. In order to provide air filtration, humidification, dehumidification or ventilation, a separate air distribution system must be installed.

### **Controls**

Convectors may be controlled individually, in groups or centrally. While electric units are generally controlled by wall or built-in thermostats, hot water systems are controlled by electrical valves supplying hot water in response to wall thermostats. A room-by-room heat loss

analysis is required to size individual room convectors correctly.

**General pros and cons**

Conventional electric baseboard heaters allow for easy temperature control and zoning, and are low in capital cost. However, the cost of separate air filtration and ventilation must also be considered.

**Low-temperature electric or hydronic baseboards**

*Advantages*

- Minimal charring of dust.
- Zone heating control.
- Little circulation of dust.
- Hydronic heat can be done with any type of fuel.
- Hydronic heat can be combined with hot water radiant floor systems.

**Figure 14:  
Liquid Filled Electric Heaters**

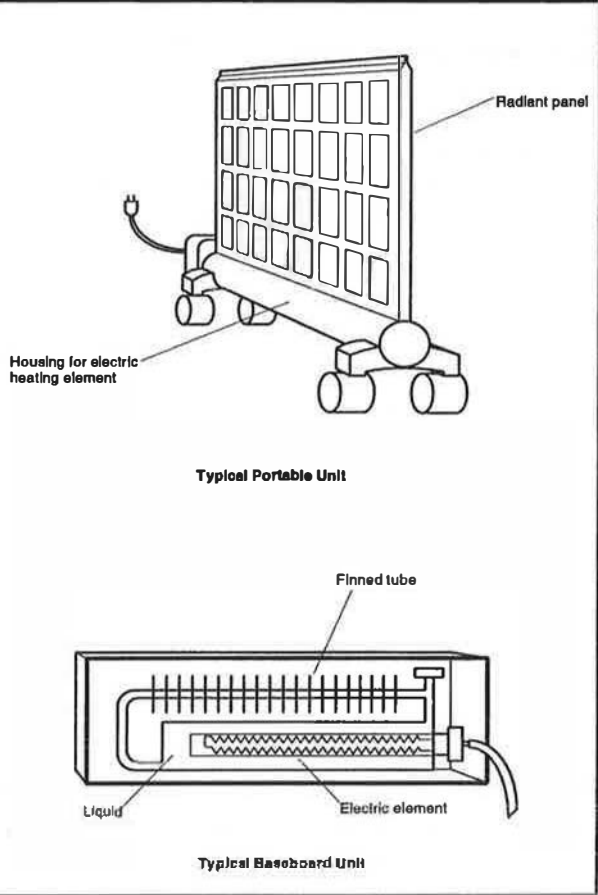

**Figure 13:  
Baseboard Convection Heater**

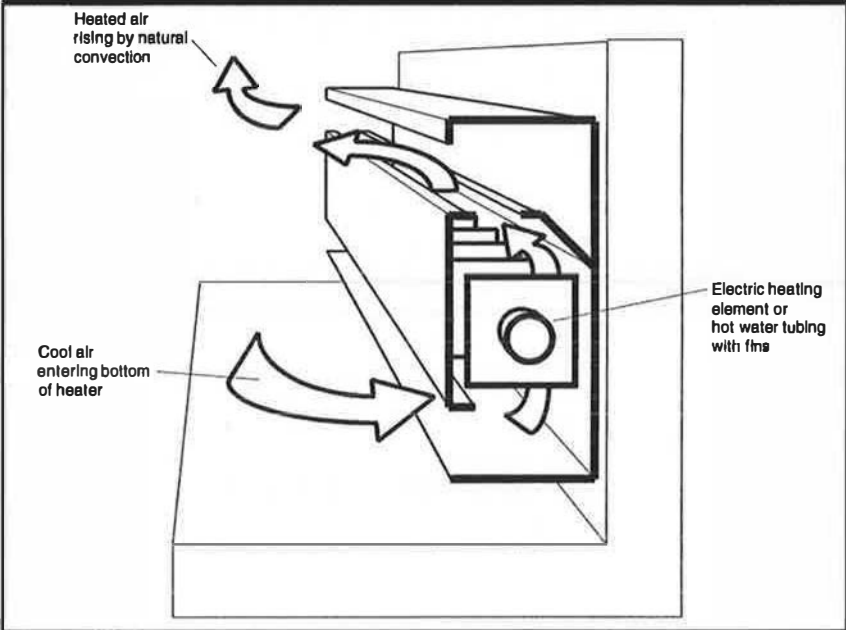

*Disadvantages*

- Higher capital cost than conventional electric baseboards.
- Furniture placement is affected by baseboard location.
- No filtration of room air.
- Higher cost for installing distributed mechanical ventilation system.
- No humidification or dehumidification capability.

- May be difficult to clean.
- Electric heat is expensive to operate.

### **Applications for the environmentally hypersensitive**

*Low-temperature electric or hydronic baseboards can be appropriate for the hypersensitive when combined with a ventilation system and, possibly, an air filtration system. However, there are a few disadvantages. Dust collects on the fins of the heating units and is very difficult to remove. Most fins are also made from aluminum, a reactive metal which some very sensitive people find has a detectable odour when hot. A few manufacturers make special units with stainless steel parts, but these are very expensive.*

*One important factor to recognize with zone-controlled heating systems is that lowering temperature excessively in unused rooms (such as spare bedrooms) in winter can lead to elevated relative humidity and mold and mildew growth. It is best to always keep the thermostat set at 15°C (62°F) or higher at all times.*

### **Radiant Heating Systems**

Radiant heating systems function by heating people and objects directly, not by heating the air in the room (Figure 15). We all experience radiant heating when we are outside on a cold, sunny day and can feel the warmth of the sun. Conversely, a room with a large, cold window will feel cold even if the room air temperature is comfortable. The human body is very sensitive to radiant energy differences of this type.

To work effectively, radiant home heating requires the heating of large surfaces such as floors, walls and ceilings. Radiant-heated floors have important merits because human comfort is regulated, to a large extent, by the temperature of the feet. Having the feet about 3°C to 8°C (5°F to 15°F) above the temperature of the head will help a person feel comfortable even in moderately low air temperatures. Heated floors and ceilings typically operate at about 22°C to 24°C (72°F to

75°F). A large area, heated to just slightly above skin temperature, will provide uniform comfort with minimal air currents, without effects, such as dust stirring and odours, from heated dust which are associated with high-temperature systems. It should be remembered that radiant-heated ceilings will also heat the floor above, and concrete-slab floors with radiant heating will require perimeter and sub-slab insulation to reduce heat loss to the soil.

### **Types of radiant heating systems**

#### *Electric systems*

One type of electric, radiant-heating system consists of cable that is suitable for casting into concrete slabs. In wood frame construction, this cable can be enclosed in a thin concrete or gypsum-concrete layer that is poured over the sub-floor. This cable may also be fastened onto drywall backing and covered with several layers of plaster.

More recently, electric radiant systems have become available which consist of a carbon-film heating element sandwiched between two layers of heavy, polyethylene film. This type of electric heating element can then be placed under a concrete slab or gypsum-concrete layer for a floor, or it can be stapled to wall and ceiling framing before application of the drywall. Pre-assembled, electric, radiant-heating systems are also available as 25 mm (1 inch) thickness, gypsum drywall panels. The electric cables are already cast inside the gypsum panels and are connected after installation. Canadian Standards Association (CSA) approval of these units should be confirmed, as some units have caused home fires.

Electric, radiant-heating systems can produce odours from the heated materials including emissions from paints and other finishes applied to the surfaces. Another concern is possible health effects from low-frequency electromagnetic fields produced by these systems. It should be noted, however, that any health risk has not been precisely established. No maximum electrical

Figure 15:  
Radiant Heating

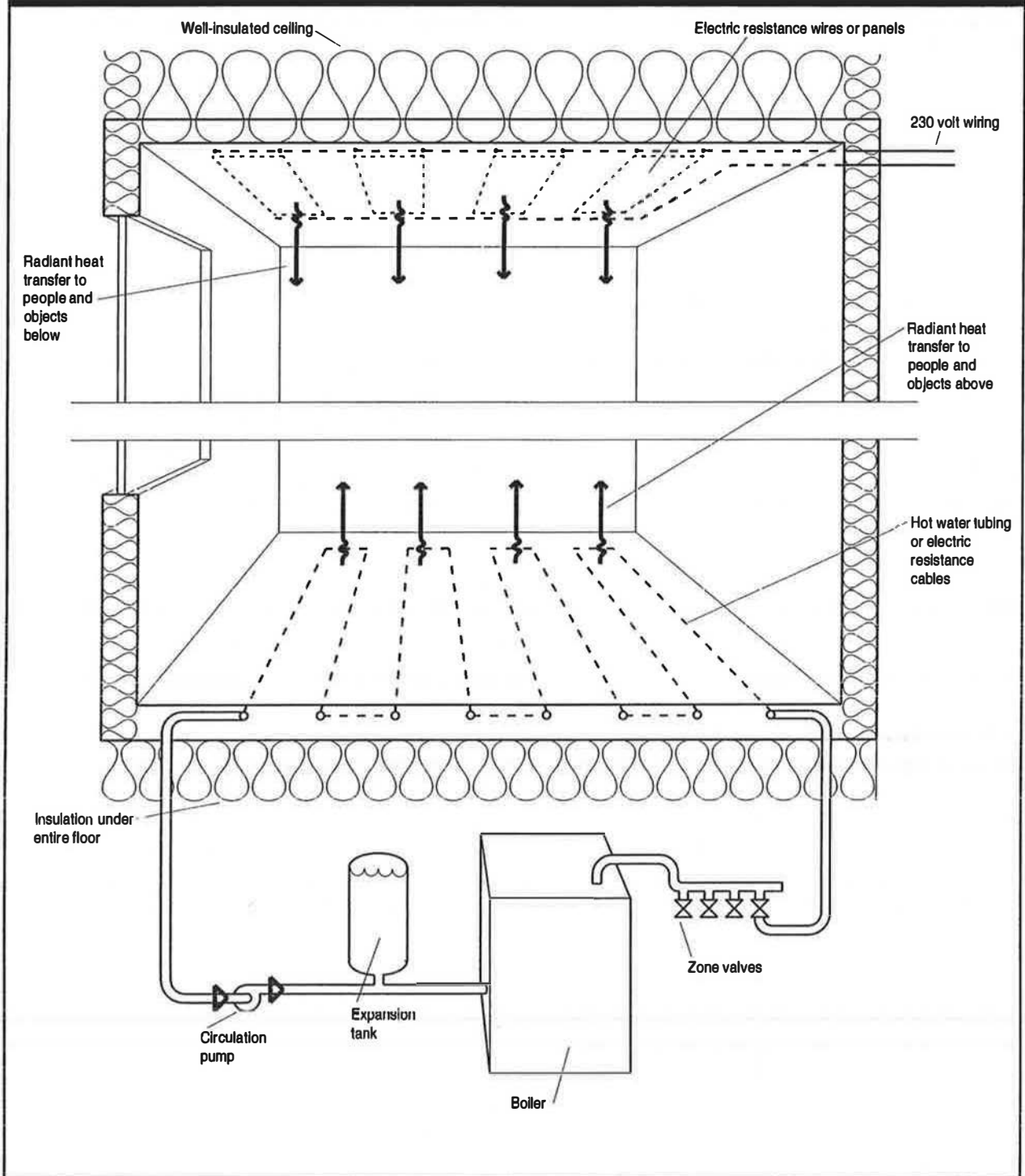



field exposure limits exist for residential situations and there are many other sources of stronger fields in homes. However, the fact that fields from electric, radiant heating are widely distributed throughout the house and cannot be avoided, is enough reason for some to take a cautious approach and avoid these systems. Furthermore, using resistance electrical heating is a wasteful use of electricity.

It is possible to design electric radiant panels to reduce the field emissions, and this has been done by some manufacturers. These units may be acceptable choices where electricity will be used for heating. Manufacturers and dealers should be asked to provide evidence that their units have been designed to minimize electromagnetic field emissions.

### ***Hot water systems***

Traditionally, hot water (or hydronic) radiant-heating systems consisted of copper piping, cast into concrete floor slabs. Due to the corrosive effect of concrete and the heated water on copper, corrosion leaks in the piping became a problem. Modern systems use plastic piping or metal and plastic composites which can be cast into a concrete slab, encased in a lightweight concrete or gypsum-concrete topping on wood sub-floors, or enclosed in the floor joist cavity, below wood framed floors.

Similar to convection heating, radiant heating cannot provide ventilation or dehumidification. In order to provide air filtration, humidification, dehumidification or ventilation, a separate air distribution system must be installed.

### **Controls**

Similar to convection systems, radiant heating systems are generally zoned on a room-by-room basis, or two or three rooms together. It is also possible to zone specific areas within a larger room. Electric radiant systems are switched by wall-mounted thermostats in the same way as electric baseboard heaters. Hot water systems are controlled by an electric zone-control valve

connected to a room thermostat similar to hydronic systems. An indoor-outdoor thermostat is often added to hot water systems for additional control. The thermostat regulates the temperature of the water in the loop so it is warmer on colder days and not as warm on mild days. Night setback thermostats are not appropriate for high-mass (embedded pipe or panel) systems, due to time lags.

A well-designed radiant system can provide very close control of comfort due to the zoning ability and flexibility of distribution. More heat should be supplied in front of a large glass area, for example, rather than along a wall that is well insulated.

### **General pros and cons**

Radiant heating systems can provide very good comfort and do not stir or burn dust. They allow for cooler air temperatures which are often preferred for health reasons. They can also be invisible in the room and not interfere with furniture placement. However, radiant-floor heating systems generally work best with concrete, stone or ceramic floor finishes. Laying carpet and underpad on top of the radiant floor heating is not recommended because these materials would be baked by the heat, resulting in significant and serious emissions into the air. Hardwood is sometimes used, but there can be problems with shrinkage and warping of the material and offgassing of adhesives.

Hot water radiant systems can take advantage of low-temperature energy sources such as those that might be available from a solar collector or waste energy recovery system. Other hot water heating systems, such as forced air and particularly hydronic baseboard convectors, require a higher temperature fluid in order to work effectively.

### ***Advantages***

- Minimal stirring or burning of dust.
- Excellent comfort.

- Lower air temperatures.
- Accurate local control.
- No obstruction to furniture placement.
- Can be integrated with the domestic hot water system.
- Can use low-temperature energy sources.
- Can take advantage of thermal mass of materials for heat stability.

#### **Disadvantages**

- Typical systems are more expensive to install than other heating systems.
- Slow response time.
- Cannot provide air filtration, cooling or ventilation.
- Additional cost for distributed ventilation system.
- Cannot control humidity.
- Incompatible with carpeted floors and some hardwoods.

#### **Capital costs**

A very simple system consisting of polybutylene piping running in the floor joist cavities and supplied by an efficient water heater can be competitive with forced air heating for the same house. However, more common systems using multi-zoned piping loops cast into concrete-topping layers can be very costly—up to three times the cost of a forced air system. For fuel-fired systems, the cost of a boiler is usually more than for a basic warm air furnace of equivalent output and efficiency. It can, however, also replace the domestic water heater.

#### **Operating costs**

In general, operating a radiant heating system can cost slightly more than baseboard heaters. Radiant heating systems are often selected because they provide a high level of comfort and because of the freedom they allow in furniture placement.

#### **Applications for the environmentally hypersensitive**

*Radiant heating systems have the lowest heat exchange temperatures of all systems and can provide the best comfort conditions because heat is widely distributed. Air temperature can be kept lower than with other systems contributing to a feeling of freshness. Radiant systems do not collect dust or require cleaning like other heating systems. However, radiant systems do not provide any ventilation or air filtration. This must be provided by systems independent of the heating system.*

*Radiant floors are often a preferred heating system when concrete floor construction is used. In most cases, only concrete, ceramic or stone finishes are used to reduce the risk of offgassing from heated finishes such as carpets, paints, woods and adhesives. Though walls, ceilings and wood framed floors can also be heated by radiant systems, there are similar air quality concerns which may make it inadvisable for the environmentally hypersensitive unless very rigorous material selection is done. The safest approach is to heat ceramic tile only.*

*Other significant concerns for the environmentally hypersensitive are the heat source, the type of distribution tubing for hot water radiant systems and the type of concrete or gypsum used to cover the tubing. Generally, only electric, sealed combustion or fully isolated boilers are recommended. For water distribution, more chemically stable plastic tubing such as polybutylene and cross-linked polyethylene (a heat-resistant form of polyethylene) are usually acceptable. Plastics such as neoprene (polychloroprene rubber) and ethylene propylene diene monomer (EPDM) should be avoided*

because they can offgas when heated. The lightweight concrete cover for the tubing should, ideally, be plain concrete with a lightweight aggregate and no chemical additives. Gypsum concrete (or self-levelling compound) can be a problem due to the additives necessary to make it fluid enough to flow and level itself. It should generally be avoided by the hypersensitive.

Like other zoned heating systems, there is a risk of moisture damage to unused rooms if heat is shut off in winter. See the convection heating section of this chapter for more details.

### Passive Solar Heating Systems

Passive solar heating in its simplest form consists of placing south-facing windows in a home and allowing sunlight to enter so it directly heats the home or is absorbed by massive materials which will release the heat later. These systems rely on elements of the building to accept or reject sunlight, not on mechanical equipment. Any home with southward-facing windows will benefit from passive solar energy if there are not too many obstructions to sunlight entry. In a typical Canadian home, this will usually account for about a 10 per cent contribution to the home's annual space heating requirements. It can, however, contribute as much as 30 per cent for an energy-efficient new home by appropriate window size and placement. Higher solar contributions can be gained by using super energy-efficient windows and carefully placing massive materials for storage (Figure 16).

### General pros and cons

Design of a passive solar home is more critical than other homes if high glare conditions and overheating are to be avoided. All south-facing windows must also have adequate shading to reduce entry of the summer sun and consequent overheating.

### Advantages

- Utilize a free and environmentally sound energy source.
- Require no fuels or mechanical equipment.
- Provide a desirable feature (sunlight) while contributing to space heating.

Figure 16:  
Direct Gain Passive Solar Heating

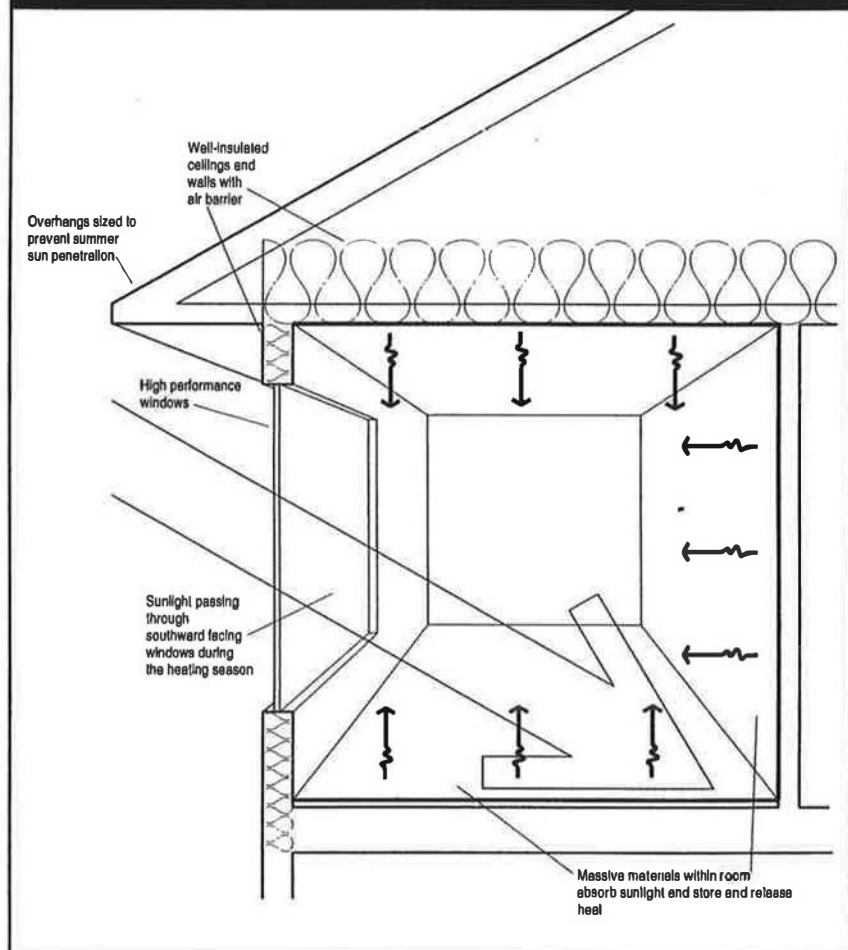

- Can be used to enhance daylighting and reduce electric lighting.
- Often little or no additional cost over typical construction, when designed from concept.

#### **Disadvantages**

- Require a site with direct solar exposure of at least four to six hours per day in late fall, winter and early spring.
- Require more care in design to ensure no glare or overheating.
- May require high capital investment in added mass and super energy-efficient windows to achieve more than the 30 per cent space heating contribution.
- Still require a heating and ventilation system.

#### **Applications for the environmentally hypersensitive**

*Passive solar heating has substantial merits for the environmentally hypersensitive because fossil fuels can be avoided in the home. Homes with substantial south-glazing or solariums also tend to be bright and feel spacious without added electric lighting requirements. These qualities are often noted as very important to hypersensitive individuals, particularly in climates where they may stay indoors for several months of the year.*

*However, there are two concerns about passive solar heating in homes for environmentally hypersensitive individuals. The first is that massive materials which may be used as heat storage in walls and floors become quite warm during sunny conditions, so the use of paints, adhesives, sealants, textiles, paper coverings and other materials which offgas when warm, must be very restricted. The second concern is that houses with substantial passive solar heating ability will tend to become very warm on their south exposures during sunny periods and it may be necessary to distribute heat to other, cooler parts of the house, or vent it. Distributing heat*

*is often done by mixing warm air with cooler air through an air distribution system, using a continuously operating fan. The disadvantage for the environmentally hypersensitive is that odours generated in one part of the house will be distributed throughout, making zoning very difficult. This is a problem where a particular area of the house is to be reserved as a sanctuary for the hypersensitive. If super energy-efficient windows with low-emissivity (low-E) coatings are installed, the quality of the light transmitted by the glazing should be addressed (refer to the CMHC publication, *Building Materials for the Environmentally Hypersensitive*). High insulating properties are a result of the thermal properties of the frame, the types of spacers used and the type of glazing. Low-emissivity (low-E) windows have coatings which reduce the infrared radiation or heat lost from the house, resulting in energy savings, but also altering the transmitted light.*

#### **Portable Heating and Air Conditioning Equipment**

##### **Portable heating equipment**

Portable electric convection heaters are a popular solution for individual room heating, particularly for renters and those on a limited budget who find the existing heating system in their home unacceptable. In homes of the environmentally hypersensitive, it is common to find a bedroom which has been isolated from the forced air heating and a portable electric heater substituted. Generally, the same considerations apply to portable heaters as to permanent convection heaters. For more information, see the convection heating section of this chapter.

Most conventional portable electric baseboard units have high-temperature surfaces which produce odours from “fried” dust. They also are difficult to clean due to the complex heat exchange fins. A few manufacturers make low-temperature, portable units in either a baseboard or vertical radiator style. These are liquid-filled units which have the advantages of lower surface temperature and better comfort. These are the preferred portable units for the environmentally

hypersensitive for adapting a single room (Figure 1.10). However, portable heaters, air conditioners or air filtration units can only be expected to function when used in an enclosed room of a modest size. These units are not capable of serving whole houses or large open areas.

### **Fan-operated portable heaters**

Most portable heaters with fans use a high-temperature electric heating element. These introduce dust odour problems. Furthermore, they often have low-quality fans which are noisy, ineffective and produce odours from wiring insulation and oily residues. This is particularly true of very compact units. There are a few large portable units made which are better quality and have lower temperature heat exchange elements. These may be acceptable to some environmentally hypersensitive people. Electric heaters with ceramic elements may also be more acceptable than heaters with metal elements. Ceramics have lower surface temperatures and are less reactive to air contaminants than metal elements.

Painted surfaces and oily residues on new heaters can also cause irritation to the hypersensitive. These produce odours when heated. A few specialized units are available with all stainless steel construction, plated metal parts or metallic paints which eliminate or reduce this problem.

**Caution:** All portable electric heaters introduce fire risks from overheated cords and overloaded electrical circuits. Manufacturers' instructions should be followed carefully. No extension cords or oversize fuses should be used and heaters must be equipped with safety controls to shut them off if overheated or tipped over.

### ***Portable kerosene, naphtha or propane heaters***

Any fuel-burning heater which does not have an effective chimney to exhaust combustion gases outside is a serious health hazard to everyone. Kerosene heaters, camping heaters and fuel-burning construction heaters are not an option for the environmentally hypersensitive.

## **Air conditioning equipment**

### ***Compact air conditioners***

Window air conditioners are noisy and problematic, but are sometimes an important means of providing comfort in existing homes in the hottest and most humid season. They are also useful for allergic persons during pollen season because they allow cooling without introducing large amounts of pollen-laden outdoor air. They also can provide some basic air filtration (Figure 17).

A typical unit fits into a window opening or is placed in a dedicated opening in an outside wall. It contains a small compressor and fan with two heat exchange coils. The evaporator surface tends to become quite wet when operating because warm room air loses moisture as it condenses on the cool surface. This moisture is collected in a drip pan and carried outside by a small tube which must be kept clean.

Some units have controls to select the amount of outdoor air mixed with recirculated air and basic filters. In some cases, filters can be upgraded to a medium-efficiency type which will remove some pollens, dusts and soot from outdoors. The manufacturer should be consulted about filter options.

The main concern with these units, aside from the noise, is the difficulty in keeping them clean and preventing the growth of microbes in the condensate pan and drainage system. When dust collects on the evaporator and pan, it may clog up the drain tube creating conditions which will grow fungus or bacteria. Some microbes will produce disagreeable odours and stains while others are a health hazard. If window air conditioners are necessary, it is important that they are cleaned and the condensate collection system sterilized regularly.

A split-system air conditioner is a wall-mounted unit containing only the evaporator, a fan and filters. The noisy compressor is mounted separately outdoors. These units often have

better fans and filters than window air conditioners (Figure 17).

Portable air conditioners mounted in cabinets on wheels are also available which use a water-cooling feature to boost efficiency. One model

contains a compressor and evaporator, and has a water-cooled condenser fed from a small water tank. It requires a 10 cm (4 in.) diameter hole in the wall to connect an exhaust duct. These units can also have good quality fans and medium-efficiency air filters (Figure 17).

Figure 17:  
Compact Air Conditioners

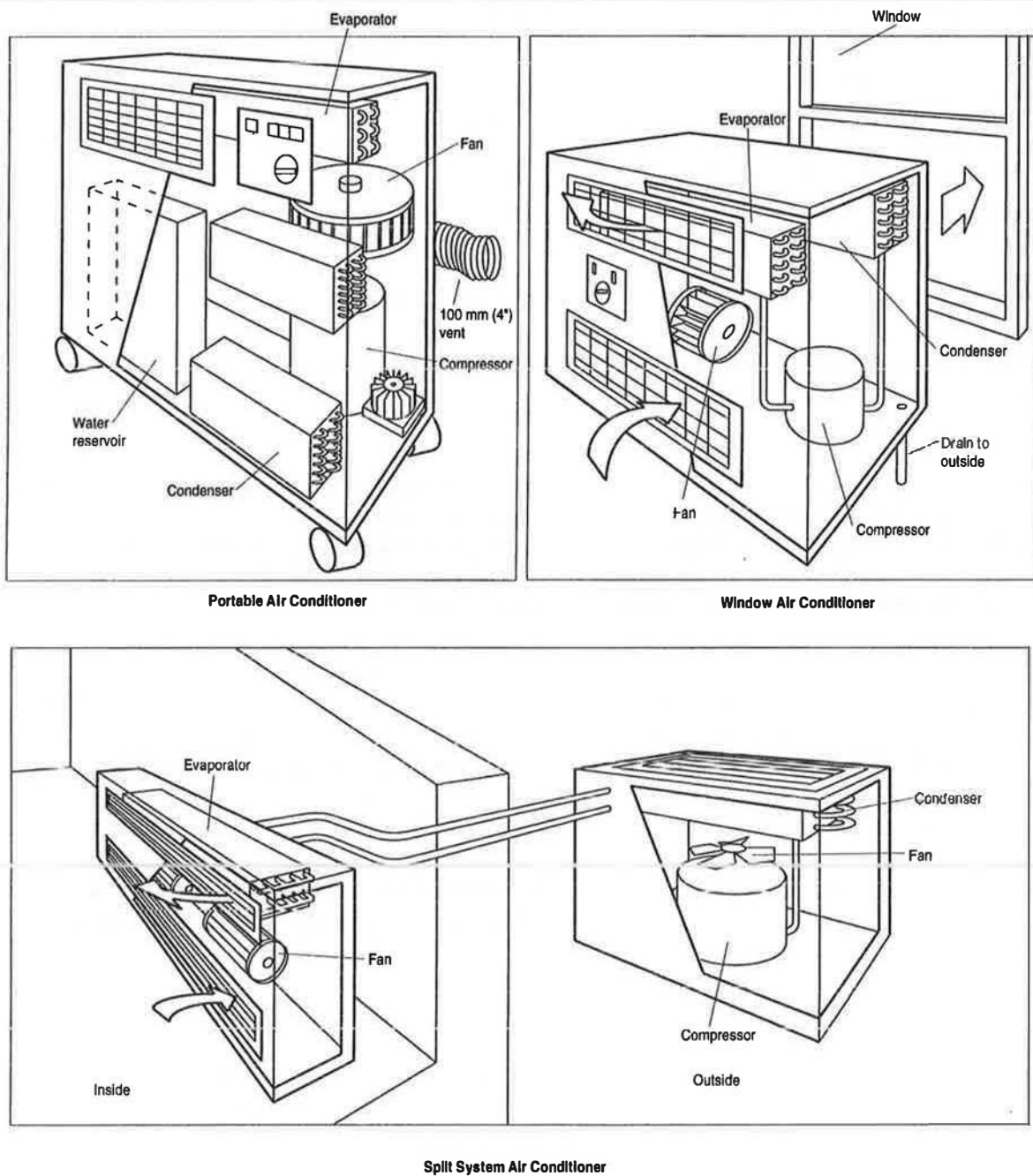

## Boilers

A boiler is a device for heating water, primarily for space heating. It does not usually include a storage tank for domestic hot water supply; however, a single boiler may provide both space heating and domestic hot water. Modern boilers are very compact, quiet and reliable heating options.

Boilers are classified by the fuel type they use and the way in which they operate. The most common boiler types are:

- electric;
- gas or propane; and
- oil.

## Electric boilers

From the perspective of indoor air quality, electric boilers are probably the safest type. There is no fuel that can spill or leak and there are no combustion gases which can escape into the home. An electric boiler can be used in conjunction with a fan coil unit to provide a low-temperature forced air system that eliminates dust burning in the heat element (Figure 18). However, space heating with electricity is expensive and is especially inefficient in regions where electricity is generated thermally (i.e., coal, oil, gas or nuclear). In Ontario, for example, residential space heating with electricity is not permitted except by special agreement.

Figure 18:  
Typical Electric Boiler

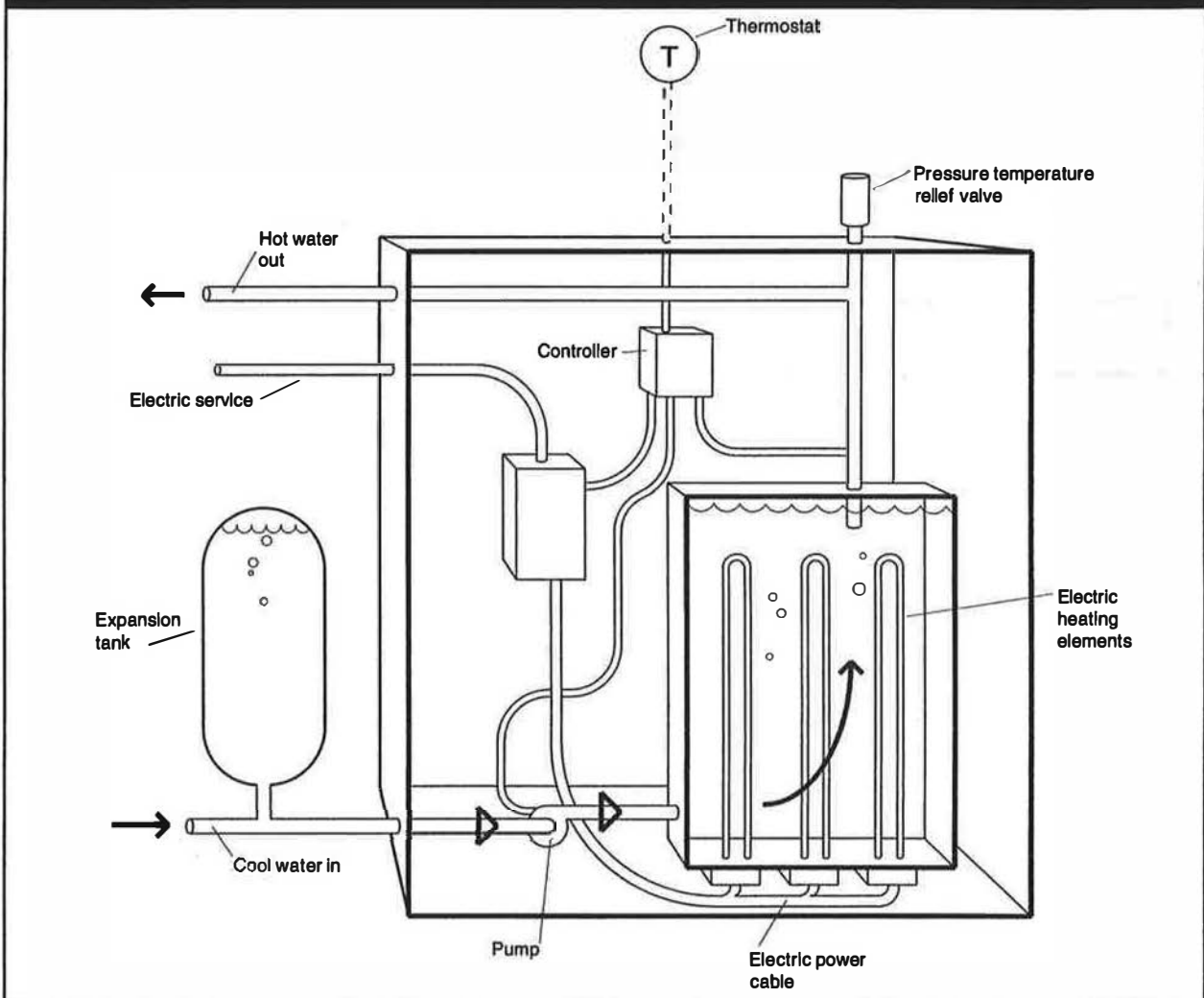

### Gas or propane boilers

The combustion and venting options for gas boilers are similar to gas furnaces. *Though some very sensitive people cannot tolerate any gas appliances in a home, where gas is the preferred fuel for cost reasons, the appliances can often be acceptable if adequately isolated from the home. Hot water (or hydronic) systems provide this flexibility (figures 19, 20, 21).*

### Oil boilers

Oil handling and oil combustion is associated with persistent fuel odours and flue gas pollution. Oil-fired boilers are available in conventional-draft and induced-draft models. Conventional oil-fired boilers located in homes can be modified with a burner delay relay, to reduce flue gas spillage. See Chapter 5.

In locations where there is no alternative fuel, oil is sometimes used by locating the boiler in a remote boiler room with the oil tank and flue located as far from the house as is practical. The hot water delivery pipes to the home must be heavily insulated and the boiler room must be heated in colder regions.

### Maintenance requirements

- Annual burner and flue fan checks.

Figure 19:  
Naturally Aspirated Gas Boiler

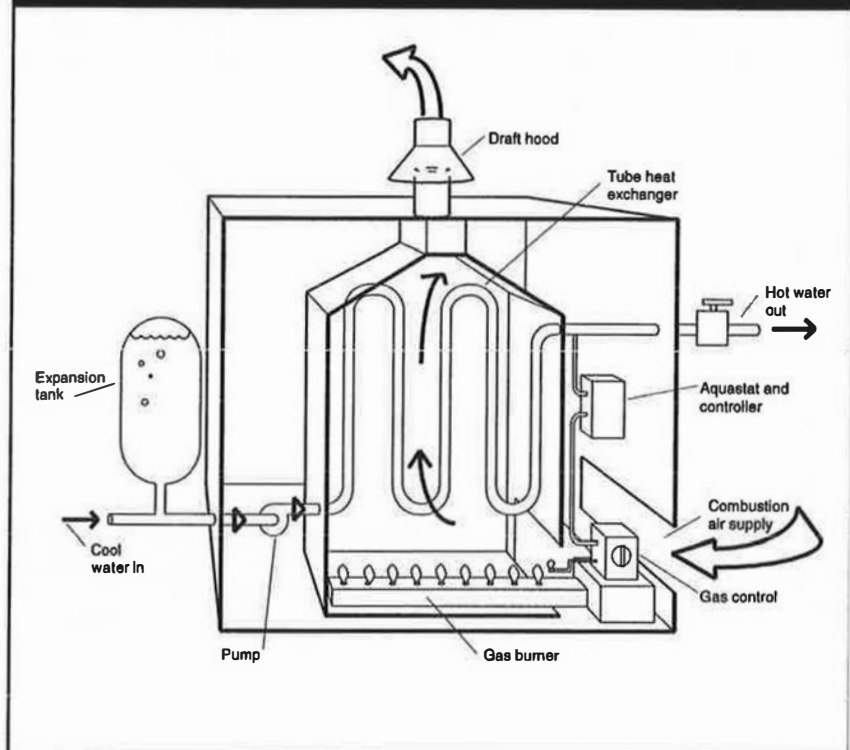

Figure 20:  
Induced Draft Gas Boiler

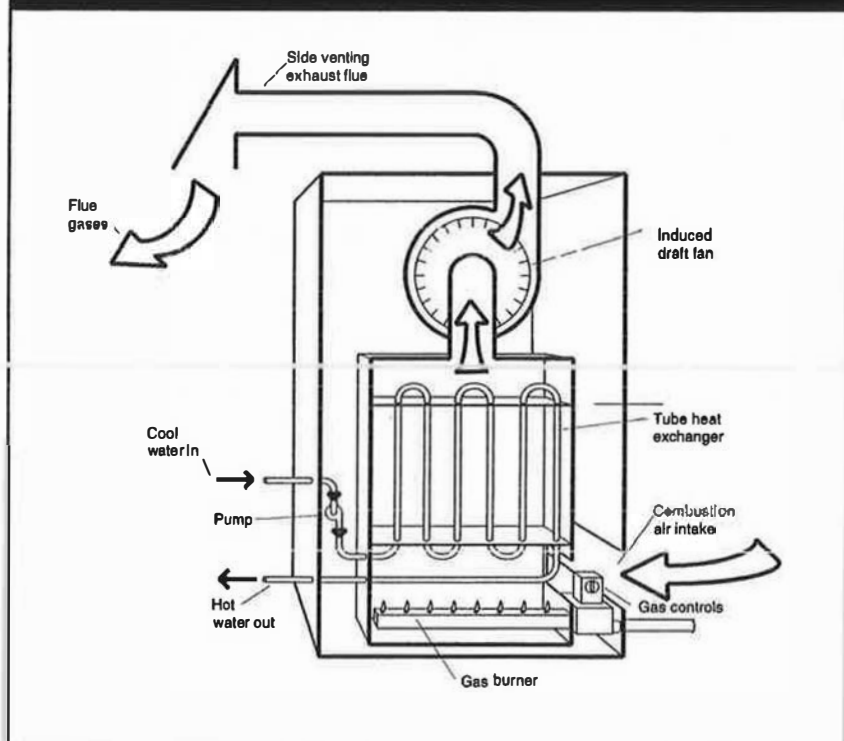
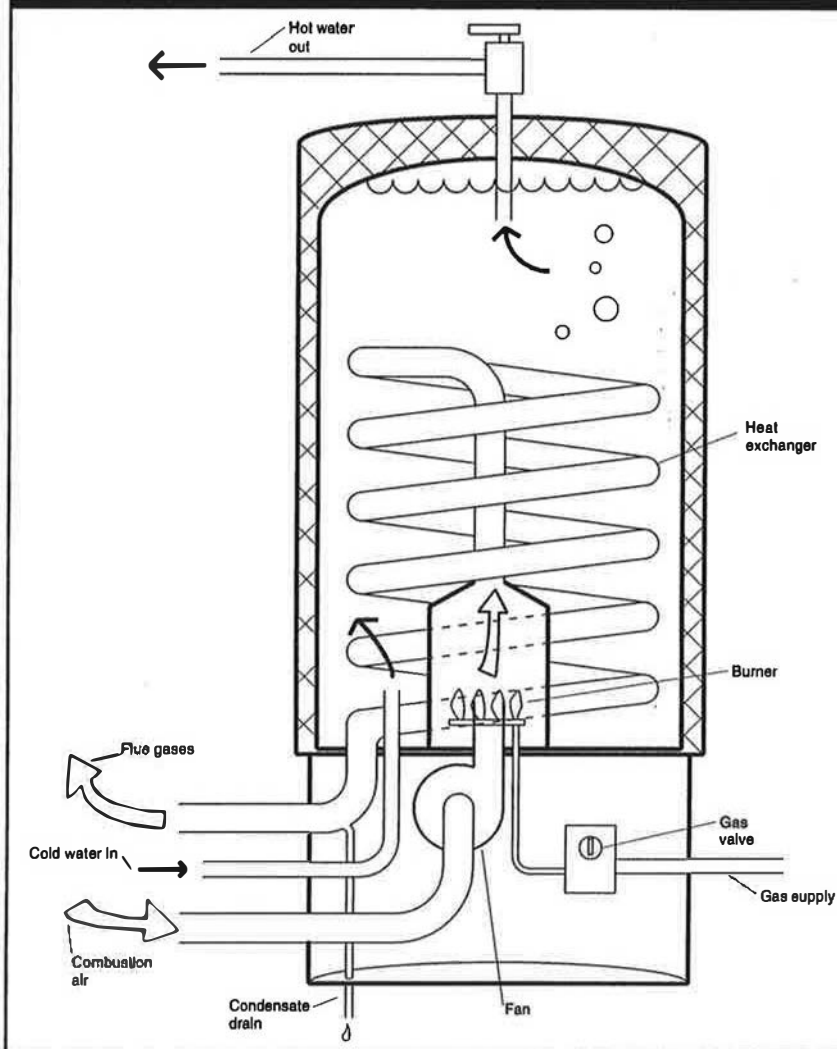



Figure 21:  
Condensing Gas Boiler



**General comments**

All heating boilers may also be used for domestic hot water by providing a second coil or heat exchanger and a storage tank.

**Central Heat Pump/Air Conditioner**

An outside unit with compressor and coil exchanges heat with outdoor air or groundwater. The inside unit is a fan coil. It may require an electric heating coil for the coldest weather. Peak demand could also be met with an oil-fired water heater, with due consideration to avoidance of oil swells and products of combustion.

**Installation considerations and options**

- The outdoor air-source unit may be noisy and should be located in an area remote from quiet areas. Pipes leading to house must be well insulated. An adequate electrical supply is required.

- Semi-annual check of condensate drain on condensing units.
- Oil equipment may require annual tune-up.

**Product sources**

- Heating contractors;
- boiler manufacturers; and
- fuel oil companies.

See also the sections in this chapter on fan coil units, hot water convection heating and hot water radiant heating.

- Can be installed as an “add on” to an existing forced air system.

**Health issues**

**Advantages**

- Low temperature heat exchange reduces burning of dust.
- Has cooling and dehumidifying capabilities for summer weather to reduce risk of mold growth.

**Table 1:  
Boiler summary table**

Boiler Type	IAQ Advantages	IAQ Disadvantage	Efficiency Range	Operating Cost Range	Capital Cost Range
Electric	<ul style="list-style-type: none"> <li>No combustion gases</li> <li>No fuel to spill or leak</li> </ul>		100% <sup>1</sup>	High	Low
Naturally aspirated gas		<ul style="list-style-type: none"> <li>Can spill flue gases (backdraft)</li> <li>Natural gas leakage possible</li> <li>Odours from pilot light</li> </ul>	65%	Medium	Low
Induced draft gas	<ul style="list-style-type: none"> <li>Some resistance to flue gas spillage</li> <li>No pilot odours</li> </ul>	<ul style="list-style-type: none"> <li>Flue gas spillage possible</li> <li>Natural gas leakage possible</li> </ul>	79 to 83%	Low	Medium
Condensing gas	<ul style="list-style-type: none"> <li>Effectively resists flue gas spillage</li> <li>No pilot odours</li> </ul>	<ul style="list-style-type: none"> <li>Natural gas leakage from piping possible</li> <li>Plastic piping may be objectionable to some</li> </ul>	90 to 95%	Very low	High
Conventional oil <sup>2</sup>		<ul style="list-style-type: none"> <li>Easily spills flue gases (backdrafts)</li> <li>Oil leakage from fuel lines possible</li> </ul>	71 to 83%	High	Low
Induced draft oil <sup>2</sup>	<ul style="list-style-type: none"> <li>Limited resistance to flue gas spillage</li> </ul>	<ul style="list-style-type: none"> <li>Oil leakage from fuel lines possible</li> </ul>	85%	Medium	Medium

**Notes:**

- One hundred per cent refers only to the efficiency of converting electricity to heat. If thermally produced, the electricity production and distribution will be only 30 to 40 per cent efficient.
- All oil-burning equipment produces more noxious combustion gases and pollution than gas-burning equipment.

- Allows “windows closed” conditions where outdoor air is unacceptable.
- Occasionally used for new or retrofit forced air systems where electricity is the chosen energy type.

**Disadvantages**

- Costly units to purchase and install.
- Risk of condensate and mold and bacteria growth for cooling models.

**General comment**

Minor risk of coolant leaks.

**Maintenance requirements**

- Annual service, compressor and refrigerant check by qualified service people.
- Cooling fan motor servicing (air-source units).
- If cooling is included, at least quarterly cleaning of condensate drain is essential.

**Operating cost/savings**

Costs 40 to 60 per cent less to operate than direct electric heat.

**Product sources**

- Heating and ventilation contractors; and
- heat pump manufacturers.

See also the information on fan coils in this chapter.

## Domestic Water Heaters

A domestic water heater is a device for heating and storing water for bathing and washing. It does not usually provide space heating although combined systems are sometimes used.

Water heaters are classified by the fuel type they use and the way in which they operate. The most common water heater types are:

- electric;
- natural gas or propane; and
- oil.

### Electric water heaters

From the perspective of indoor air quality, electric hot water tanks are probably the safest type. There is no fuel that can spill or leak and there are no combustion gases. When selecting an electric hot water tank, be sure to choose an energy-efficient one with a Power Smart label or conforming to CSA Std. 191. There are also heat pump-type electric water heaters which often extract heat from house exhaust air. These use much less electricity than conventional electric water heaters (Figure 22).

### Gas or propane water heaters

The combustion and venting of gas or propane water heaters is very similar to furnaces (figures 23 and 24). The one exception is the “sealed combustion” water heater which has a dedicated outside air supply for combustion and a standard vent. It has no draft fan, but is less prone to flue gas spillage than conventional units

Figure 22:  
Electric Hot Water Tank

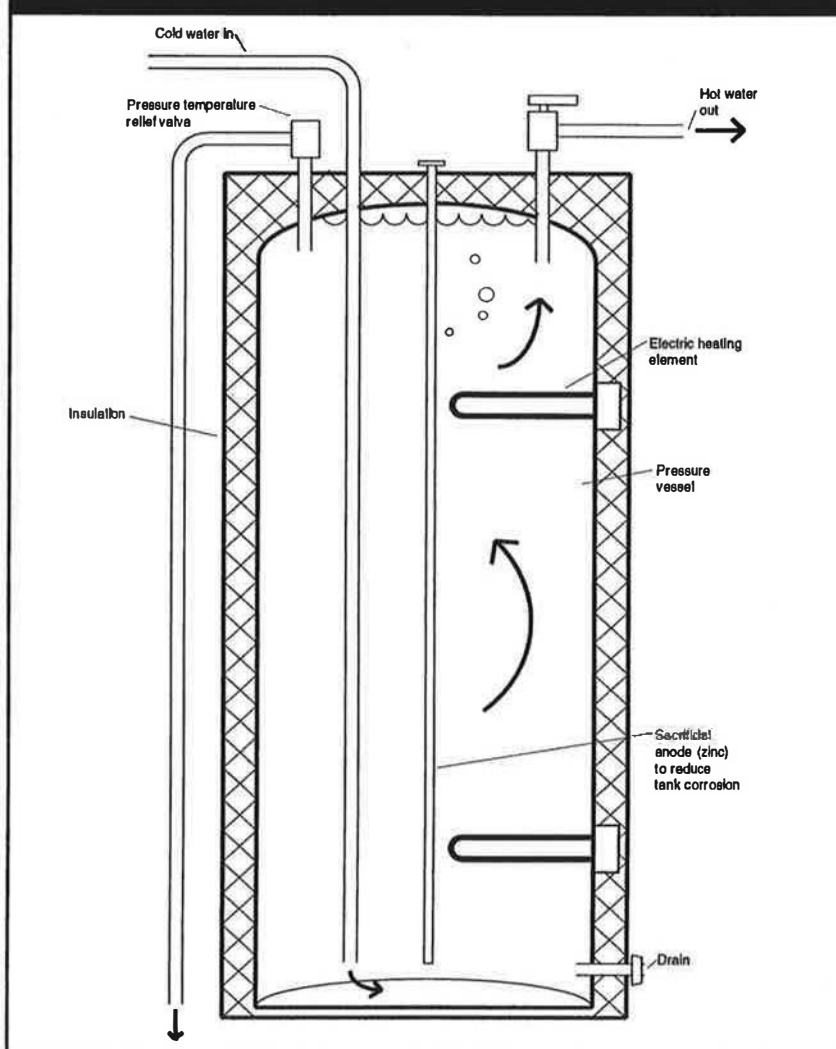

(Figure 25). Some very sensitive people cannot tolerate any gas appliances in a home. However, where gas is the preferred fuel for cost reasons, the appliances can often be acceptable if adequately isolated from the home.

### Oil water heaters

Oil handling and oil combustion are typically associated with persistent odours and flue gas pollution. Oil water heaters are either conventionally vented forced draft or induced draft. Conventional burners can be fitted with a burner delay relay to reduce flue gas spillage. See Chapter 5 for more details. *In locations where there is no alternative fuel, oil is sometimes used*

**Figure 23:**  
**Naturally Aspirated Gas Hot Water Tank**

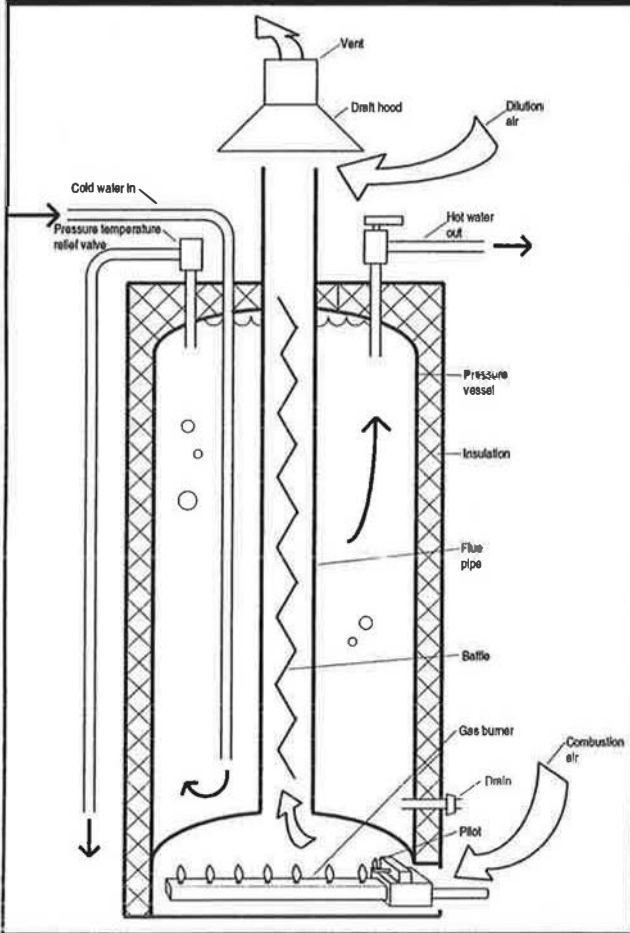

by hypersensitive individuals by locating the device in a remote boiler room with the oil tank and flue located as far from the house as is practical. The hot water delivery pipes to the home must be heavily insulated and the boiler room must be heated in colder regions.

### Electric Radiant Heating

Electric resistance elements mounted behind or imbedded in gypsum panels or concrete floor topping.

#### Other common names

- Ceiling panel heating; and
- electric cable heating (floors or walls).

#### Typical system applications

New construction or retrofit, zoned electric heating systems.

#### Installation considerations and options

- New ceilings or floors must be installed.
- Adequate electrical capacity must be available.
- Ventilation must be provided separately.
- Ensure CSA approval, and carefully install to manufacturers specifications to avoid fire hazards.

#### Health issues

##### Advantages

- Low surface temperature reduces burning dust.
- Good radiant comfort at lower air temperature and with minimum air movement.

##### Disadvantages

- Paints, adhesives, sealers or other finishes applied to heated surfaces must be carefully selected.

#### General comments

Unknown risks from electromagnetic fields suggest caution about these systems. Some systems have been vulnerable to failure, but the CSA has subsequently tightened product installation requirements.

#### Maintenance requirements

None.

Figure 24:  
Induced Draft Water Heater

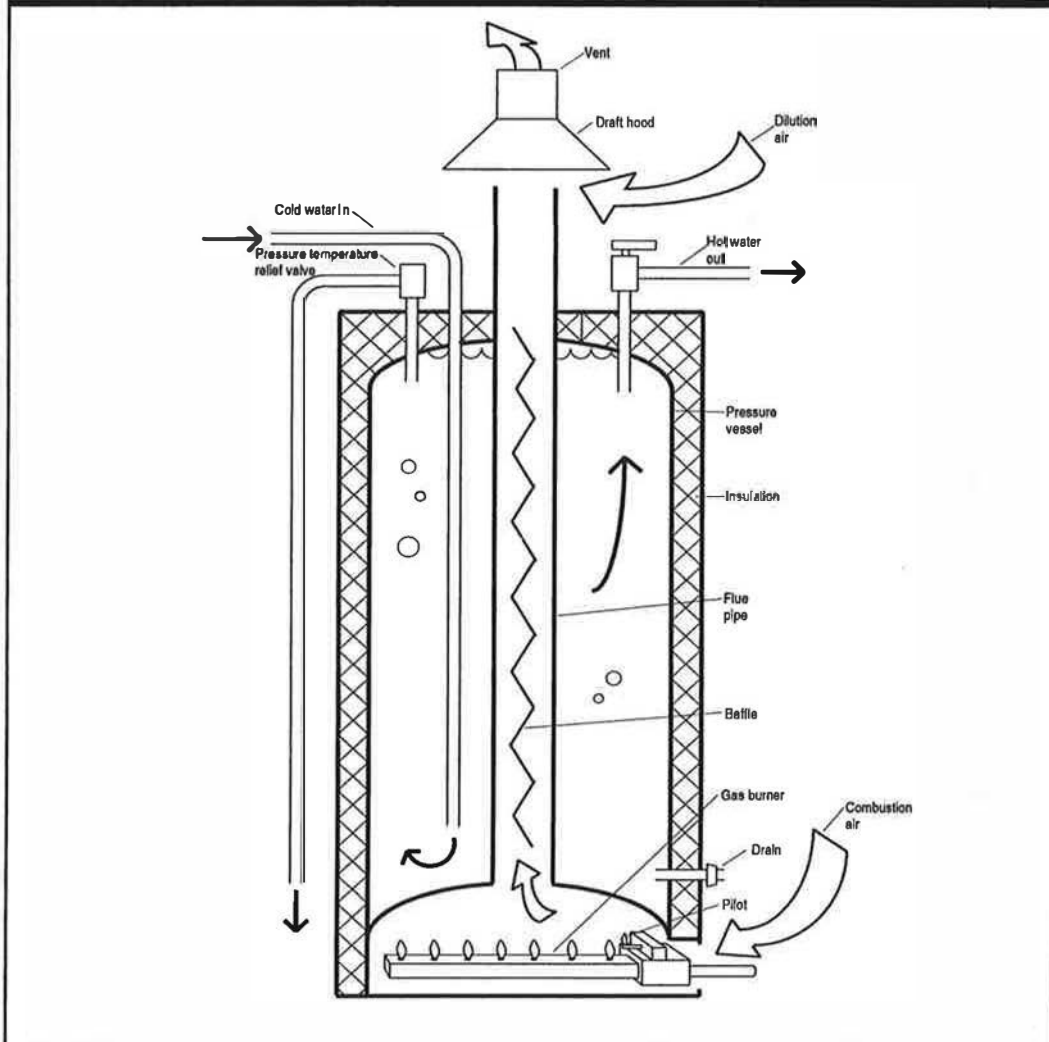

### Operating cost/savings

Typically more costly to operate than other electric systems due to heat loss through insulated surfaces.

### Product sources

- Specialized heating contractors; and
- electrical contractors.

See also the section on hot water radiant heating in this chapter.

### Enclosed Fan Motors

Windings, insulation and bearings which may offgas resins, formaldehyde, hydrocarbons and ozone are not exposed to the air (identifiable by absence of vent slots).

### Other common names

- TEFC (totally enclosed fan cooled) motors;
- TEAO (totally enclosed air over) motors; and
- TENV (totally enclosed non-ventilated) motors.

**Figure 25:**  
**Sealed Combustion Gas Water Heater**

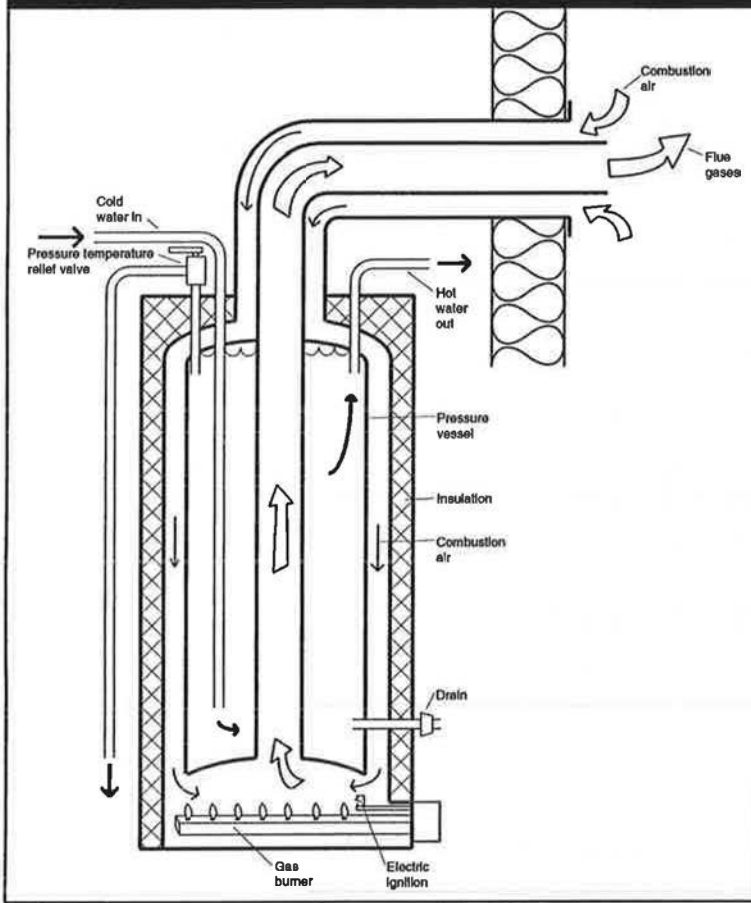

**Disadvantages**

- TEFC motors may not allow speed control.

**General comments**

Some condensing gas furnaces are available with high-efficiency electrically commutated motors (ECM). These are far more efficient multispeed motors than conventional furnace motors and will reduce fan operating costs. Belt-driven furnace blowers can be easily fitted with totally enclosed (TEAO, TENV or TEFC) motors which reduce odours from motor insulation and lubricants. High-efficiency models may not be available.

**Maintenance requirements**

Minimal. Do not require lubrication.

**Operating cost/savings**

Similar operating cost to conventional mid-efficiency motors.

**Typical system applications**

As a replacement motor for belt-driven furnace fans.

**Installation considerations and options**

Limited applications. Usually cannot replace direct drive type furnace fans. Space constraints may also be a problem.

**Health issues**

**Advantages**

- Sealed motors expose less insulation, plastic and oily bearings to the airstream.
- TEFC motor retrofits may be helpful for adapting warm-air systems for the hypersensitive.

**Product sources**

Electrical and machinery suppliers, electrical contractors.

See also furnaces and fan coil units in this chapter.

**Fan Coil Heating/Cooling Unit**

Consists of a fan, heat exchange coil and filter (optional). May contain condensate drain (cooling uses), pumps and insulation.

**Other common names**

- Hot water furnace unit;
- heat pump indoor unit; and
- air conditioner indoor unit.

**Table 2:**  
Water heater summary table

Water Heater Type	IAQ Advantages	IAQ Disadvantage	Efficiency Range	Operating Cost Range	Capital Cost Range
Electric (Power Smart or CSA 191)	<ul style="list-style-type: none"> <li>No combustion gases</li> <li>No fuel to spill or leak</li> </ul>		100% <sup>1</sup>	High	Low
Naturally aspirated gas		Easily spills flue gases (backdraft) <ul style="list-style-type: none"> <li>Odours from pilot light</li> <li>Natural gas leakage possible</li> </ul>	48%	Medium	Low
Mid-efficiency gas	<ul style="list-style-type: none"> <li>Limited resistance to flue gas spillage</li> </ul>	<ul style="list-style-type: none"> <li>Does not eliminate possibility of flue gas spillage</li> <li>Natural gas leakage possible</li> </ul>	58%	Medium	Medium to High
Sealed combustion gas	<ul style="list-style-type: none"> <li>Effectively resists flue gas spillage</li> <li>No pilot odours</li> </ul>	<ul style="list-style-type: none"> <li>Natural gas leakage from piping possible</li> </ul>	58%	Medium	Medium
Condensing gas	<ul style="list-style-type: none"> <li>Effectively resists flue gas spillage</li> <li>No pilot odours</li> </ul>	<ul style="list-style-type: none"> <li>Natural gas leakage from piping possible</li> <li>Plastic piping may be objectionable to some</li> </ul>	90 to 95%	Low	High
Conventional oil <sup>2</sup>		<ul style="list-style-type: none"> <li>Easily spills flue gases (backdraft)</li> <li>Oil leakage from fuel lines possible</li> </ul>		40%	High Low
Induced-draft oil <sup>2</sup>	<ul style="list-style-type: none"> <li>Limited resistance to flue gas spillage</li> </ul>	<ul style="list-style-type: none"> <li>Does not eliminate possibility of flue gas spillage</li> <li>Oil leakage from fuel lines possible</li> </ul>	88%	Medium	Medium
Sealed combustion oil <sup>2</sup>	<ul style="list-style-type: none"> <li>Effectively resists flue gas spillage</li> </ul>	<ul style="list-style-type: none"> <li>Oil leakage from fuel lines possible</li> </ul>	88%	Medium	Medium

**Notes:**

- One hundred per cent refers only to the efficiency of converting electricity to heat. If thermally produced, the electricity production and distribution will be only 30 to 40 per cent efficient.
- All oil-burning equipment produces more noxious combustion gases than gas-burning equipment.

**Typical system applications**

- Heat pump indoor unit for heating and cooling systems.
- Low temperature warm air system with boiler or hot water tank supply.

**Installation considerations and options**

- If used for cooling, this type of system requires ducts sized for heating and cooling. Additional filters may be added.
- Continuous low-speed fan operation is recommended.

- May be retrofitted to replace forced air furnace or installed as new system.
- Complete package units are now available combining furnace, domestic hot water tank and controls in one housing.

### **Health issues**

#### *Advantages*

- Low temperature heat exchange reduces burning of dust.

#### *Disadvantages*

- Some may have comfort objections to continuous air movement.
- Especially in humid conditions, a cooling coil will condense moisture out of the air. This water has to drain away. If the system permits moisture to remain in the drip tray, this could be a source of mold.

### **General comments**

- Excellent retrofit for forced air furnace if equipped with additional filters.
- Available as heating or heating/cooling units.
- Can be very compact.
- Can be used to distribute ventilation air.

### **Maintenance requirements**

- Similar to furnaces with occasional filter changes, duct cleaning and fan motor service.
- If cooling is included, regular cleaning of condensate drain is essential.

### **Operating cost/savings**

- Cost depends on efficiency of heating/cooling equipment source.
- Multi-speed, high efficiency fan motor can reduce electrical energy consumption.

### **Product sources**

- Heating and ventilation contractors;
- furnace suppliers;
- commercial equipment manufacturers; and
- power utilities.

See also the sections on boilers, heat pumps and hot water tanks in this chapter and ventilation and air filtration in Chapter 4.

### **Furnaces**

Furnaces are classified by the fuel type they use and the way in which they operate. The most common furnace types are:

- electric;
- gas or propane; and
- oil.

#### **Electric furnaces**

From the perspective of indoor air quality, electric furnaces have the safest fuel type since there is no fuel that can spill or leak and there are no combustion gases which can escape into the home. The main disadvantage of electric furnaces is the burning of dust on the very high temperature heat exchanger. The odours produced can affect very sensitive individuals.

#### **Gas or propane furnaces**

*Though some very sensitive people cannot tolerate any gas appliances in a home, some find it acceptable to have a very well-isolated gas-burning furnace such as one with a sealed combustion or induced draft design.*



**Oil furnaces**

Oil handling and oil combustion are often associated with persistent air pollution, odours and flue gas pollution. It is virtually impossible to isolate an oil fired, forced air furnace completely from the home. In locations where there is no alternative fuel, the hypersensitive can use a high-efficiency oil-fired boiler for home heating and hot water if it is adequately isolated from the home and sealed in a separate mechanical room with a combustion air supply. See the boiler section in this chapter and the text on furnace retrofits in Chapter 5.

**General comments**

- Some condensing gas furnaces are available with high-efficiency electrically commutated motors (ECM). These are far more efficient multispeed motors than conventional furnace motors and will reduce fan operating costs.
- Belt-driven furnace blowers can be fitted with totally enclosed (TEFC) motors which reduce

odours and pollutants from motor insulation and lubricants.

**Maintenance requirements**

- Air filter change two to four times per year.
- Regular quarterly check of condensate drain on condensing units.

**Product sources**

Heating contractors.

See also the section on filters in Chapter 6.

**Heating/Air Conditioning Ducts and Connectors**

- Light gauge galvanized sheet metal or paintable anodized steel ducts (satin finish).
- Foil duct sealing tape or liquid latex seal (must be verified for the environmentally hypersensitive).

**Table 3:  
Furnace summary table**

Furnace Type	IAQ Advantages	IAQ Disadvantage	Efficiency Range	Operating Cost Range	Capital Cost Range
Electric	<ul style="list-style-type: none"> <li>• No combustion gases</li> <li>• No fuel to spill or leak</li> </ul>	<ul style="list-style-type: none"> <li>• Charred dust odours</li> </ul>	100% <sup>2</sup>	High, depending on utilities	Low
Naturally aspirated gas		<ul style="list-style-type: none"> <li>• Easily backdrafts</li> <li>• Odours from pilot light</li> <li>• Natural gas leakage possible</li> </ul>	65%	Medium	Low
Induced-draft gas	<ul style="list-style-type: none"> <li>• Some resistance to flue gas spillage</li> </ul>	<ul style="list-style-type: none"> <li>• Flue gas spillage possible</li> <li>• Natural gas leakage possible</li> </ul>	78 to 83%	Low	Medium
Condensing gas	<ul style="list-style-type: none"> <li>• Effectively resists flue gas spillage</li> <li>• No pilot odours</li> </ul>	<ul style="list-style-type: none"> <li>• Natural gas leakage possible</li> <li>• Plastic piping may be objectionable to some</li> </ul>	90 to 95%	Very low	High

**Notes:**

1. All forced air furnaces are likely to produce some odours from heated dust.
2. Though conversion of electricity to heat is 100 per cent efficient, electricity generation and transmission may be very inefficient, depending on the source.

- Mylar or foil-faced flexible duct.
- Extruded aluminium flexible duct.

#### Typical system applications

- Supply and return ducts for forced air heating and air conditioning systems.
- Sealers for duct joints.
- Vibration isolating duct connectors.

#### Installation considerations and options

- *All sheet metal ducts are preferred. Wood joists used as return ducts are difficult to clean and can also contribute odours to the air.*
- *New sheet metal carries oily residues. Washing with mild detergent or washing soda (sodium carbonate) is recommended.*
- *Flexible ducts offer higher resistance to airflow and may contribute emissions to the air especially when the air is heated.*

#### Health issues

##### *Advantages*

- Metal foil tape is generally less odorous than fabric tape or liquid duct sealers.
- Anodized steel duct materials may have less oily residues than conventional galvanized.

##### *Disadvantages*

- *Vinyl contents of some flexible components may not be acceptable due to odours and offgassing. Careful selection can minimize problems.*

#### Maintenance requirements

Periodic duct vacuum cleaning and inspection.

#### Product sources

Heating and sheet metal contractors.

See also the section on furnaces and fan coil units in this chapter and the text on ventilation in Chapter 4.

#### Hot Water Radiant Heating

Plastic or composite tubing carries water at 35°C to 70°C to heat floor or ceiling surfaces.

#### Typical system applications

Zoned heating of concrete floors or wood floors and ceilings.

#### Installation considerations and options

- Combined radiant/convection systems are common.
- Systems may be supplied by fuel or an electric boiler.
- Heated concrete slabs should have insulation at perimeter and beneath.
- Ventilation must be provided separately.

#### Health issues

##### *Advantages*

- Low surface temperature reduces burning dust.
- Good radiant comfort at lower air temperature and with minimum air movement.
- Radiators, which are often hard to keep clean, are unnecessary in this type of system.

##### *Disadvantages*

- Best used on floors with concrete or ceramic tile finish. Carpet, wood, gypsum and painted materials may outgas when warm.

### General comments

- *Low-odour plastic tubing is very important for the hypersensitive. Tubing that is exposed above the floor can contribute odours. Polybutylene or X-link polyethylene are generally acceptable.*
- *Hypersensitive individuals should ensure that the concrete contains no admixtures.*
- Recommended minimum slab insulation is RSI 2-3.2 (R12-20) at perimeter, and RSI 1-2 (R6-12) underneath.

### Maintenance requirements

None.

### Operating cost/savings

Typically, more costly to operate than forced air system due to heat loss through outside surfaces or ground.

### Product sources

- Specialized heating contractors; and
- plumbing contractors.

See also the section on boilers in this chapter.

### Humidifiers

Typically consist of wick and fabric or rotating drum units located in bypass airstream.

### Typical system applications

Add-on units for forced air systems in dry and cold climates.

### Installation considerations and options

- Water supply required.
- Floor drain near unit is recommended.

- Special automatic drain and flush valves are available which reduce maintenance requirements.
- “Cool mist” units are an option. These vaporize water using ultrasonic energy.
- Steam type are also an option, but at high energy cost.

### Health issues

#### Advantages

- Increased humidity during heating season can relieve respiratory irritation and reduce airborne dust.
- The need for a humidifier should be assessed first. Take relative humidity readings with a hygrometer. The relative humidity should not exceed 45 per cent.

#### Disadvantages

- Risks of microbial contamination cause many to avoid these units except when conditions are very dry. Unless the house envelope, especially the windows, is well insulated, condensation will occur in cold weather.

### General comments

- Portable humidifiers and humidifier/filter warm air registers (floor grille replacements with water reservoir and fabric filter) are possible options.
- “Cool mist” units should only be operated with sterilized, demineralized and filtered water.

### Maintenance requirements

Humidifiers must be cleaned and checked regularly.

### **Operating cost/savings**

Steam types use a great deal of electricity (about 1,500 watts).

### **Product sources**

- Heating contractors;
- furnace manufacturers; and
- humidifier manufacturers.

See also the section on furnaces in this chapter.

### **Isolated Fan Motors**

Totally enclosed motors are sealed units. Windings, insulation and bearings are not exposed to the air.

### **Other common names**

- TEAO (totally enclosed air over) motors;
- TENV (totally enclosed non-ventilated) motors; and
- TEFC (totally enclosed fan cooled) motors.

### **Typical system applications**

As a replacement motor for furnace, fan-coil or heat-pump fans. Belt-drive fan motors are more easily replaced than direct-drive types.

### **Installation considerations and options**

Replacement of direct-drive type furnace fans can be difficult, requiring custom mounting brackets and parts, or not possible due to non-compatibility with furnace control system. Space constraints may also be a problem.

### **Health Issues**

#### *Advantages*

- *Sealed motors expose less insulation, plastic and oily bearings to the airstream.*
- *Totally enclosed motor retrofits may be helpful for adapting warm air systems for the hypersensitive.*

### *Disadvantages*

- *Totally enclosed motors may not allow speed control.*

### **General comments**

High-efficiency models not as readily available.

### **Maintenance requirements**

Minimal, totally enclosed motors usually do not require lubrication.

### **Operating cost/savings**

Similar operating cost to conventional motors.

### **Product sources**

Electrical, machinery and agricultural suppliers.

See also the section on furnaces and fan coil units in this chapter.

### **Low-Temperature Convection Heaters**

Baseboard-type heaters using hot water supplied at 75°C to 95°C. Also liquid-filled electric baseboards or low-watt density electric baseboards (typically less than 400 W/M).

### **Other common names**

- Hydronic heating (hot water);
- liquid-filled electric heaters; and
- low-watt density electric baseboard heaters.

### **Typical system applications**

Zoned space heating.

### **Installation considerations and options**

Requires hot water boiler or adequate electrical supply (electric units). Usually zone or single room controlled. Ventilation must be provided separately.

## Health Issues

### Advantages

- Lower surface temperature reduces burning dust.
- Zoned operation allows isolation of rooms, that is, no air mixing between rooms.
- Liquid-filled electric variety is particularly useful for isolated retrofits of one room or suite, where a forced air system is found unacceptable.

### Disadvantages

Air filtration is not possible.

### General comments

- A 460-volt industrial convectors will operate as low-watt density if supplied at 230 volts.
- Should not be turned down too low in winter or moisture damage may occur in closed rooms.

### Maintenance requirements

Occasional cleaning.

### Operating cost/savings

- Hydronic unit operating costs depend on boiler equipment.
- Electric units are similar to other electric heating.

### Product sources

- Heating and ventilation contractors;
- electrical contractors;
- specialty manufacturers; and
- plumbing contractors.

See also the sections on boilers and portable heaters in this chapter.

## Low-Temperature Portable Heaters

- Low watt density or liquid-filled baseboard-type convector or liquid-filled radiator type.
- Generally 120 volt, 1,500 watt maximum.
- Includes thermostat and safety shut-off.

### Typical system applications

Convection heating of single rooms or small areas.

### Installation considerations and options

- A separate 120V 15A electrical circuit required for each heater.
- Do not use extension cords.

## Health issues

### Advantages

- Low surface temperature reduces burning dust.
- Good radiant comfort at reduced air temperature (with large radiator types).
- *Good retrofit solution for a special sanctuary room.*

### Disadvantages

- *Special heater finishes may be required (i.e., stainless steel or baked enamel). Plastic, rubber or painted parts are generally not acceptable to the hypersensitive.*

### General comments

- Must have tip-over safety protection (safety shut-off).
- Inexpensive solution for renters.

- Do not use fuel-operated portable heaters. These may produce combustion gases.
- Some people find fan-operated, ceramic units acceptable.

#### **Maintenance requirements**

- Occasional check of electrical cord and plug.
- Occasional cleaning.

#### **Operating cost/savings**

Same as other electric heating.

#### **Product sources**

- Specialty heating suppliers; and
- allergy product services.

See also the section on low-temperature convection heaters in this chapter.

#### **Passive Solar Heat**

Primarily south-facing glazing, high-performance windows and usually an air circulation system. May also require massive materials for storage.

#### **Typical system applications**

As a supplementary heating source in sunny regions.

#### **Installation considerations and options**

- Requires an appropriate climate and unobstructed solar exposure.
- Careful design, window sizing and selection are essential.
- High insulation levels are important.
- Ventilation and air filtration must be provided separately.

#### **Health issues**

##### *Advantages*

- No fuel consumption, no mechanical equipment and low temperature surface heating.
- Enhanced daylight and sunlight exposure in interior spaces.

##### *Disadvantages*

- Heat storage surfaces should be finished with low-emissions materials (i.e., concrete, brick or ceramic).

#### **General comments**

Air circulation between rooms is usually necessary to distribute heat. This makes it difficult to maintain air quality zones.

#### **Maintenance requirements**

None.

#### **Operating cost/savings**

Solar energy is free. With high-performance windows, heat losses are minimized. Twenty to forty per cent solar heat is possible in some climates with appropriate design.

#### **Product sources**

- Solar design consultants;
- energy efficiency consultants; and
- builders with solar design experience.

### **Portable/Window or Wall Air Conditioners and Compact Split-System Air Conditioners**

- Housing containing refrigeration system and air circulating fan. Usually has outside air intake and basic filter.
- Split units have a remote mounted compressor. These are quieter and more efficient.
- Portable units are available which are installed in a hole in the wall or in a modified window opening.

#### **Typical system applications**

- Single room cooling and dehumidifying.
- Some units may have heating capability.
- Most units have ventilation ability.

#### **Installation considerations and options**

- Separate electrical circuit is required.
- Condensate drain is required.

#### **Health Issues**

##### *Advantages*

- Dehumidifies to control mold and dust mites.
- Can provide ventilation if required with air intake.

- Can provide basic air filtration.
- Allows “windows closed” conditions where outdoor air is unacceptable.

##### *Disadvantages*

- Risk of contamination of condensate system.
- Noisy when operating (split units are quieter).

#### **General comments**

Sometimes the only available means of providing comfort in a room or apartment in hot, humid conditions.

#### **Maintenance requirements**

- Condensate system and unit must be kept clean and sterile to prevent microbial growth.
- Regular cleaning.
- Winter shut down.

#### **Operating cost/savings**

- Less efficient than typical central heat pumps.
- Air leaks around window units add to heating and cooling costs.

#### **Product sources**

- Department and hardware stores; and
- appliance dealers.

## 4. Ventilation and Filtration Basics

---

Ventilation is the removal of stale air and excess moisture from the occupied zones of the house, and the introduction of outdoor air to dilute indoor air contaminants. Ventilation should be distinguished from air filtration and air cleaning. Only systems which remove air from the home or supply outside air to the home are referred to as ventilation systems.

Mechanical ventilation will:

- provide reliable control over air exchange if the house is fairly draft free with a continuous air barrier;
- improve indoor air quality under all circumstances except where outdoor air quality is worse than the indoor air quality;
- reduce indoor relative humidity levels in winter when applicable and thereby reduce surface condensation on windows and other cold surfaces; and
- possibly increase the need to supply combustion air for fuel-burning appliances.

Mechanical ventilation will not:

- be an appropriate method to supply combustion air to fireplaces, wood stoves and other fuel-burning appliances, which require a separate, dedicated combustion air supply;
- remove all indoor air pollutants such as smoking, odorous hobbies, pets or other unusual odour sources which exist in a home;
- effectively filter room air;
- do much to cool the house in summer or heat it in winter;
- guarantee freedom from condensation; and
- operate for free. Ventilation air must be heated in the winter and cooled in the summer, increasing operating costs.

### Exhausting Pollutants at Source

Concentrated moisture and air pollutants are generated by cooking, bathing, laundry and hobby activities. These will disperse throughout the

home if not removed at their source. Locating effective exhaust fans which remove air from as closely as possible to the point where pollutants are generated is an essential part of a ventilation strategy. Exhaust may be by a simple local fan, such as a kitchen range hood, or it may be through a ducted central ventilator or heat recovery ventilator, drawing from bathrooms and laundry. Exhaust can also be drawn from the closets to remove odours from stored clothing and household goods.

### Natural vs. Mechanical Ventilation

Ventilation in housing has traditionally been provided by natural means such as opening windows or through leaks in wall construction. While this approach has an appeal due to its simplicity and low construction costs, it has the disadvantage of relying on thermal effects (the stack effect) or wind to move air. Both of these forces vary with weather conditions. The stack effect is strongest during winter when the outside air temperature is low. In late spring, summer and early fall when the outside air temperature is warmer, the stack effect is weak or non-existent. Wind on most sites is highly variable all year and cannot be relied on for continuous and reliable ventilation. In addition, the random holes and cracks in walls, floors and ceilings do not ensure that all rooms are adequately ventilated. Uncontrolled leakage can cause uncomfortable drafts.

A complete mechanical ventilation system exhausts and supplies ventilation air in a controlled manner. Outdoor ventilation air is brought in by ducts where it is easily filtered, tempered, distributed and its rate of supply controlled (Figure 26).

### Ventilation Effectiveness and Distribution

Ventilation effectiveness is a measure of the quantity of outside air actually delivered to



Figure 26:  
Comparison of Natural and Distributed Mechanical Ventilation

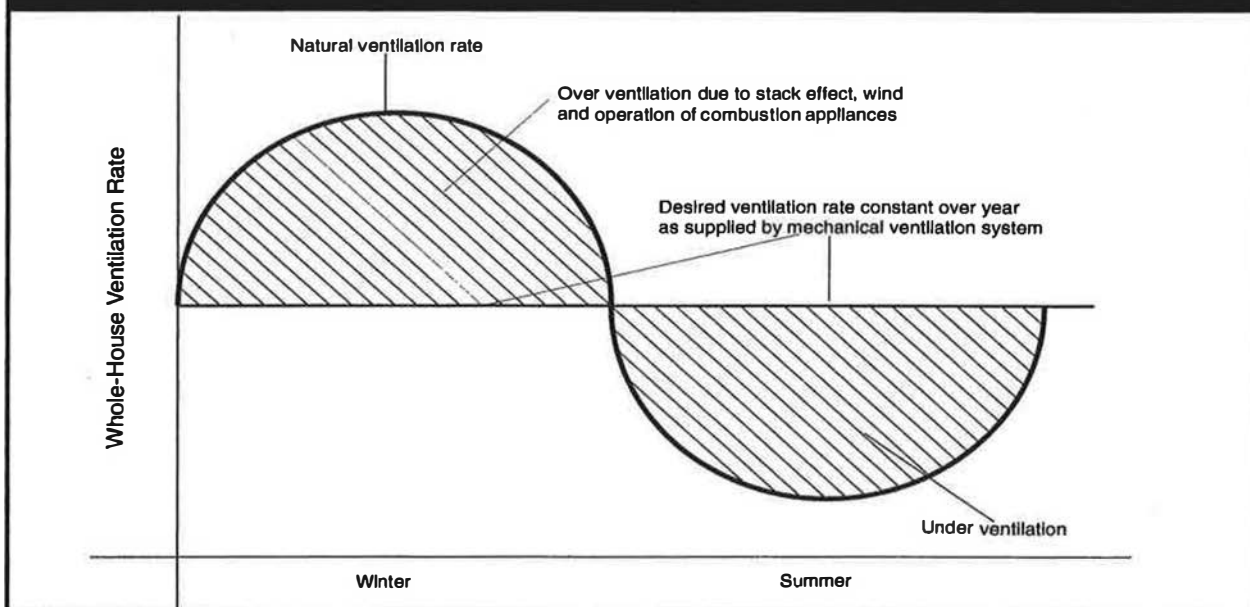

occupants as a proportion of what is actually brought into the home. The most effective ventilation system is one which introduces air at one extreme point in an occupied room and allows the air to sweep through the occupied zone and exit to an exhaust at another extreme point of the room. Because the floor and ceiling of a room are not zones where people breathe, ventilation air is often introduced at a high point and exhausted at a low point, such as under a door (Figure 27). The air must pass through the middle zone of the room. *In some cases, for the environmentally hypersensitive, both a supply diffuser and an exhaust grille are provided in every room of the home to ensure ventilation effectiveness.*

Ventilation distribution is a measure of the degree to which ventilation actually reaches all occupied parts of the home. A fully distributed ventilation system is one which supplies or exhausts air from every room of the home. It is always superior to one that exhausts air from only one location and supplies air into only one location in a dwelling.

In displacement, or stratified ventilation, air enters near floor level at a low enough velocity not to cause a draft. This arrangement minimizes air circulation in the space and permits stale or

polluted air (air exhaled from room occupants and the air surrounding offgassing appliances) to rise to the ceiling to be exhausted. Because these pollutant sources are typically warmer than their surroundings, the immediately surrounding air warms and rises. As a consequence, it is possible to achieve the same removal of air pollutants from a space with a lower than normal airflow, with resultant energy savings. Furthermore, the slow-moving air does not stir up as much dust.

### Ventilation System Operation

Ventilation systems can operate continuously or intermittently. The typical kitchen range hood that is switched on only during cooking is an example of intermittent ventilation. A heat recovery ventilator, on the other hand, may operate 24 hours a day, supplying fresh air and exhausting stale air from the home. Intermittent ventilation is best used to exhaust moisture or pollutants from the home that are generated in large quantities for short periods of time. Continuous ventilation is better suited for diluting and exhausting pollutants that are released in smaller quantities continuously; for example, pollutants and odours emitted from household goods and moisture released due to human

Figure 27:  
Ventilation Effectiveness

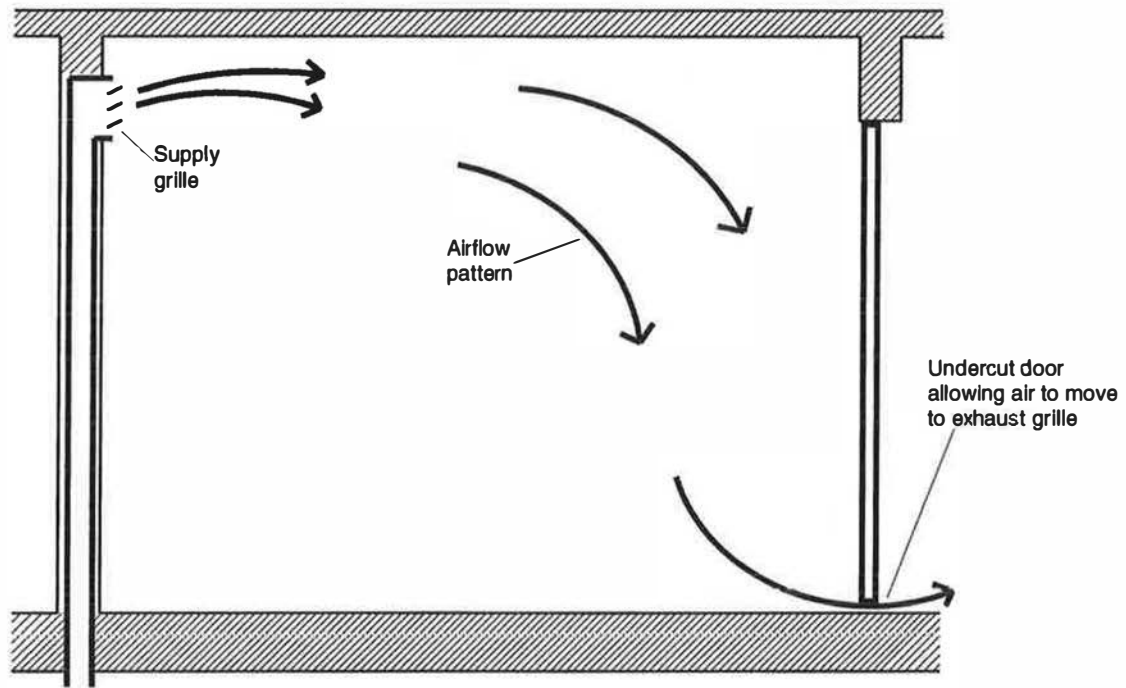

Cross Section of Room

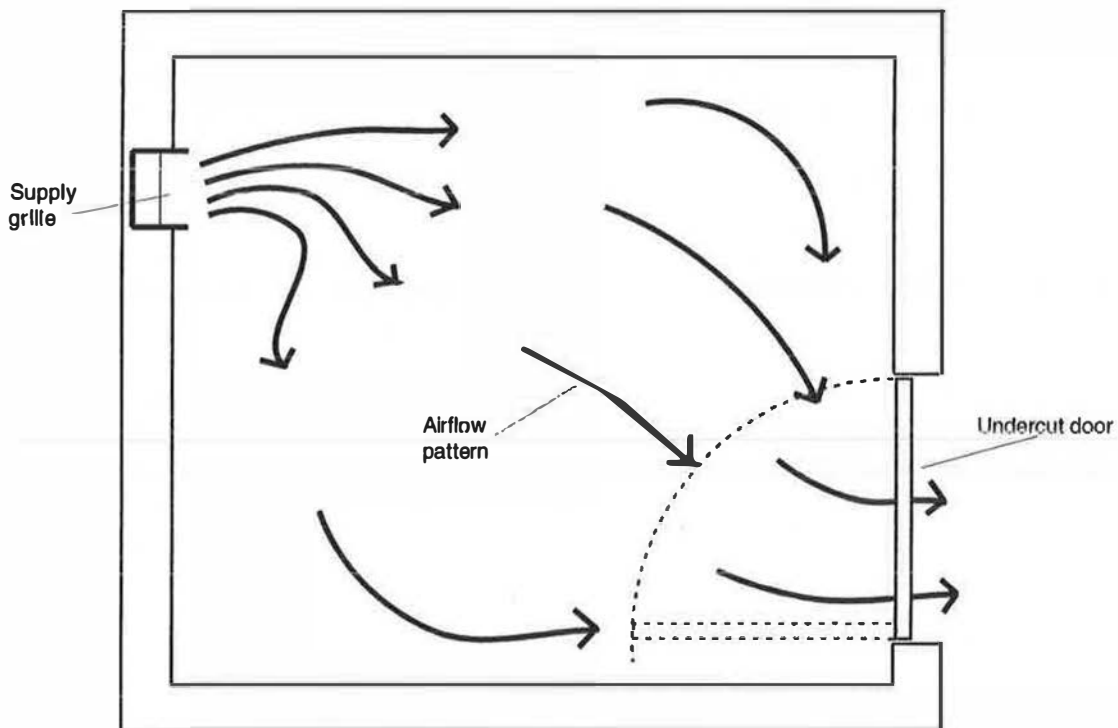

Plan View of Room

respiration. Continuous ventilation rates are typically lower than those for intermittent ventilation. For example, range hoods with capacities of 70 to 250 L/S (148 to 530 cfm) are common for intermittent ventilation, while HRV systems operate anywhere from 25 to 100 L/S (50 to 225 cfm) for the entire home. Continuous ventilation systems should be provided with at least two fan speeds to provide an appropriate ventilation rate, control energy use, reduce noise and extend equipment life. Intermittent ventilation also should have air volume controls for similar reasons.

### **Applications of ventilation systems for the environmentally hypersensitive**

*Strategies to achieve clean indoor air typically incorporate a ventilation system with ducted supply and exhausts to ensure air exchange in all occupied rooms. The system will usually have heat recovery to improve comfort and reduce operating costs, and it may incorporate special filtration methods. Though these are good ventilation strategies for any home, there are some special considerations for the environmentally hypersensitive.*

### **Ventilation rate**

*Residential ventilation standards are set primarily for humidity control and to maintain reasonable comfort conditions. Recommended rates are at least 5 L/S (10 cfm) per occupied room. This minimum standard may not necessarily provide the best conditions for those with special health requirements. Because increasing the ventilation rate can improve air quality to a degree, many houses for the hypersensitive are equipped with ventilation systems which are considered oversized by most standards. There is no particular rule of thumb for this, nor is it expected that these systems will be operated at full capacity most of the time. In fact excessive ventilation can cause very low humidity in cold weather and other aggravating health and comfort conditions. The goal is to have additional capacity to use as needed, to have very thorough*

*and effective exhausts, and to have well-controlled and filtered supply air.*

### **Ventilation system design**

*There are special things to consider when designing ventilation systems for the environmentally hypersensitive.*

- *Ideally, ventilation should be independent from the heating system so air mixing between rooms can be minimized.*
- *There should be ducted ventilation air supplies to occupied rooms, especially bedrooms and other rooms where people spend a lot of time.*
- *Exhausts are often taken from storage closets as well as baths, kitchens and hobby areas to extract odours from these areas.*
- *Sometimes a single room or suite in the home is served by a separate ventilation system. This is often called a sanctuary room.*
- *Special exhausts may be included for removing odours and pollutants from library shelves, televisions, computers and reading boxes (boxes for isolating odorous printed materials). These are ducted through an HRV in some cases.*
- *The outside air intake must be located in the safest place possible, away from local air pollution sources, such as chimneys, exhaust vents, plumbing vents and vehicle exhausts.*
- *Special filtration for particle and gas removal should be considered for the supply airstream after the ventilating unit.*
- *All system materials and indoor finishes, materials, adhesives and furnishings must be carefully selected for minimal offgassing.*
- *Easy access for regular cleaning.*

### Ventilation system materials

*Some of the materials often acceptable for the environmentally hypersensitive are:*

- *sheet metal ducts and fittings with oily residues removed by washing;*
- *metal foil heating duct tape for duct joints; and*
- *zinc electroplated sheet metal (satin coat) ductwork, if cleaned of any oily residue.*

*Materials which should be avoided are:*

- *plastic or fibreglass ducts and system components;*
- *plastic duct tape; and*
- *sealants and gaskets containing solvents, butyls, polychloroprenes, sulphonated rubber and other odorous materials. (Water or latex based liquid duct sealers may be acceptable. Check for individual sensitivity.)*

### Special ventilation equipment

*Some of the special equipment often used for the environmentally hypersensitive includes:*

- *high-performance pleated filters, carbon filters and other gas removal filters;*
- *special HRVs, with housings made from stainless steel or porcelain steel (these may be particularly expensive);*
- *HRVs with metal heat exchange cores or aged plastic cores (those which have been cured in a heated chamber to reduce odour); and*
- *single room ventilator units or compact, wall- or window-mounted units.*

## Types of Mechanical Ventilation

### Supply-only systems

Supply-only ventilation is a method of ventilation in which only outdoor ventilation air supply is provided mechanically and is not mechanically exhausted (Figure 28). A naturally aspirated furnace with an outdoor air supply into the return air plenum is a common example. This

is typically not a recommended system in a draft-sealed house because it carries the risk of house pressurization leading to excessive air leakage and the potential of moisture damage.

### Exhaust-only systems

In exhaust-only ventilation, the exhaust is provided mechanically; the supply air is drawn in through cracks and holes in the building envelope, or through passive wall diffusers (Figure 29). A typical house with kitchen and bath fans, or a central exhaust ventilator is a common example. Exhaust-only systems generally have the disadvantages of poor control over the supply and distribution of ventilation air as well as an inability to filter incoming air. Exhaust-only systems can also cause back venting of combustion appliances and entry of soil gases unless preventive measures are taken. With these systems, the supply air is brought in by one of three means.

#### *Natural leakage*

Air moves inward through openings, cracks and air-permeable materials in the building envelope to replace air extracted by the exhaust system. It is virtually impossible to filter or adequately control this type of supply. For this reason exhaust-only systems relying on natural leakage for supply air are not recommended.

#### *Through-wall slots*

These are passive air supply devices for exhaust-only systems. They are thin ducts with narrow diffusers, usually made of hard plastic, which are mounted near the ceiling. They usually incorporate insect screens and a primitive fibre or foam filter. In winter, outdoor air must mix with warmer room air before reaching the occupied zone, thereby reducing comfort complaints. Studies in Scandinavia have shown that even in very airtight buildings, through-wall slots will only contribute 50 per cent of the supply air. The remainder is supplied through random cracks and holes in the building envelope. Wall slots must be carefully selected and located to avoid cold drafts

Figure 28:  
Ventilation—Supply Only

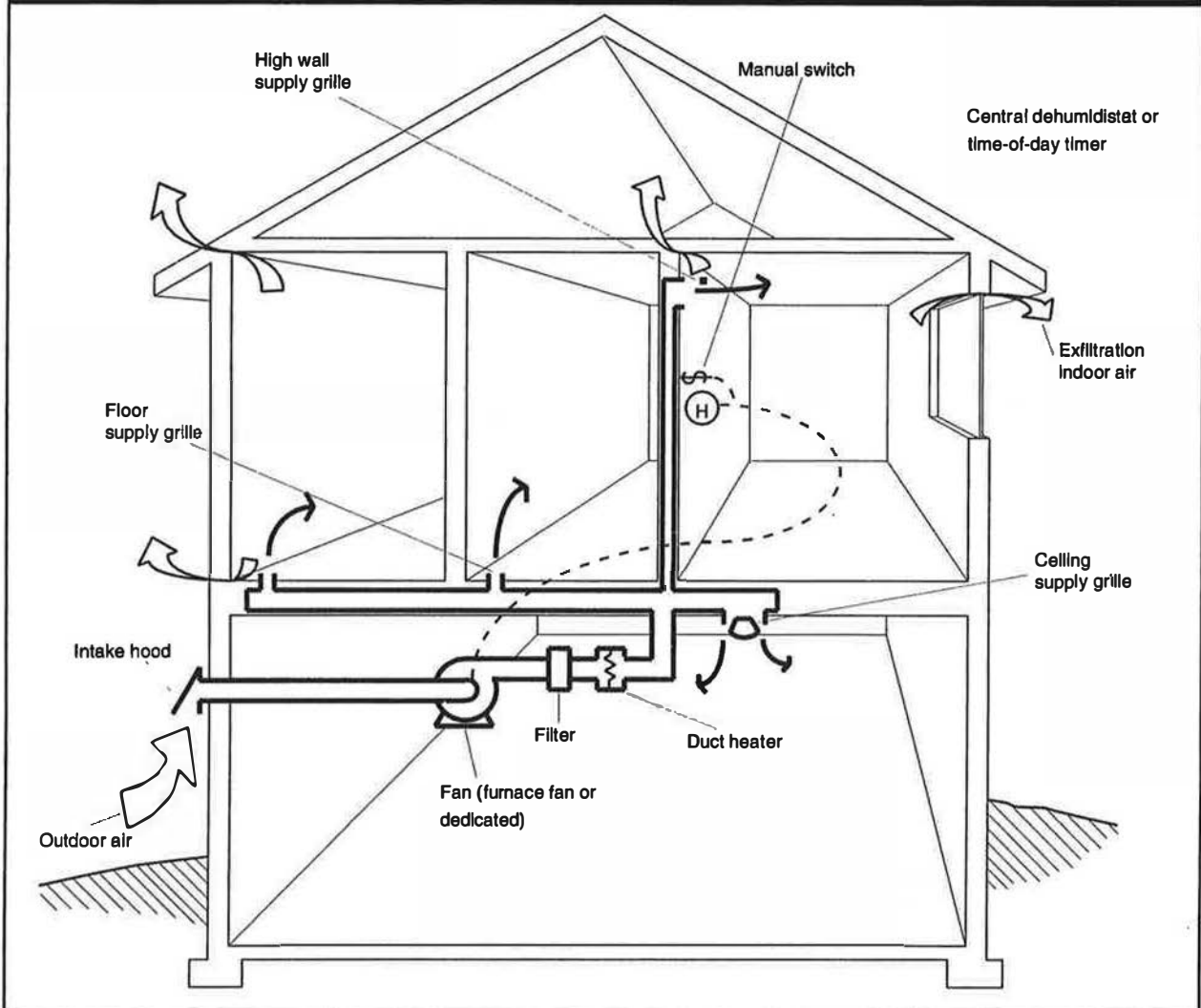

and are not suitable for many Canadian climates (Figure 30).

***Distribution through a forced air heating system***

Typically, an outside air intake is connected to the return air path of the furnace/air conditioner providing a path for supply air through the forced air supply duct system, as the building is depressurized by the exhaust fan. This air is mixed with return air, heated or cooled, and delivered to rooms through the forced air system. If this system is used, then passive wall intake slots would not be used.

**Local exhaust fans**

Bathroom fans are the most common type of ventilation equipment found in Canadian housing. These fans can range from noisy, economy models, to units that are designed for low noise operation and can run for extended periods of time. The better bath fans are referred to as “low-sones” models in reference to their low noise rating. Only low-sones (2.5 sones or less) fans should be used, because their quieter operation allows them to be operated more frequently and for longer periods without causing annoyance. For long life in continuous operation, commercial-grade, cabinet-type, in-line duct fans

Figure 29:  
Ventilation—Exhaust Only

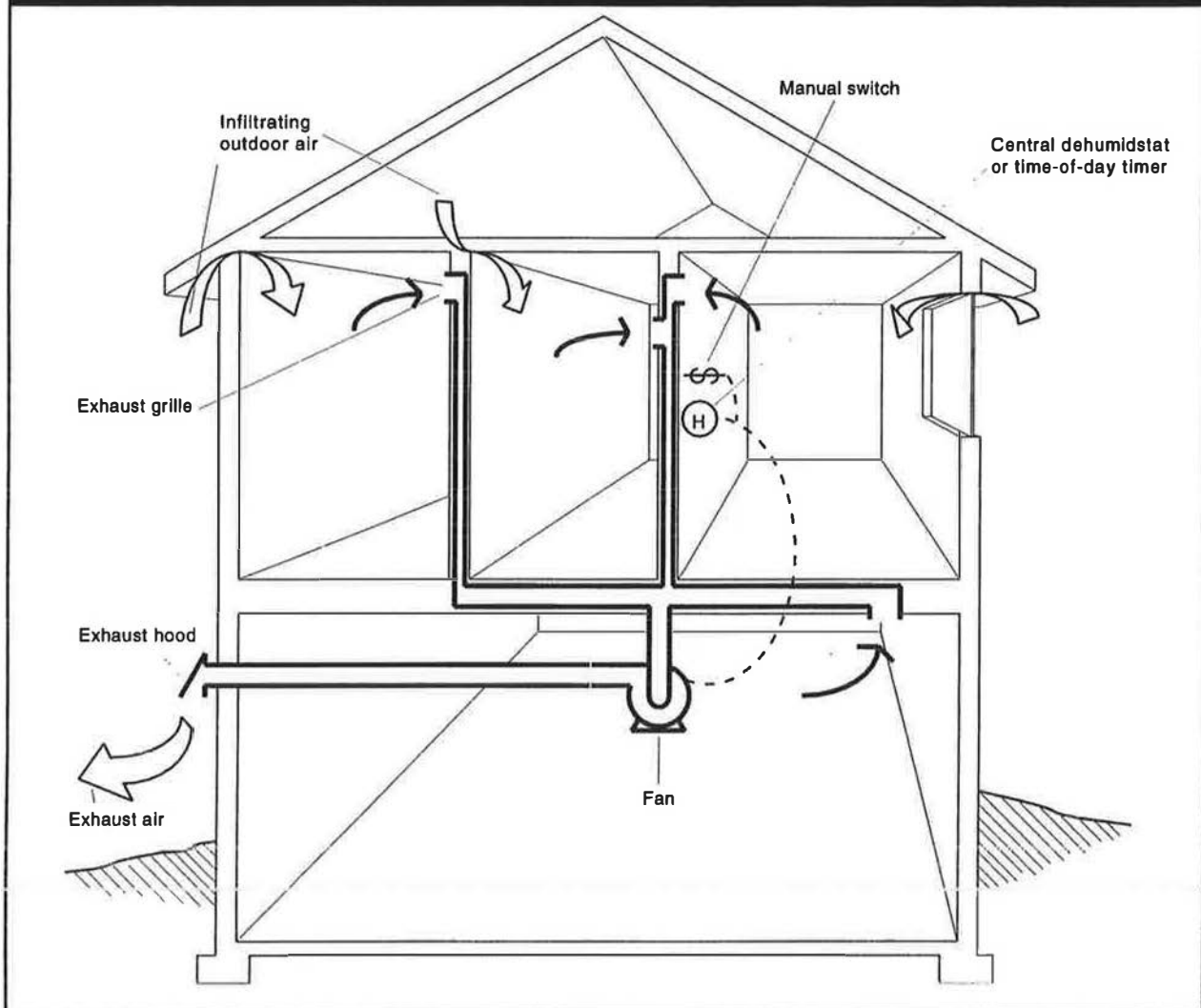

are often a good choice, since they may incorporate better fan and motor bearings, more efficient motors and quieter operation.

Bath fans have airflow capacities usually in the range of 25 L/S to 50 L/S (53 cfm to 106 cfm) although some are made as large as 150 L/S (320 cfm). Due to recent ventilation requirements in the national and provincial building codes, more low-sone fans are being used and, in some cases, one of these fans (usually in a bathroom) will form the primary ventilation system in the home. This is referred to as a whole-house fan, and is a type of exhaust-only ventilation. Whole-house, fan-based ventilation systems may rely on

supply air being provided by random leakage through the building envelope, by way of a duct into the return air plenum of a forced air furnace, or wall venting slots. Code revisions in the 1995 *National Building Code* make ducted supply air a requirement for these systems.

### Duct sizing

For an exhaust fan to operate effectively, it must be installed with correctly sized ductwork. If the duct is too small in diameter, too long, or has too many turns, it will restrict airflow and not allow the fan to move as much air. A flexible duct produces much more resistance to airflow than

Figure 30:  
Passive Wall Inlet

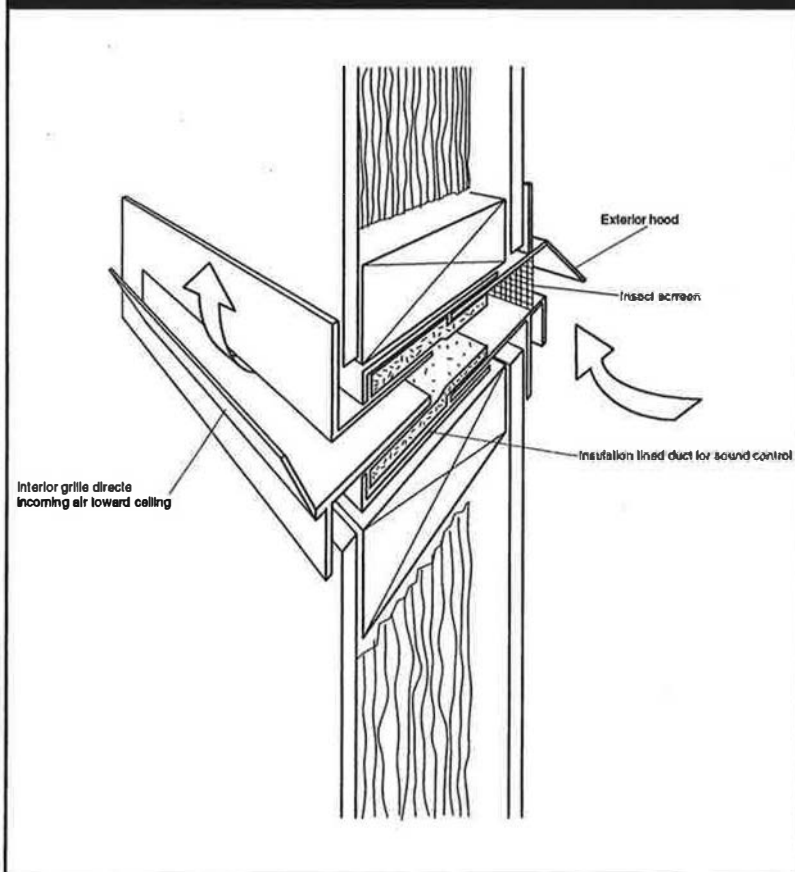

a rigid duct and should be used only where it has been verified that it will provide adequate flow with the fan installed. To ensure proper duct sizing, use Table 4 or follow the recommendations of the manufacturer or local building code.

**Cabinet or in-line duct fans**

In some applications, fans cannot be conveniently located in ceilings or walls the way bathroom fans are. One special fan type is the cabinet or in-line duct fan. It is built into a housing with fittings for inlet and outlet duct connections. It can be located almost anywhere in the duct as long as it is not exposed to weather. Inlet and outlet connections may be varied to suit the application. These are generally very high quality, low-noise fans designed for continuous operation. A common application is in a radon control system, though these fans are also used for general purpose ventilation. An exhaust system using a duct fan located remote from the room served will be very quiet and reliable.

Table 4:  
Duct sizing

Maximum Capacity of Exhaust Fan *		Duct Diameter			
		Smooth		Flexible	
L/S	CFM	mm	Inches	mm	Inches
10	21	75	3	100	4
25	53	100	4	125	5
45	95	125	5	150	6
70	147	150	6	175	7

Notes:

- \* The ventilation capacity of residential exhaust fans is usually rated by the manufacturer at 50 Pa. (0.20 in WC) static pressure.
- 1. Maximum duct length of 15 m (50 ft.).
- 2. Maximum 2 x 90° elbows (or increase one diameter)
- 3. Flexible duct length should be kept to 1.5 m (5 ft.) total or less.

**Outside exhaust hoods**

Exhaust hoods are mounted at the outdoor outlet of the exhaust duct. The exhaust hood provides weather protection and prevents birds, rodents and insects from entering the ductwork. The design of the exhaust hood can also affect the amount of air a fan can exhaust from the home. Many hoods with hinged dampers, or those with small caps, are very restrictive. The better hoods have large covers for less restriction and counterweighted dampers.

### **Condensation in ductwork**

Condensation can form in ductwork when warm moist air from the home passes through a cold duct. Condensation in or on ductwork can lead to mold growth. Water dripping through the fan grille can block the duct completely. To prevent condensation formation, all ductwork passing through unheated spaces should be insulated with a minimum of 50 mm (2 in.) of foil-faced insulation (RSI 0.7). In addition, the ductwork should be sealed at all joints with a liquid sealer or foil tape to prevent warm moist air from leaking into unheated spaces, leading to condensation on the house structure. It is wise to slope all exhaust ductwork toward the outside hood to allow any condensate to drain to the outside. The exhaust hood should not be placed over an entryway or sidewalk where ice could form. In colder climates, ducts should be kept inside the heated envelope.

### **Exhaust fan controls**

Exhaust fans are typically controlled with a standard light switch, though in many cases, a more sophisticated fan control is desirable or required by code.

#### ***Dehumidistats***

A dehumidistat is a control that activates an exhaust fan or ventilator when the humidity in the home rises above the set point. The dehumidistat will then continue to operate the fan until the humidity is brought down past the set point (Figure 31). For a dehumidistat to service an entire house, it must be centrally located in an occupied area, 1.5 m above the floor. For most climates during the heating season, dehumidistats should be set between 40 and 60 per cent relative humidity. In summer, they may be switched off or set at 80 per cent. Dehumidistats may also be wired to the furnace fan to operate the supply fan in the case of forced air systems. In the case of a continuously operating ventilation system, the dehumidistat may be used to switch from low to high speed. In such an installation, the dehumidistat can be

located in the exhaust airstream (e.g., as in the HRV). Some HRVs have a dehumidistat already installed to switch the machine between high and low speeds.

**Figure 31:**  
**Dehumidistat**

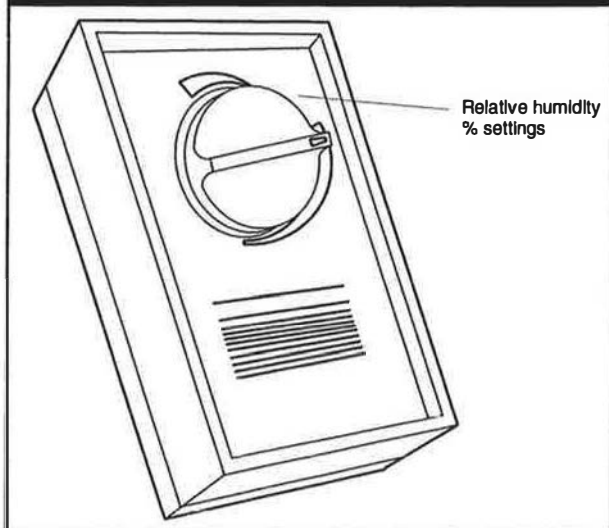

#### ***Timer switches***

These are also known as crank timers. They are often used in bathrooms to allow for switching bath fans on for periods from five minutes up to one hour. They may be mechanical or electronic. These are better than a standard switch because they prevent the ventilator from running when not required. Mechanical timers may be noisy, deterring their use by occupants.

#### ***Time-of-day timers***

Time-of-day timers usually have a 24-hour clock which can be programmed to switch exhaust fans on and off for predetermined periods. These allow a fan to shut down during unoccupied periods but to start before the occupants return home to help flush stale air from the house.

#### **Capital cost**

The capital costs of a properly installed exhaust fan in a bathroom are in the range of \$200 to \$400 making it one of the least-costly ventilation



systems available. Cabinet fans are generally more costly than bath fans.

### **Operating costs**

The power consumption of small fans ranges from about 30 watts to 150 watts. This makes the cost of electricity for operating the fan a relatively small factor. However, heated or cooled air which is exhausted through the fan must be replaced by outside air which is usually heated or cooled. The cost of conditioning incoming air is the major cost of exhaust fan use.

### **Maintenance and replacement**

Low-sones fans require little or no maintenance over their life. In order to be quiet, they use higher-quality bearings or operate at slower speeds than conventional exhaust fans and may, for this reason, have a longer life. The actual life of a good fan will vary from about five to 10 years depending on use and conditions. Replacement of the fan can usually be done without removing the housing. Access to allow future maintenance must be considered in any design.

### **Applications for the environmentally hypersensitive**

*The function of exhaust fans, removing odours and excess moisture from the home, is critically important for the environmentally hypersensitive. Exhaust fans should be used for any room with intermittent heavy pollutant sources (e.g., kitchen ranges, baths, showers, photography chemicals) to remove pollutants before they spread to other areas. Exhaust fans should be high-capacity units, with well-designed discharge ducts to reduce restrictions. However, exhaust fans alone do not make a complete ventilation system. Control and distribution of supply air are critical. See the text on heat recovery ventilators in this chapter.*

*In some circumstances for the environmentally hypersensitive, specially dedicated exhaust fans will be used in addition to the usual bath and kitchen exhausts in the home, regardless of the*

*ventilation system type. Typical examples are exhausted fume hoods or enclosed boxes for computers, televisions, stereos, reading materials, ironing, darkrooms and other hobbies. As long as these are moderate-capacity units of less than about 100 L/S (212 cfm), they will not usually interfere with building air pressure and cause unexpected air leakage or backdrafting in a typical home, unless more than one exhaust is operated at once.*

*The environmentally hypersensitive may spend a great deal of time indoors and are often more aware of noise than others. For this reason, all ventilation equipment should be good quality, low-noise designs, rated for continuous use. A good rule of thumb for exhaust fans is that they should be centrifugal blowers rather than propeller type, and should be rated at 2.5 sones or less.*

*If the house has a combustion appliance, it is advisable to install a CO detector, as a safeguard to depressurization, pressurization and combustion gas leakage. The CO detector is referenced in the 1995 National Building Code relating to solid fuel appliances. However, under some applications, these may be recommended for installation.*

### **Kitchen range hoods**

#### ***Updraft type***

The most common type of kitchen exhaust is the updraft hood or range hood. It is simply a sheet metal housing, usually containing a light, controls, an exhaust blower and a duct leading outside. The unit must contain a grease filter, be of non-combustible construction and be mounted at least 600 mm (24 in.) above a cooking surface (Figure 32). The blower may be mounted in the hood, in the duct or outside on the wall or roof. As with any other electrical equipment sold in Canada, any kitchen exhaust unit installed in Canada must bear a CSA approval stamp or be an approved equivalent. Due to poor design, most basic range hoods are not very effective. Side baffles from the hood down to the range

surface can help in special circumstances and can be installed by the occupant.

**Downdraft type**

Many kitchen cook tops and grilles are equipped with an exhaust unit built into the work surface. These are called downdraft, because they extract air in a downward direction. Their main advantage is that they can be used on a kitchen island where there are no upper cabinets to install a range hood. These units can be fairly quiet if equipped with a remote mounted blower, but they are not as effective as an updraft hood of the same capacity. They require much more exhaust

capacity to do the same job, and do not work well with tall pots, because the rim of the pot is above the effective exhaust zone. One option for island installation is a cook top with a retractable hood. These are slim exhaust units which pop up behind the cooking surface when it is in use and retract to a flush position when switched off. They are more effective than downdraft units and can function with tall pots.

**Exhaust capacity**

The appropriate fan capacity for a range exhaust unit depends on the type and design, and the type of range it serves. The usual high-speed capacity

Figure 32:  
Range Hood Ventilation System

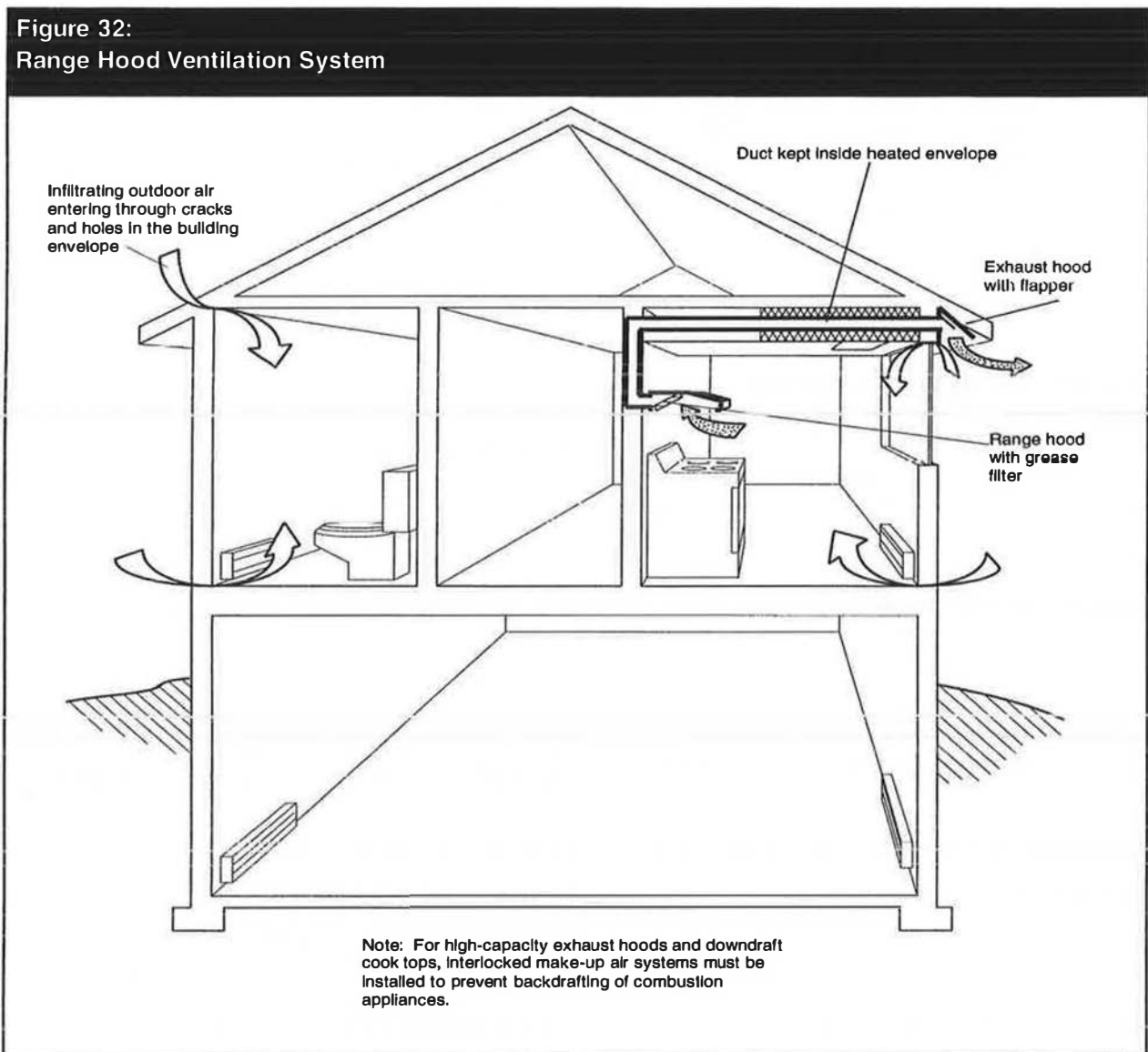

for a well-designed range hood with a built-in fan is about 150 L/S (318 cfm). Some of the most effective hoods with remote-mounted blowers have a maximum capacity of about 400 L/S (850 cfm). Those which are carefully designed and have less restrictive grease filters and ducts can operate with less airflow. Downdraft exhausts always require at least 300 L/S (635 cfm) to operate effectively. These high-capacity models must be carefully considered in relation to fuel-burning equipment in the home, due to their ability to cause backdrafting of flues.

All units, regardless of size, should have a speed control to allow quieter operation at moderate speed and to control cold drafts and house depressurization. High speed is usually only used for extreme situations such as burnt food.

#### **Ductwork**

Only rigid sheet metal ducts are appropriate for range exhausts. The duct size should not be reduced below manufacturers' specifications. Duct runs should be kept short and with a minimum of bends. All joints should be securely sealed with foil duct tape to prevent leakage and any duct sections passing through unheated spaces must be insulated to reduce condensation. Due to the risk of grease accumulation, the *National Building Code* requires that the duct be accessible for cleaning. Should the duct not be accessible, a grease filter must be provided at the range hood or the exhaust grille at the entrance of the duct.

#### **Capital cost**

A basic, effective kitchen range hood with a variable speed control and a moderately quiet blower of about 200 L/S (425 cfm) capacity will cost about \$350 to \$500 installed. High-capacity units with remote blowers and downdraft units will usually cost from \$700 to \$1,800.

#### **Operating costs**

Fan operation is a small part of the operating cost of a kitchen exhaust. However, large-capacity units used extensively in winter will substantially increase heating costs. The actual amount is widely variable depending on local weather and conditions.

#### **Maintenance**

All kitchen fans require periodic cleaning of the grease filter and hood surfaces. The frequency will depend on the type of cooking done. Oily deposits which are not removed will tend to become rancid causing odours and will eventually harden. A sodium carbonate (washing soda) and hot water solution is an effective and reasonably safe cleaning material. Many people wash the grease filter in a dishwasher. Stainless steel filters are available, easily cleaned and durable.

#### **Applications for the environmentally hypersensitive**

*The kitchen exhaust fan is critically important for those sensitive to inhalants. Cooking and small appliance use produces a wide range of odours and pollutants including occasional, accidental burning of spilled food. A kitchen must have direct and effective exhaust capacity for these situations, and constant exhaust operation during cooking periods is always recommended for the hypersensitive. The most important considerations for rigorous kitchen air quality are:*

- *Electric cooking appliances only. Any use of natural gas, propane or any open flame is not recommended.*
- *Ceramic or glass top cookers are preferred for their ease of cleaning.*
- *Direct vented ovens are preferred. These are typically only available as wall ovens.*
- *A hood-type exhaust unit is preferred to a downdraft unit. The hood should be as low*

*as is practical over the cooking surfaces, and should extend beyond the range by at least 150 mm on each side if possible.*

- *A work surface for small appliances, also under the hood, is recommended.*
- *A remote-mounted exhaust blower with a variable speed control is recommended because it is the quietest type.*
- *Maximum exhaust capacity will typically exceed 200 L/S (425 cfm).*
- *Addition of incombustible (i.e., stainless steel) side baffles extending from the hood to the range surface can significantly aid exhaust effectiveness, but these are inconvenient.*

*Installation of large-capacity kitchen exhausts must consider their possible effects on other systems in a draft-sealed house. They are not compatible with conventional fireplaces or naturally aspirated, naturally vented furnaces, water heaters or boilers. In these circumstances, it may be necessary to provide make-up air (i.e., a supply of outside air to replace the air removed by the exhaust when it is on high speed). Make-up air may need to be preheated to prevent comfort complaints. This requires a design by a qualified ventilation expert.*

*Non-ducted kitchen range hoods are not an acceptable substitute for a kitchen exhaust. These units recirculate kitchen air through a charcoal filter; but do not exhaust odours, pollutants and hazardous gases. The charcoal filters become loaded with odours very quickly.*

### **Central Exhaust Ventilator**

A central exhaust ventilator (CEV) is a single exhaust fan mounted in a box which typically draws air from bathrooms, kitchen and laundry and discharges it through a single duct (Figure 33). A CEV generally has from 60 to 150 L/S capacity (128 to 318 cfm) and can be installed in attic spaces, under stairs or, occasionally, basements or crawlspaces. A relatively

inexpensive exhaust-only system option, a CEV is quiet and reliable. The ducting requirements are simple and the units are available packaged as a system, ready to install. It has the same limitations as all exhaust-only systems in that supply air cannot be reliably controlled.

A variant of the central exhaust ventilator is the heat pump exhaust system sometimes used in Canadian houses. Heat pump systems extract heat from exhaust air which is then used to heat domestic hot water.

### **Duct types and sizing**

Some units are equipped with flexible ducts which can be extended, if necessary, by connecting them to rigid sheet metal ducts. Room exhaust duct size is usually 100 mm to 150 mm (4 in. to 6 in.) and main building exhaust 150 mm to 200 mm (6 in. to 8 in.). Total flexible duct length should be minimized and kinks and bends avoided as much as possible.

### **Duct installation**

Condensation can form in ducts exposed to cold air. For this reason, ductwork should be kept inside the heated envelope where possible. If there is a risk of condensation formation, the fan unit should be mounted at a high point and the main exhaust duct sloped downward to the exit point. Furthermore, by running the fan continuously (on low speed), the risk of condensation is reduced.

### **Supply air options**

CEVs can be integrated with forced air heating/cooling systems the same way that other exhaust-only systems can. See the supply air discussion at the beginning of this section.

### **Capital cost**

A packaged CEV unit can be installed in a modest-sized new home for about \$500 to \$1,000. Passive through-wall slots will add approximately \$40 to \$60 per room.

**Figure 33:**  
**Central Exhaust Ventilation System**

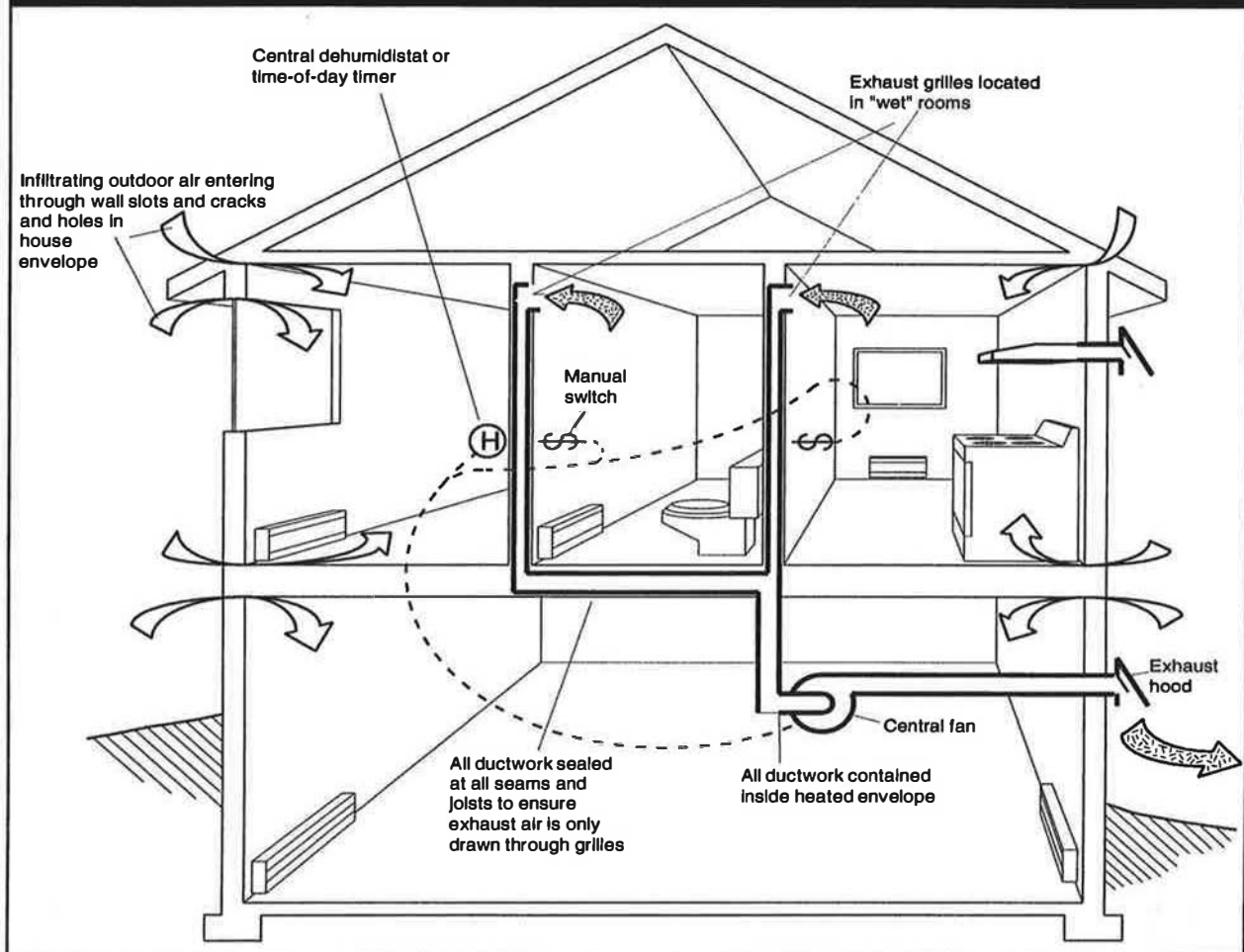

**Operating costs**

Continuous exhaust-based systems without heat recovery are more costly to operate than heat recovery ventilation systems due to increased heating and cooling requirements.

**Maintenance**

CEV units require occasional fan and duct cleaning and system checks similar to other exhaust units.

**Applications for the environmentally hypersensitive**

*The central exhaust system has no special merits for the hypersensitive over other exhaust-only*

*ventilation systems. Due to the inability of exhaust-only systems to provide reliable supply air, they are generally not preferred. They cannot provide filtration of supply air and they tend to draw air in through building cavities introducing dust, pollens and pollutants from insulation and other materials.*

**Demand-Controlled CEV System**

**General Description**

An exhaust-only system with exhaust grilles and through-wall supply slots which are regulated by indoor humidity is now available. Both the exhaust rate from the bathrooms and kitchen and the supply rate into bedrooms and living rooms is varied automatically by a passive,

humidity-sensitive regulator. The exhaust blower is the only electrical device in the system.

**Humidity-actuated exhaust grill**

Exhaust grilles are installed in wet rooms and are ducted to the exhaust fan. Increased humidity in the room causes the regulator to open, extracting more air. A wall-mounted pneumatic button allows selection of full exhaust capacity on demand (Figure 34).

**Humidity-actuated through-wall supply grille**

Narrow supply slots located near the ceiling in bedrooms and living areas also contain a humidity-sensitive regulator which opens them when humidity rises. Incoming air mixes with room air near the ceiling reducing discomfort complaints (Figure 35).

**Fan requirements**

The system uses a fan, selected to ensure airflow at a predictable rate through the restrictions of the humidity-controlled regulators. The fan usually operates continuously, or can be controlled by dehumidistat or other sensor.

**Typical applications**

This system has similar properties to the conventional CEV system described above, with the additional merit of better exhaust flow control and, therefore, improved energy efficiency. The intake supply slots also have the advantage of flow control which the fixed passive slots do not have. However, exhaust-based systems

**Figure 34:**  
**Humidity-Actuated Exhaust Grille**

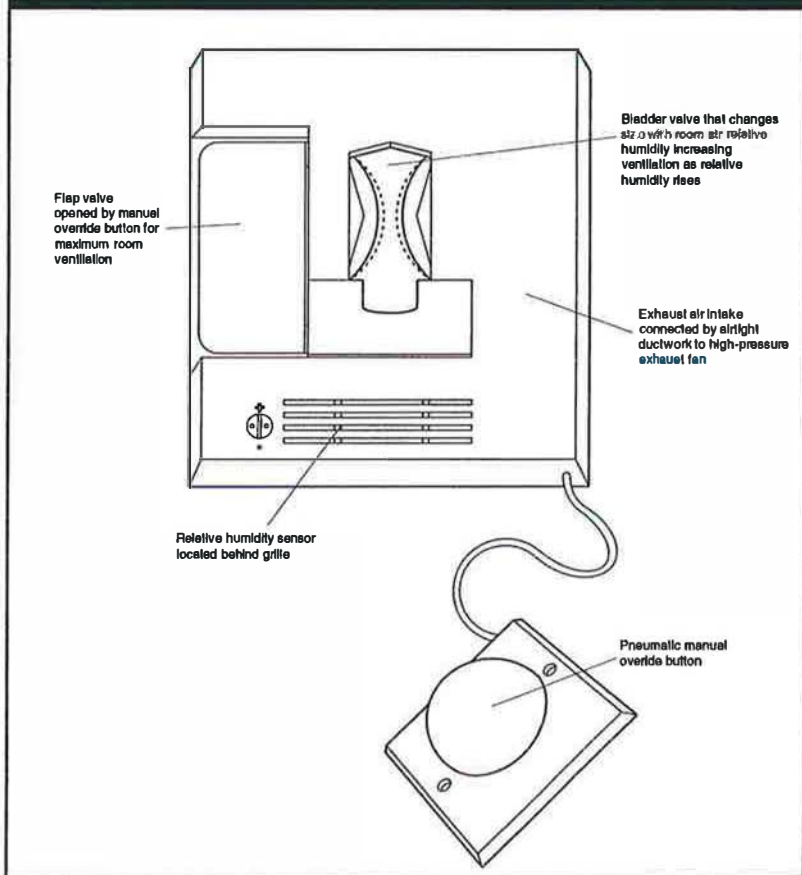

**Figure 35:**  
**Humidity-Actuated Through Wall Supply**

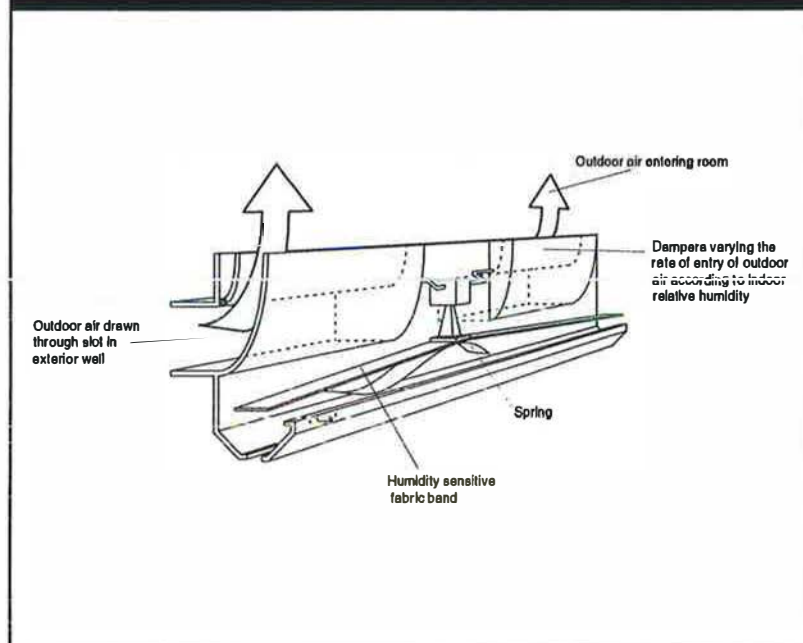

with passive air supply slots are not recommended for retrofits to older houses. The building envelope must be well draft sealed for the system to function. These systems can be particularly useful for newer, tight, electrically heated homes.

### **Integration with forced air heating**

Similar to other exhaust-based systems, an outside air supply to the return side of a furnace/air conditioner can provide a supply air path. In this case, the humidity-controlled intake slots are not used.

### **Applications for the environmentally hypersensitive**

*An exhaust system with air-inlet devices in all occupied rooms is only likely to be acceptable in locations with very good outdoor air quality and warmer climates, because the intake cannot be effectively filtered. Furthermore, because this system produces a continuous negative pressure, the building envelope must be sealed for drafts. Negative pressure encourages infiltration of air through insulation materials and entry of dust from building cavities. Negative pressure may also cause the entry of soil gases (methane and radon) and the back venting of fireplaces and other naturally aspirated combustion devices.*

### **Recirculating Central Ventilation Systems (RCVs)**

A recirculating central ventilator (RCV) is essentially a single fan contained in an insulated box. The fan picks up a volume of air from the house ranging from 50 to 100 L/S (106 to 212 cfm), exhausts part of it to the outdoors and mixes it with approximately 20 per cent outdoor air. The RCV then delivers this mixture of recirculated and outside air back to the space through a supply duct system. The outdoor air tends to be warmed by mixing with recirculated air. Some RCVs exhaust a similar quantity of air as is brought in from outside so the ventilation is balanced (Figure 36). Speed controls are available that allow for continuous low-speed operation with periodic high-speed operation when called

for by a humidity sensor or manual switch. Some RCVs also control the outdoor air quantity from zero to maximum, based on humidity. Most RCVs provide built-in filters for both outside and recirculated air. Some allow installation of higher-performance filters.

RCVs are limited in the quantity of outdoor air that can be supplied because they depend on mixing with recirculated air to warm the incoming air. Total ventilation is usually limited to about 10 to 20 L/S (21 to 42 cfm). Higher outdoor air rates would result in discomfort and condensation on ducts and metal housings.

### **Size and location**

RCVs are rectangular boxes about 30 cm to 40 cm (12 in. to 16 in.) in size. They are designed to be installed in attic and basement locations. Basements are preferred due to improved access for service and lower energy loss in a heated space. However, in many situations, attic installation is the only practical option.

### **Exhaust and supply grille location**

There is no convention for the location of exhaust and supply grilles for RCVs. In the simplest installations, one supply and one exhaust grille are located as far apart as possible in the house. More precise selection of the supply and exhaust grille locations will depend largely on the objectives of the installation. If the installation is strictly for humidity control, then exhaust inlets may be located in the wet rooms (baths, kitchen and laundry) with supply ducts in remote areas such as the basement and utility rooms. Unfortunately, this approach will lead to the distribution of odours around the home. One approach is to provide general ventilation and air supply with the RCV and spot ventilate as necessary with separate bath and kitchen fans. In this case, the supply and return ducts may be located in the bedrooms and living areas.

RCVs are particularly successful when used to ventilate a single area such as a bedroom or group of bedrooms. In this situation, the rooms will be

Figure 36:  
Recirculating Central Ventilation System

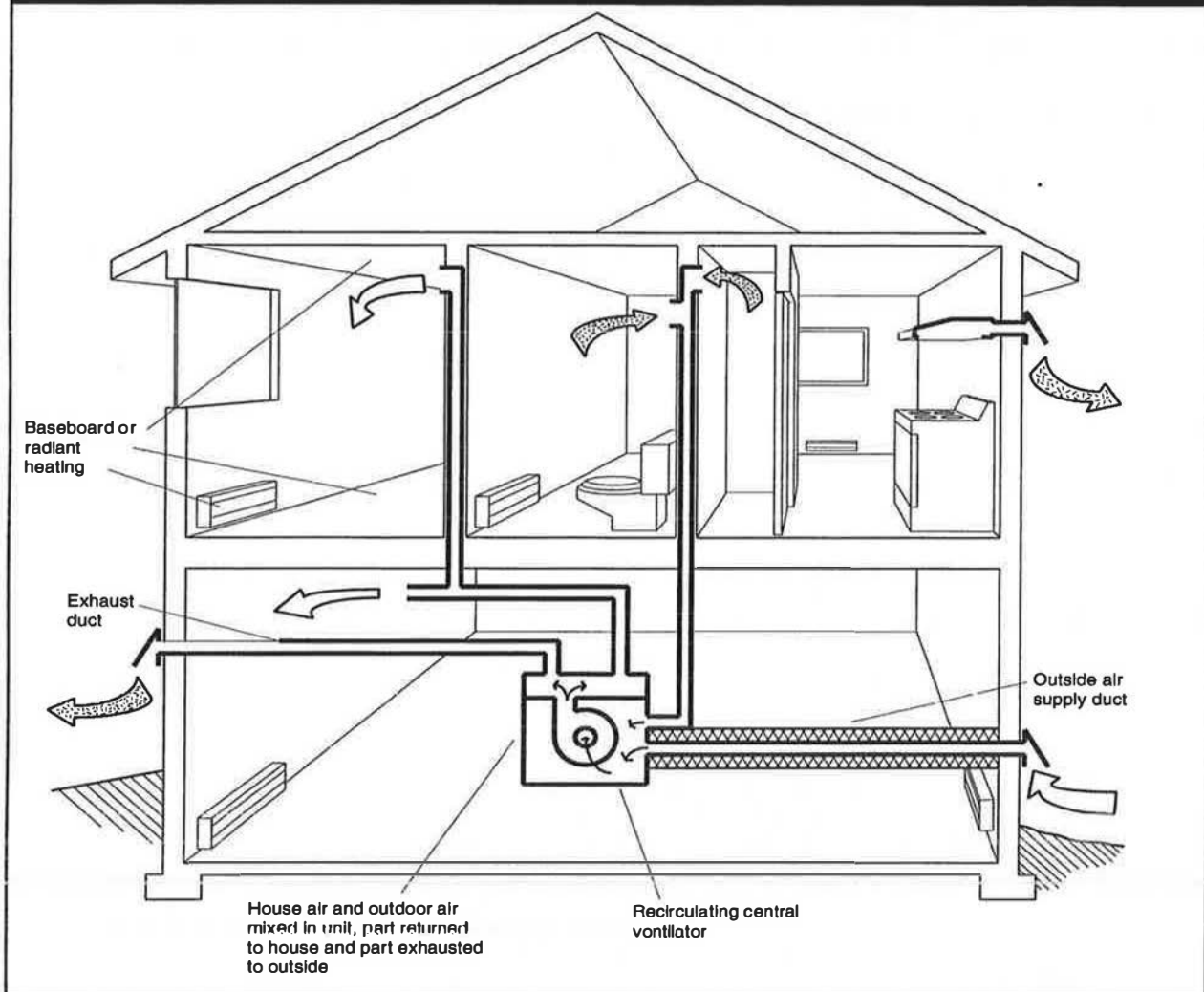

well ventilated and good air mixing and some filtration can be provided. This approach can be used in houses equipped with a forced air system where it is preferred that the forced air system not operate continuously because of cost or to avoid distribution of contaminants from other areas of the house.

RCVs may also be successfully used as part of a whole-house distribution strategy where air is to be moved from a primary occupied area, such as a bedroom, to a secondary area, such as a living area, or from a living area to a remote zone, such as washroom, basement or exhaust closet. In these situations, the RCV operates together with other exhaust fans or with another ventilation system.

RCVs do not have the same air quality and energy conservation benefits as HRVs. Because approximately 80 per cent of the air is recirculated, air contaminants picked up by the exhaust will be immediately distributed to the supply location when the ventilator is operating.

#### Exterior hoods, ducts and duct sizing

The location and selection of intake and exhaust hoods is very important for controlling the quality of supply air. Intakes can be easily contaminated by auto exhaust, combustion gases, sewer and garbage odours, and gas and oil services. Ducts must be sized carefully and insulated in most



Canadian climates. See heat recovery ventilators in this chapter for a more detailed discussion.

### **Integration with forced air heating systems**

RCVs are generally not integrated with forced air heating systems. A forced air system is easily modified to function like an RCV simply by adding an outdoor air duct connected to the return air plenum.

### **Typical applications**

RCVs can be cost-effective, simple solutions for some circumstances. However, they are limited in their total ventilation capacity and it is difficult, or impossible, for the installer to determine the quantity of outdoor air being supplied.

Some people may be misled into thinking that an RCV can provide the full ventilation requirement for a home. In practice, RCVs may actually aggravate air quality problems by distributing unwanted contaminants from one area of the house to another. One example is soil gas and microbiological contaminants that may be distributed from a basement area to a sleeping area. RCVs are best limited to use as either a single-room ventilation device or a recirculation device between rooms.

### **Capital cost**

An RCV is more expensive than a simple exhaust-only or recirculation fan system, but cheaper than an HRV system. Units are typically under \$500 and an installed system may cost around \$850. However, the initial price difference between an RCV and a small HRV is very little when the quantity and quality of ventilation and operating costs are considered.

### **Operating costs**

An RCV costs more to operate than an HRV providing an equivalent ventilation rate due to its inability to recover heat lost with the exhaust air. However, it costs less to operate than a central forced air furnace with an outdoor air supply,

since fans are typically smaller than furnace supply fans.

### **Maintenance**

Semi-annual inspection and cleaning of outdoor hoods, the fan and filters are recommended. Annual lubrication and inspection of the fan motor are recommended, though many motors have sealed bearings requiring no lubrication. Access for maintenance may be difficult if the unit is located in an attic.

### **Applications for the environmentally hypersensitive**

*Unless the unit is being used to ventilate a single room or group of rooms (such as a bedroom or group of bedrooms), or the unit is being used as a distribution device together with another ventilation system, there is little to recommend this equipment, other than low capital cost.*

### **Balanced Ventilation Systems (Heat Recovery Ventilators)**

A balanced ventilation system provides a fresh air supply and stale-air exhaust at equal rates by moving both the exhaust air and supply air with fans (Figure 37). This type of system typically uses a heat recovery ventilator (HRV). Balanced systems eliminate most of the problems encountered with supply-only and exhaust-only systems, although they generally cost more. They contain one or two fans and a heat-exchange core. One of the fans extracts stale air from the house passing it through the heat exchange core, while the other fan brings in outside air through the heat-exchange core. The two airstreams do not come into direct contact in the core, but the incoming airstream is warmed by the heat lost from the outgoing airstream (Figure 38).

HRVs produce condensation on the heat exchange core during cold weather as warm exhaust air contacts the cold surfaces. The condensate is collected by a drip pan and carried to a drain. (In colder weather, it may freeze causing frost buildup in the core.) Most HRVs sold in Canada

Figure 37:  
Balanced Ventilation System

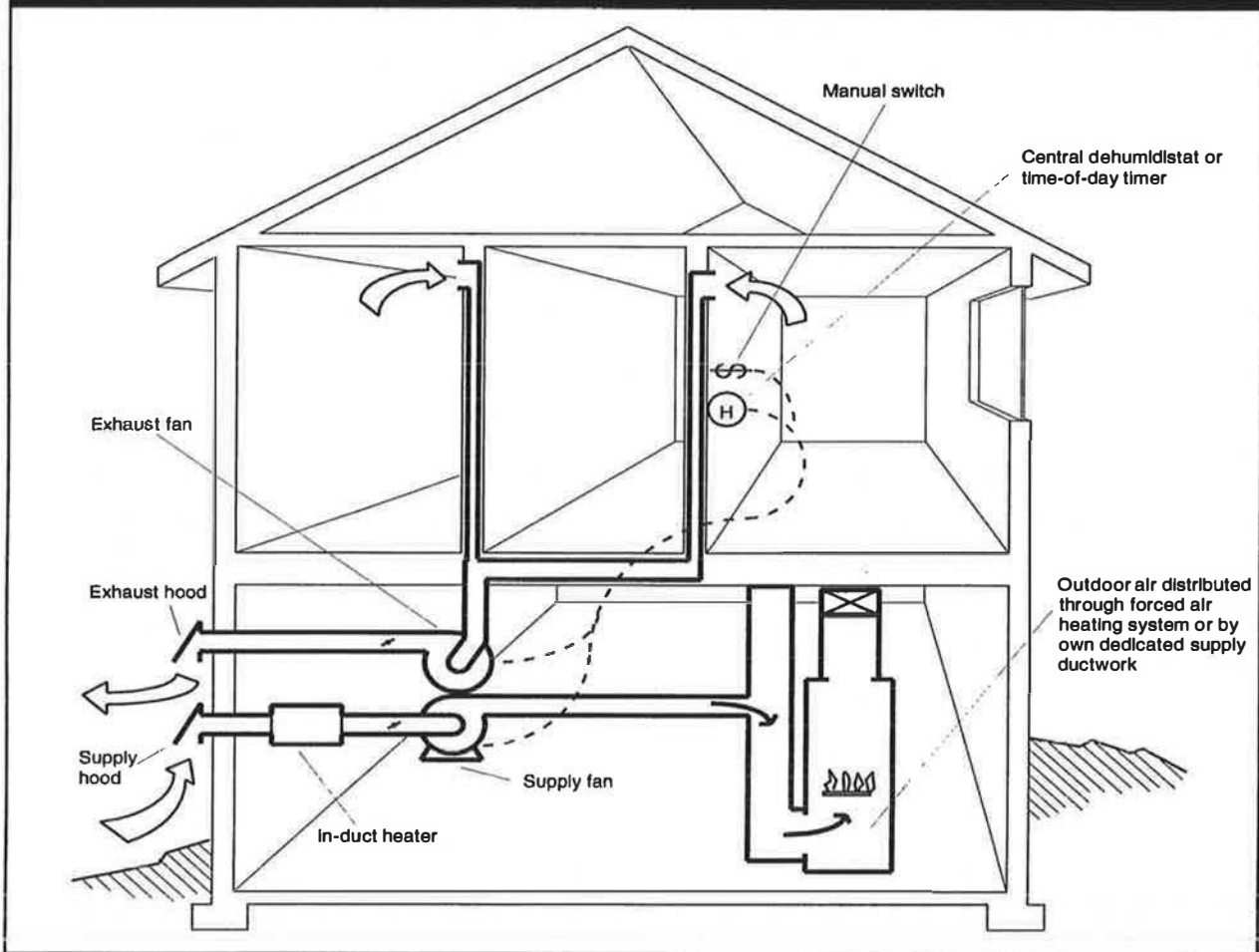

are equipped with an automatic defrost system which ensures that the frost in cold weather is periodically removed from the core so the equipment continues to ventilate. Like air conditioners and heat pumps, maintaining the condensate drainage system is very important for preventing health hazards. See the equipment reports for more details about defrost methods.

HRVs are usually equipped with very basic filters for both the incoming and the outgoing air. Most models are also able to accept higher performance filters and can have more sophisticated air cleaner arrangements added for maximum treatment of incoming air. See Chapter 6 for more details.

HRVs range in cabinet size from 45 cm x 60 cm x 60 cm (18 in. x 24 in. x 24 in.) up to 150 cm

(60 in.) long and 120 cm (48 in.) tall. Most common residential units are on the compact side, whereas higher-capacity, higher-efficiency units tend to be larger. HRVs must be installed inside the heated space of the building, usually suspended from the ceiling. They are commonly located in the basement or in a utility room or closet. Duct connections and maintenance access may require significant space.

The Home Ventilation Institute (HVI) publishes a catalogue of test results for HRVs. HVI performance-certified units will carry a blue foil label with the HVI logo. Residential HRVs typically have a capacity between 50 and 125 L/S (106 and 265 cfm) on high speed, and a low-speed capacity of about one half of the high-speed capacity. These capacities match quite closely the

Figure 38:  
Heat Recovery Ventilator

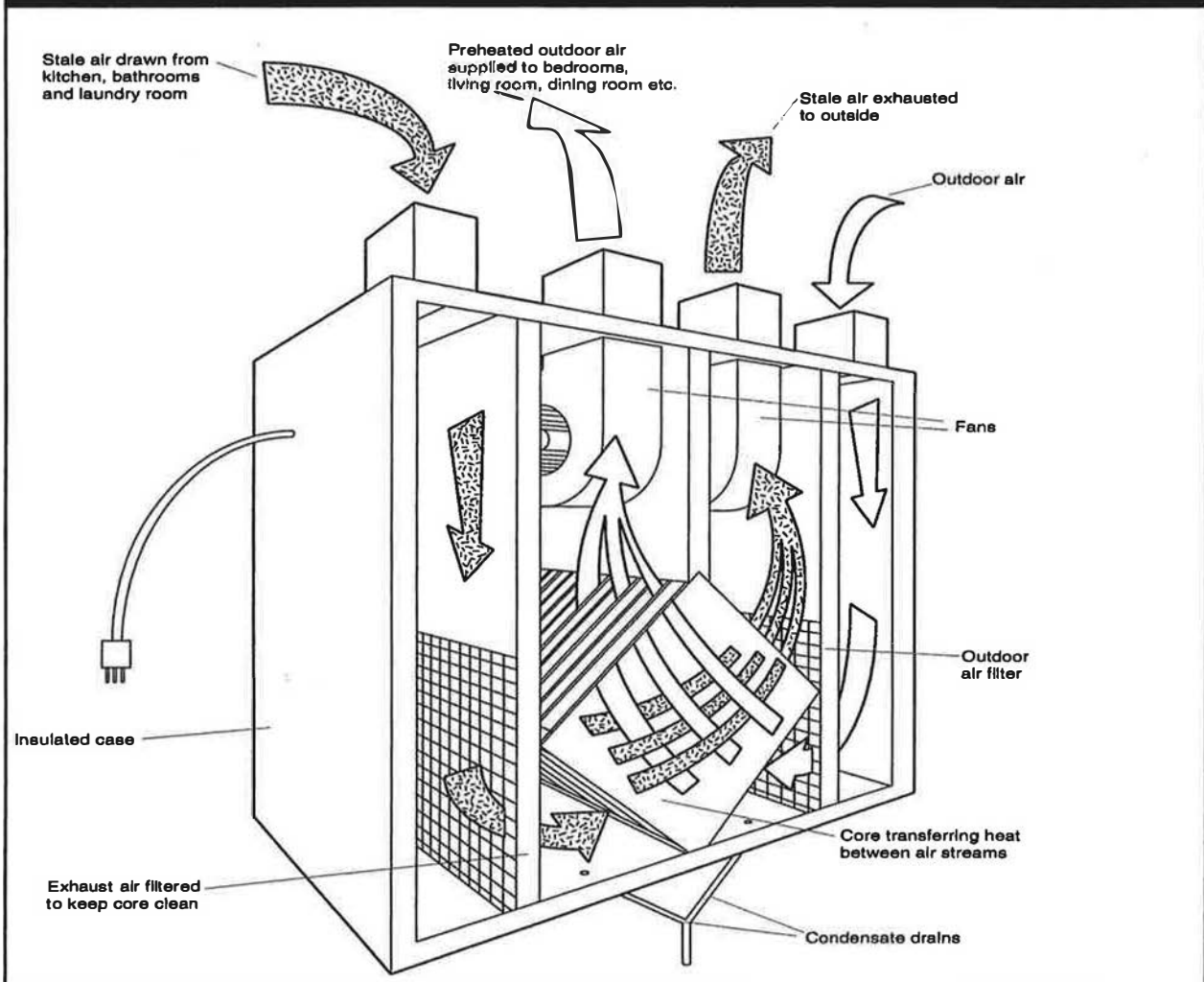

range of recommended ventilation capacities for a typical home calculated on the minimum 5 L/S (10 cfm) per room. Heat recovery efficiency is normally tested at 0°C and -25°C (32°F and -13 °F) and ranges from about 55 to 80 per cent under different conditions. When comparing ventilation capacity or heat recovery efficiency between units, be sure the test method is the same.

### Controls

HRVs typically contain an internal fan speed control system, on/off switching and a defrost control. It is recommended that they be run continuously on low speed, with high-speed

operation controlled by a dehumidistat or timer. Some units are equipped with a built-in dehumidistat and a remote control system for high-speed operation on demand. These units respond to push button controls, usually located in bathrooms, by switching to high speed for 10 to 20 minutes. One unique control device for HRVs uses an electronically operated exhaust grille which opens fully when a wall button is pressed. This diverts most of the exhaust capacity of the HRV to one location for 10 or 20 minutes.

### Exhaust and supply grilles (Interior)

Exhaust grilles are directly ducted to the HRV and are normally located in the bathrooms,

laundry and kitchen, as close as possible to the contamination source. This way, the most humid and contaminated air is exhausted. In some specially built houses, there are also exhausts located in closets which help to prevent odours from stored clothing and materials from entering the house. In all cases, where only an exhaust or supply grille is located in an enclosed room, the door must either have louvers allowing air to pass through or it must be undercut to clear the finished floor by at least 12 mm (1/2 in.). HRV exhausts located in kitchens are not a substitute for a range exhaust and should be located at least 1.2 m (48 in.) away (horizontally) from a cook top. See the information on kitchen range exhausts in this chapter.

In a forced air system, the supply from the HRV is typically connected to the return air plenum of the heating system. In this arrangement, the heating fan and ducts are used to circulate supply

air (Figure 10). This requires that the furnace fan run continuously. If the forced air heating ducts are not used to distribute the supply air from the HRV (because this can cause occupant discomfort when the furnace burner is off), then a separately ducted supply system must be used for each occupied room. These are usually ceiling grilles or high wall grilles in the bedrooms, family room, library, dining room and any other rooms which are usually occupied (Figure 39).

When locating supply grilles in a room, the path of air travel in the room should be considered. The ideal air path is to sweep the room from one end to another, so if the air exit point is under the door or through a closet then the supply location should be as far from this point as possible. See the discussion of ventilation effectiveness and distribution at the beginning of this chapter (Figure 27).

Figure 39:  
Central Heat Recovery Ventilator for Use with Baseboard or Radiant Heating

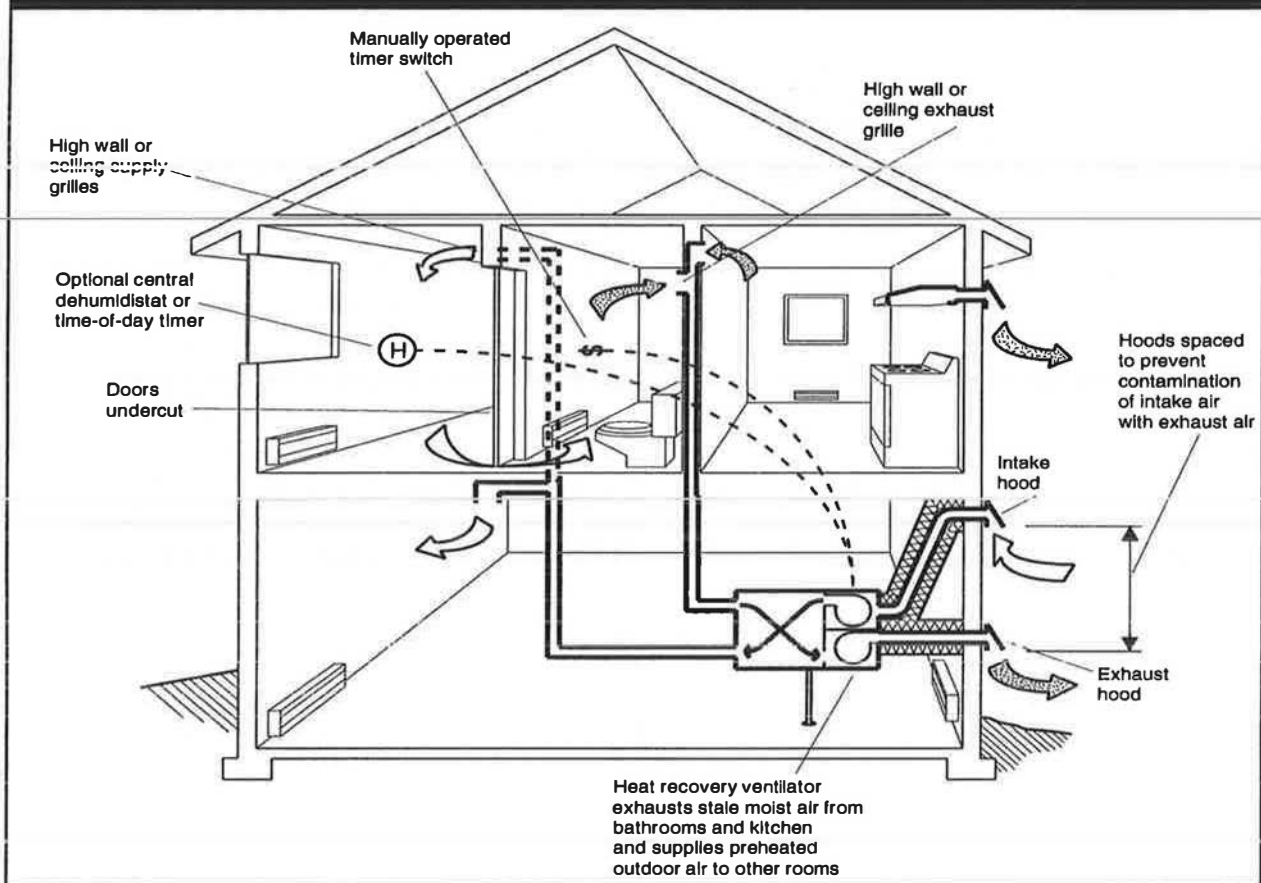

A small HRV can also be used to ventilate a single bedroom or group of rooms. The HRV is connected directly to the rooms and exhaust air may be removed from the closet or an adjoining bathroom. In this way, the space may be ventilated independently from the rest of the house, without depending on the operation of a central system. Some small HRV units are available for this purpose, including wall-mounted units which have very simple ducting arrangements.

#### **Air Intake and exhaust (exterior)**

HRV intake hoods provide the outside air supply for the home and should be carefully placed in order to obtain the highest-quality air possible. Though only 45 cm (18 in.) clearance above grade is usually recommended, much higher locations are advisable to reduce the risk of entry of debris, automobile exhaust, garden chemicals and other contaminants. The intake must be above the snow line. Locations adjacent to chimneys and plumbing vents, as well as kitchen and bath exhaust discharges should also be avoided. Intakes should always be equipped with a screen to prevent rodents, birds and insects from entering. As a general rule, HRV intake hoods should be at least 2 m (6.5 ft.) upwind of the nearest pollution source.

Some of the local sources of contamination of HRV intakes are:

- driveways;
- barbecues;
- gas meters;
- oil fillers;
- garbage storage areas;
- pet areas;
- dryer exhausts;
- chimneys or gas vents; and
- asphalt roofing.

When it is difficult to bring the HRV intake through the wall at an ideal location, it can be brought through elsewhere and connected to an uninsulated duct on the outside of the house in order to reach a location where better quality air may be obtained. These intake location

considerations apply equally to any building air intake such as an outdoor air connection to a forced air heating system. Because the screen in the air intake hood can become blocked by leaves and debris, the hoods must be accessible for cleaning.

Exhaust hoods may be located at practically any location; however, it is best to be at least 1 m (40 in.) from a building opening. If located high up, it should be in a location where it may be inspected and cleaned, if necessary. An HRV or exhaust fan should never be exhausted into an attic, garage, crawlspace or other enclosed space. Exhaust hoods should also be equipped with a backdraft damper, and rodent, insect and bird screen.

#### **Ducts**

Both the intake duct from the outdoors and the exhaust duct leading to the outside should be insulated to prevent condensation, especially where they run through heated spaces. At least 25 mm (1 in.) thick insulation with a vapour barrier jacket should be used. Often, this is provided by using vertically slit lengths of pre-insulated flexible ducting, used as a jacket over the duct. If the intake duct runs for more than about 3 m (10 ft.) through a conditioned space, consideration should be given to increasing the amount of insulation used as an energy measure.

When any exhaust or supply air ducts from the HRV to the rooms are installed in an unheated space such as an attic, the duct must also be insulated: 50 mm (2 in.) insulation is usually recommended. The duct should be made as airtight as possible by taping or sealing all connections, joints and seams. When these ducts are installed in an insulated attic, they should be run on the underside of the attic insulation if possible.

The ventilation designer or contractor will normally select the appropriate size of duct to use for each situation. In general, exhaust and intake ducts and main supply and return ducts will be 150 mm or 175 mm (6 in. or 7 in.) in diameter.

Branch ducts serving one diffuser may be as small as 75 mm or 100 mm (3 in. or 4 in.). The use of flex duct should be limited both for air quality and flow-resistance reasons. Short pieces used for vibration isolation and passing through difficult frame areas are usually acceptable.

The Heating, Refrigerating and Air Conditioning Institute of Canada (HRAI) offers certification courses for contractors in ventilation and HRV installation based on the national ventilation standard CSA F326. Contractors who have taken this program and are listed as certified ventilation system installers or designers are capable of designing a ductwork system for most residential applications. This training should not be confused with training provided by local HRAI chapters for provincial building code compliance. HRAI-certified contractors must enter into an arbitration/decertification agreement to provide assurance of a properly designed and installed ventilation systems.

#### **Integration with forced air heating systems**

HRVs are commonly integrated with forced air heating systems in simplified and hybrid arrangements, since supply ductwork does double duty. The hybrid arrangement is economical especially if a forced air system exists.

If the primary forced air system fan is not necessarily intended to be operated continuously, if it does not serve the entire house or if the house is intended to be zoned separately and kept isolated for air quality reasons, then it may be necessary to consider installing an independent HRV-based ventilation system, even if a forced air system exists. The system will require both supply and exhaust ducts throughout the ventilated zone. An independent system has merit because ventilation can be controlled separately from heating and cooling, although initially it costs more.

#### **Capital cost**

HRVs are more expensive than exhaust-only or recirculation ventilation systems. Small-capacity

HRVs installed as simple systems may cost \$1,500 to \$2,000. Systems with more complex ducting and large-capacity, high-performance HRVs may cost more than \$3,000.

#### **Operating costs**

Ventilation costs vary with climate, building design and heating system design. However, on the basis of amount of ventilation provided, an HRV will provide the lowest operating cost when compared to all other systems. An HRV-system can also be installed independently of the heating system so it can be operated continuously without heating fan operation. This will reduce electrical costs when heating or cooling is not in use.

#### **Maintenance**

Occasional inspection and cleaning of outdoor exhaust and inlet hoods, and cleaning of unit and filters is recommended. Fungal contamination of the air can result from dirty filters within the HRV. Cleaning the filters should be done regularly. Annual lubrication of the fan motor is recommended, though many motors have sealed bearings requiring no lubrication.

#### **Applications for the environmentally hypersensitive**

*An HRV is often the basis for ventilation in housing where exceptional air quality is required. There are, however, several special considerations which should be remembered.*

- *High ventilation rates will lead to dryness in winter. Humidification may be required in many Canadian climates.*
- *High-performance filtration, including gas scrubbers to remove odours from outdoor air, can be added to the HRV supply duct if necessary. In some cases, these will require a separate filter housing. These gas scrubbers may not be adequate if the outdoor pollution is high. In these situations, it is best to turn the HRV off temporarily.*

- A small HRV can be used to serve a single room, or a group of rooms, if these rooms can be adequately isolated from the remainder of the house.
- HRVs with plastic cores may not be acceptable to the hypersensitive. Aged plastic cores which have been stored in a heated chamber to reduce odours, or odour-free metal cores are available for some units. (Stainless steel cores are quite expensive). Enthalpy type HRVs use a core with resin paper. The environmentally hypersensitive should test the core first for tolerability. Aluminum cores are available and should be tested for acceptability.
- All components of the system should be carefully selected to avoid soft plastics, oily residues, rubber seals and gaskets, plastic tape, caulking and liquid sealants.
- A unit which does not expose motor windings to the airstream is preferred because it requires no lubrication oil.

*Special models incorporating many of the above features are not available commercially and can be obtained by custom modification of commercial units by competent contractors.*

### **Air-Inlet Devices**

- Hard plastic or metal units.
- Some have manual control by pull cord.
- Some limited air filtration ability.

### **Other common names**

- Passive vents;
- passive slot diffusers; and
- high-wall diffusers.

### **Typical system applications**

- Introduce and distribute outdoor ventilation air directly into room. Used with controlled exhaust systems.
- Usually used in bedrooms and living rooms.

### **Installation considerations and options**

- Must be carefully located to avoid cold drafts. High wall location near ceiling preferred.
- Should be as far as possible from exhaust point in room.
- A unique unit provides airflow control based on indoor relative humidity.

### **Health issues**

#### *Advantages*

- Can provide cleaner supply air (than by infiltration) for exhaust-only systems.

#### *Disadvantages*

- No filtration possible, not appropriate for polluted regions.

### **General comments**

Not acceptable in very cold climates.

### **Maintenance requirements**

Periodic cleaning; the filters are usually washable.

### **Product sources**

Specialty ventilation suppliers.

See also the information on control exhaust systems and exhaust fans in this chapter.

## Central Exhaust Ventilator

This type of fan is installed in a box with several exhaust ducts, connected to humid rooms and with an outside discharge.

### Other common names

- Ducted, whole-house fan; and
- CEV.

### Typical system applications

For bathroom, kitchen and laundry exhaust with any type of heating system.

### Installation considerations and options

- Unit may be located in attic or basement. Flexduct connections are often provided with unit.
- Unique system with humidity-controlled air inlets and exhaust is available.
- Exhaust duct must be sloped down to the discharge point.

### Health Issues

#### *Advantages*

- Generally, provides adequate continuous exhaust for moisture control.
- Quiet reliable operation.

#### *Disadvantages*

- Controlled supply air must be provided separately.

### General comments

May be controlled by dehumidistat or timer.

### Maintenance requirements

Occasional checks and cleaning.

### Operating cost/savings

Fan operation is inexpensive. Ventilation cost depends on heating system and other ventilation factors.

### Product sources

- Heating and ventilation contractors; and
- equipment manufacturers.

See also the information on ventilation accessories and air-inlet devices in this chapter.

## Duct Fans

- Compact centrifugal fans mounted in round sheet metal duct or rectangular boxes.
- Generally high-quality motors, quiet and efficient (varies with model).
- Can operate at high static pressure and continuously.

### Other common names

- In-line fan; and
- cabinet fan.

### Typical system applications

As remote-mounted exhaust fans, booster fans for heating and ventilating and radon control fans.

### Installation considerations and options

- Commonly available in 125 mm to 250 mm (5 in. to 10 in.) duct sizes.
- Common capabilities of approximately 25 to 200 L/S (53 to 424 cfm).
- Check noise rating before purchasing.



## Health issues

### Advantages

- Preferred for quiet continuous exhaust systems.
- Useful for operating custom air filtration systems and for ducted exhausts where quiet, remote mounted blower is required.

### Disadvantages

- Ideal for mounting in ducts serving sub-slab radon control systems.
- Usually have totally enclosed motors with sealed bearings.

### Maintenance requirements

Minimal.

### Operating cost/savings

Moderately efficient, split-capacitor motors.

### Product sources

- Heating and ventilation contractors; and
- specialty ventilation suppliers

See also the information on air-inlet devices in this chapter and the text on air filtration in Chapter 6.

## Ducts, Flexible Duct and Sealers, Duct Insulation

- Light gauge galvanized sheet metal, or paintable, anodized steel ducts (satin finish).
- Metal foil duct tape (or liquid latex seal if acceptable to the hypersensitive).
- Metal foil, mylar (polyester) or extruded aluminium coil flexible duct.
- Spun fibreglass insulation.

## Typical system applications

- Supply and exhaust ducts for ventilation systems.
- Sealer for duct joints.
- Vibration isolating duct connections.

## Installation considerations and options

- Sheet metal ducts are preferred.
- Sheet metal carries oily residues. Ducts may be washed with mild detergent or washing soda solution (sodium carbonate), rinse after.
- Satin-galvanized steel, aluminum or “galvalume” steel ducts may have less oily residue.

## Health issues

### Advantages

- Sheet metal duct provides cleaner supply air and is more easily cleaned.
- Metal foil tape is generally less odorous than fabric tape or liquid duct sealers.
- Anodized steel, aluminum or “galvalume” duct may have less oily residues.
- Insulated and sealed ducts resist condensation and contamination.

### Disadvantages

- *Vinyl fittings and covering should be avoided by the hypersensitive.*
- Flexible ducts trap contaminants, offer greater resistance to airflow and can contribute emissions to the air.
- Insulation should be tightly covered with foil to resist fibre shedding.

### General comments

Flexduct is more acceptable for exhaust stream.

### Maintenance requirements

Periodic inspection, especially of seals and flexible parts.

### Product sources

Sheet metal contractors.

### Exhaust Fans

These small propeller fans or centrifugal blowers (in better quality units) are for ceiling or wall mounting. They are usually ducted to a hood or register with a backdraft damper at the outlet.

### Other common names

- Low-sones bath fans; and
- bathroom fans.

### Typical system applications

Moisture, pollutant and odour removal from baths, laundry and kitchen.

### Installation considerations and options

- Short duct runs with smooth duct, minimum bends and adequate duct size are essential for effectiveness.
- Better-quality units are quieter (2.5 sones or less).
- Reversible and speed-controlled units are available.
- Wall-mounted units with automatic shutters are available.

### Health issues

#### Advantages

- Effective means of discharging air pollutants at source.
- Effective for moisture and local odour control.
- May be used for local exhaust in any system if safe house depressurization limits are not exceeded.

#### Disadvantages

- Supply air is not controlled in exhaust-only systems.

### General comments

Low noise fans are also better quality and are more durable.

### Maintenance requirements

Occasional cleaning.

### Operating cost/savings

Depend on heating system and other ventilation factors.

### Product sources

- Heating and ventilation contractors;
- building suppliers; and
- electrical contractors.

See also the information on vent accessories and air-inlet devices in this chapter.

### Heat Recovery Ventilators

Heat recovery ventilators are usually classified by the type of heat transfer core they use. The three types commonly used are:

- plate cores;
- rotary wheel cores; and
- heat pipe cores.

### Plate cores

Plate cores consist of thin, parallel plates of plastic, metal or special paper that separate the exhaust and supply airstreams (Figure 40). The plates are so thin that heat easily transfers from one airstream to the other. Low-odour metal cores and specially aged, low-odour plastic cores are available from some manufacturers for use where rigorous air quality control is a priority.

During the winter, moist exhaust air loses its heat to the incoming air as it passes through the core, causing condensation. The condensate is collected in a drain pan inside the HRV and drained to a floor drain. Plate core HRVs are typically 70 to 80 per cent efficient at transferring heat, depending on the core configuration. This type of HRV does not transfer moisture between airstreams. For this reason, they tend to dry the home during the heating season and are not capable of dehumidifying humid supply air during the cooling season.

### Rotary wheel cores

In rotary core HRVs, a perforated plastic or metal wheel rotates continuously between the exhaust and supply airstreams, transferring heat and moisture between the two (Figure 41). These units do not dry the house as much as plate-type units do in winter because they transfer a large percentage of the moisture from the exhaust airstream to the supply airstream. This same characteristic allows them to dehumidify air entering an air-conditioned building in the summer. Due to the moisture return in these units, no condensate drain is required. These types of units have heat recovery efficiencies in the 80 per cent range. Some manufacturers make desiccant-coated wheels as an option for better moisture transfer ability.

### Heat pipe cores

Heat pipe cores consist of a set of heat pipes that contain a refrigerant liquid that boils at a low temperature. The lower end of the heat pipes is heated by the exhaust air, causing the liquid to boil. The liquid vapours then rise to the upper end of the heat pipe where they condense and release heat into the supply airstream. These

Figure 40:  
Plate Type HRV Cores

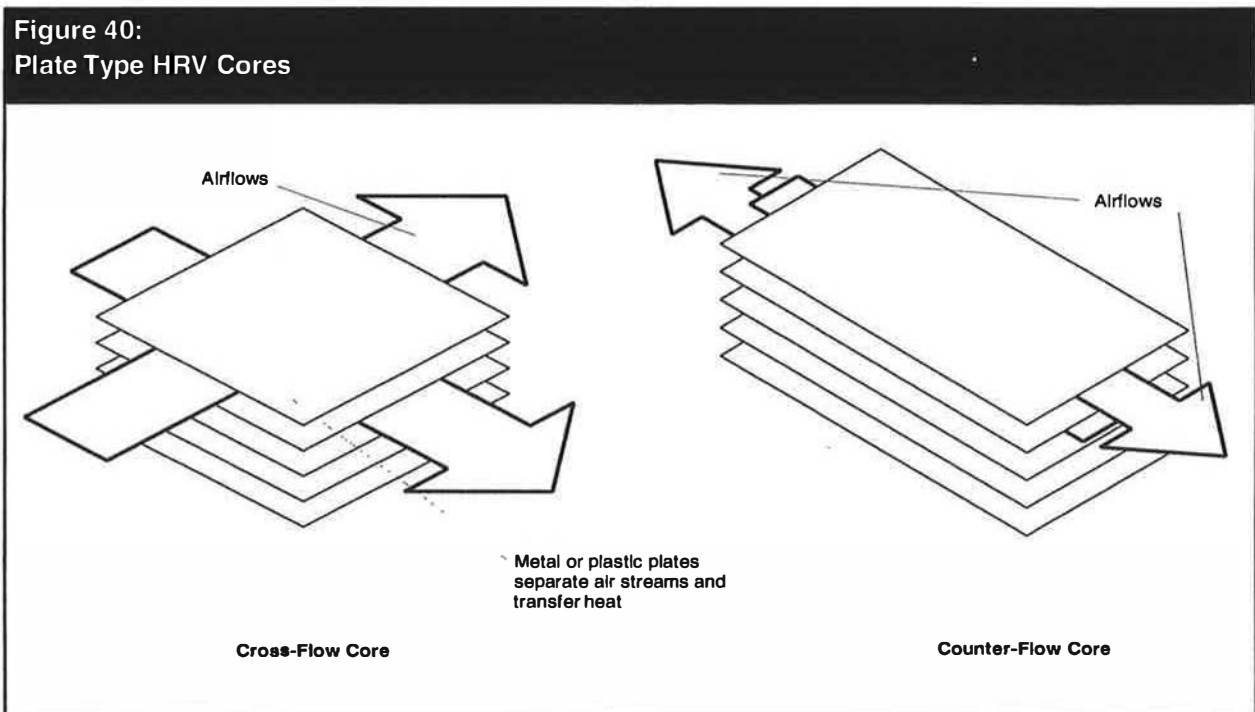

Figure 41:  
Rotary Wheel HRV Core

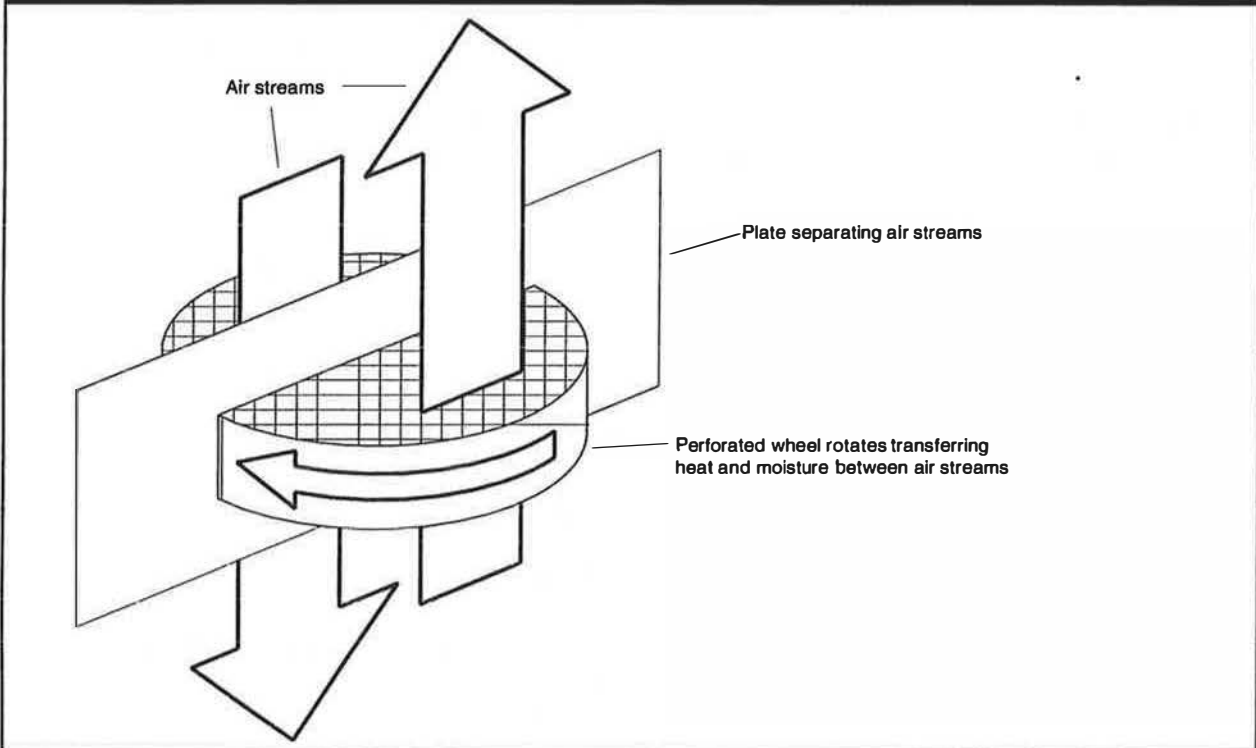
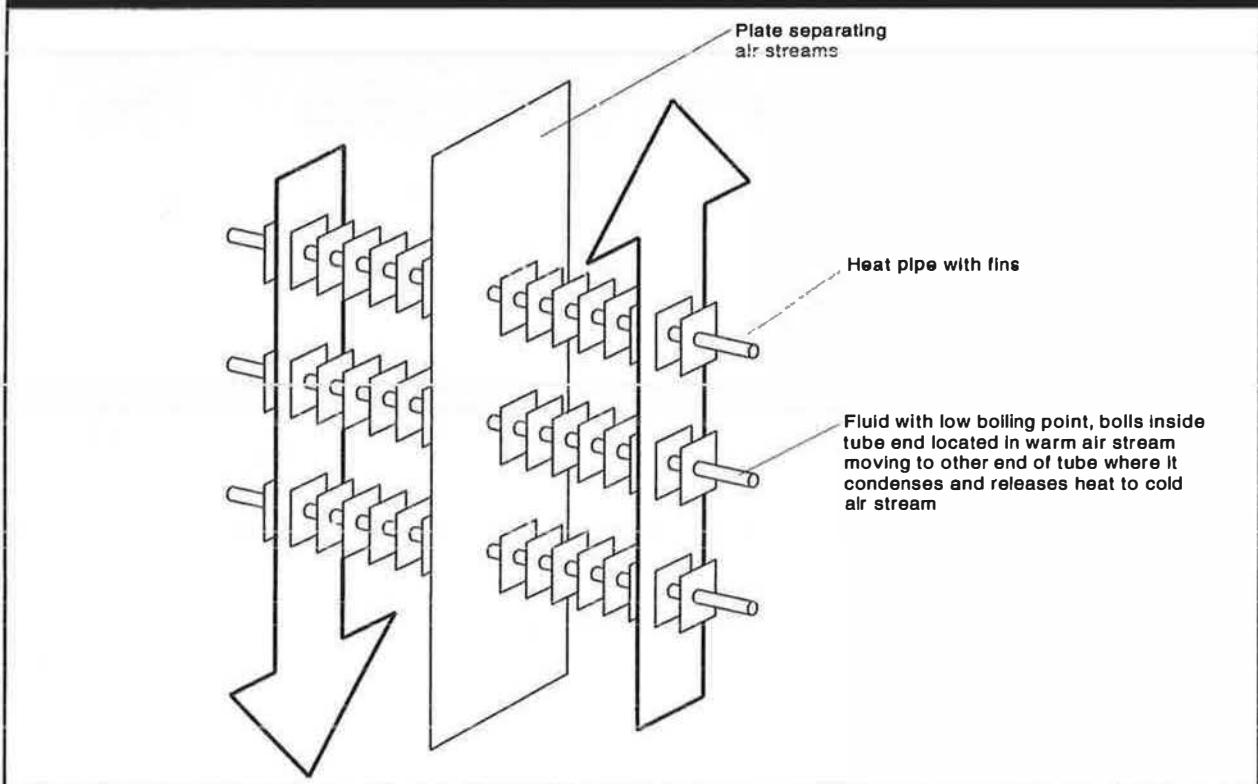

Figure 42:  
Heat Pipe HRV Core



types of units have heat recovery efficiencies in the 65 per cent range. Like plate core units, they do not transfer humidity between airstreams (Figure 42).

### **Cross leakage**

In all HRVs, a certain quantity of exhaust air will get into the supply airstream and be returned to the home (Figure 43). For plate core and heat pipe core units, typically one to three per cent of the exhaust air returns in the supply airstream. For rotary wheel cores, the percentage of exhaust air in the supply airstream is about 10 per cent. Rotary cores also transfer odours from exhaust air to supply air because the rotary wheel coating tends to cause odours to “cling” and later be released.

### **Defrost**

In the winter in most parts of Canada, the condensate formed inside the HRV core will become cold enough to freeze and eventually block the exhaust airstream. For this reason, some type of defrost device is usually included in HRVs. The most common defrost systems used are the following.

#### ***Electric preheat***

The outdoor air is heated before it enters the HRV so the condensate cannot freeze inside the core. This approach is low in initial cost but high in running cost, and may cause burned dust odours (Figure 43).

#### ***House air defrost***

The fresh air supply is shut off occasionally by an automatic damper, and warm house air is drawn into the unit. The heat from the house air, drawn through the supply side of the HRV core, melts the ice (Figure 43). This approach costs slightly more initially, but will cost less to operate than electric preheat in homes heated with combustion equipment or heat pumps. During the defrost cycle, the HRV is only exhausting air from the home which can

depressurize the home slightly, possibly causing backdrafting of naturally aspirated combustion appliances or temporary entry of soil gases through the foundation. These problems can be avoided by using sealed-combustion equipment and the correct foundation construction.

#### ***Recirculation defrost***

The exhaust air is recirculated through the supply air side of the HRV. This warms the core from both sides and melts the ice. In this approach, all the exhaust air taken from the bathrooms and kitchens is returned to other parts of the home during the defrost period (Figure 44).

#### ***Supply shutdown defrost***

The exhaust fan continues to operate. Since no heat is being drawn from the core by the intake stream, the core warms up and the ice melts. This approach means that during defrost the HRV is only exhausting air from the home which can depressurize the home. Similar precautions should be taken as for the house air defrost above (Figure 44).

### **Filters**

HRVs are typically supplied from the factory with a very basic filter that removes large dust and dirt particles and insects. Many HRV manufacturers also offer filter upgrades to medium-efficiency pleated filters or passive electrostatic filters which can be installed in place of the basic filter. Some manufacturers also offer add-on filter boxes which contain a series of filters such as activated carbon, electrostatic and medium-efficiency pleated filters. These boxes are usually located in the supply airstream between the HRV and the supply ducts. Refer to Chapter 6 for specific information on filter types and their performance.

### **HVI certification**

The Home Ventilating Institute, an independent North American ventilation testing agency, has adopted standard test methods for measuring the performance of HRVs. HVI-certified equipment

**Figure 43:**  
**Cross-Leakage and Defrost Methods in HRVs**

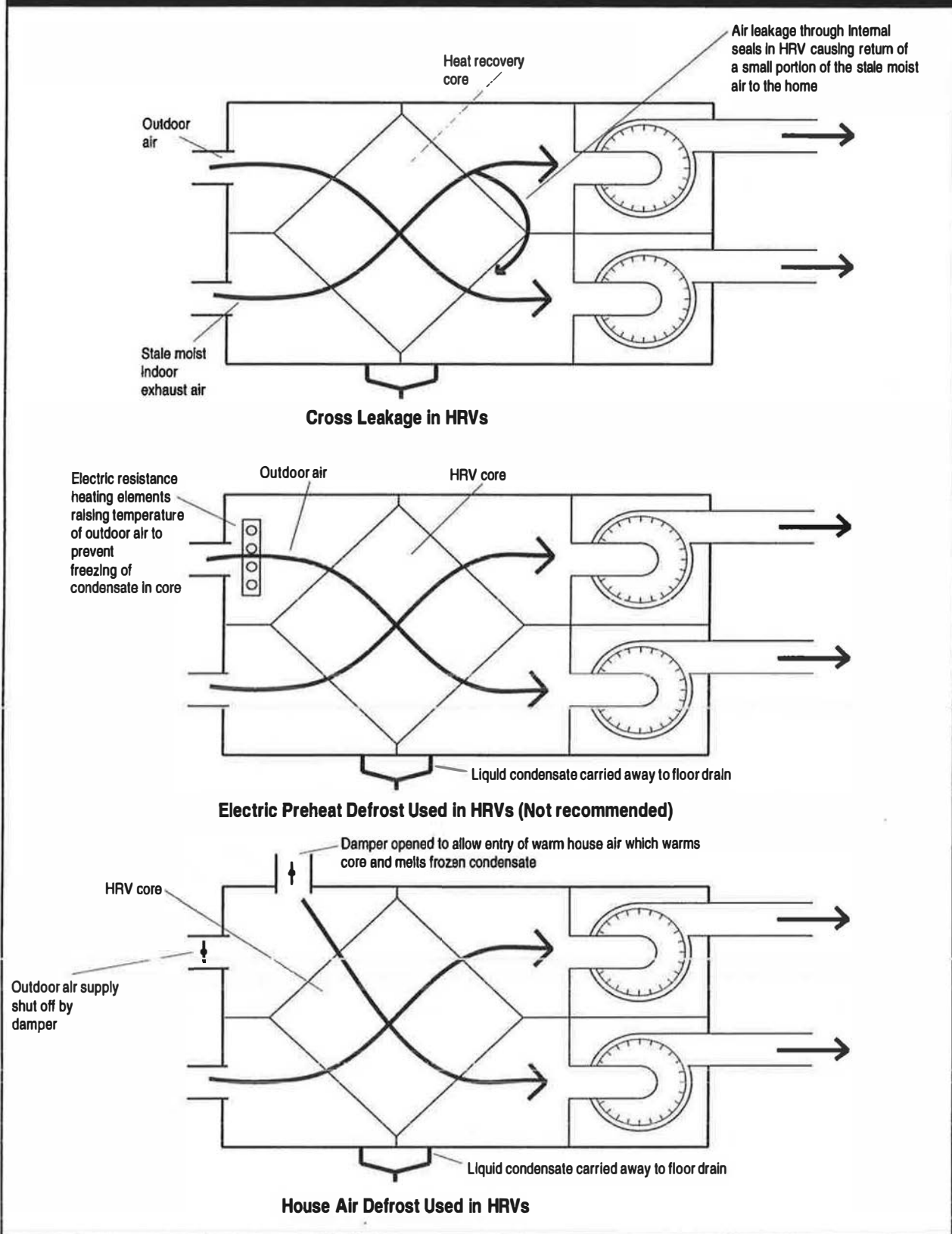
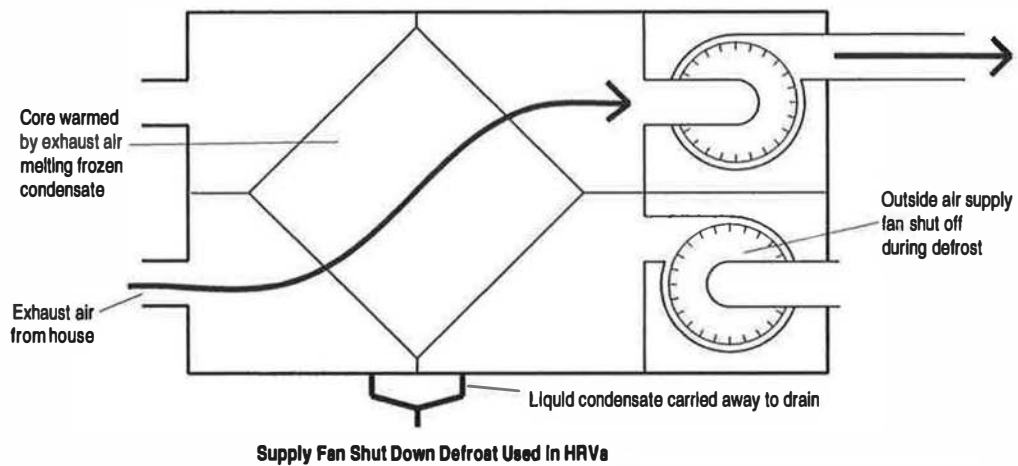
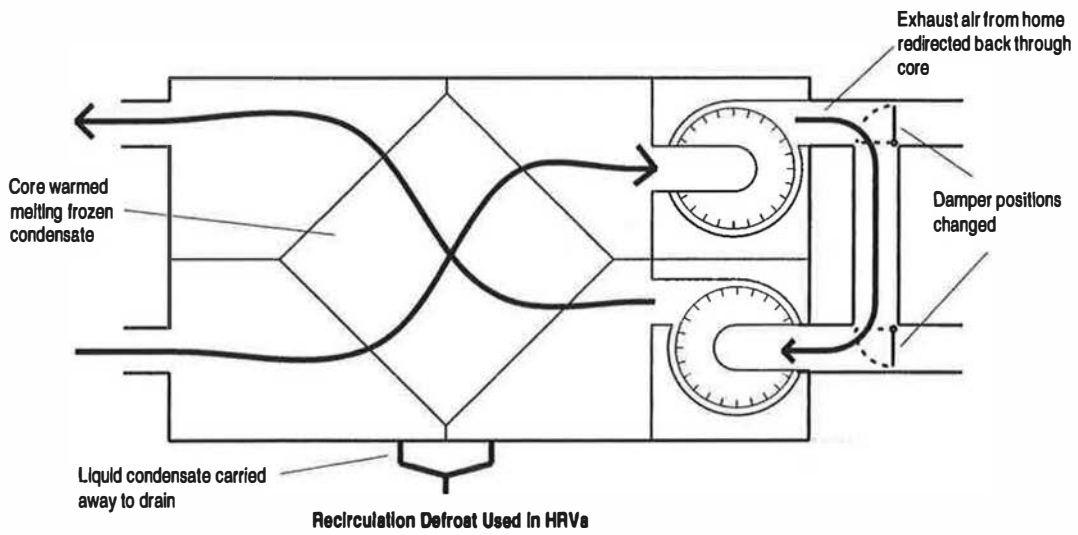
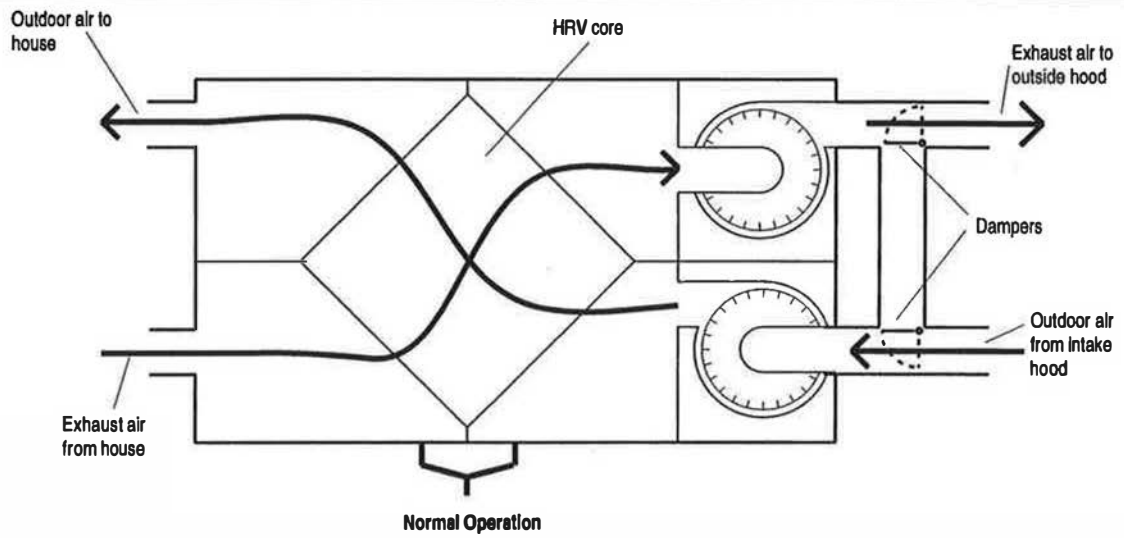

Figure 44:  
Other HRV Defrost Methods



has been tested by an independent HVI laboratory using these methods so performance can be fairly compared between models.

**Ventilation and HRV installation**

The importance of correct ventilation and HRV installation cannot be overemphasized. Good ventilation or HRV systems cannot overcome a poor installation. Ventilation systems and HRVs should only be installed by mechanical contractors who have been trained and certified by the Heating Refrigeration and Air Conditioning Institute of Canada (HRAI). Installers should have received HRAI's course on the CSA F326 standard, a national standard for home ventilation. In addition to good installation practices, the installer should be aware of the following requirements that further enhance indoor air quality.

- All sheet metal ductwork and fittings should be cleaned of oily residues with a non-perfumed soap or mild washing soda (sodium carbonate) solution and thoroughly rinsed with water.
- Aluminum foil tape should be used to seal all joints, seams and connections in the ductwork unless it has been established that the occupants can tolerate water-based (acrylic) liquid sealers.
- If house air defrost is used by the HRV, ensure that it is not drawing air from an area, such as a crawlspace, where air pollutants could be drawn into the HRV during the defrost cycle.
- Any added filtration should be located downstream of the HRV.

**Table 5:  
HRV Summary Table**

Heat Recovery Ventilator Types	IAQ Advantages	IAQ Disadvantages	Heat Recovery Efficiency Ranges
Plate core with electric preheat defrost	<ul style="list-style-type: none"> <li>• Low-odour metal or aged plastic cores available</li> <li>• Low cross-leakage</li> <li>• Continuous distribution of supply air through out the home</li> </ul>	<ul style="list-style-type: none"> <li>• Burnt dust odours during preheat</li> </ul>	70 to 80%
Plate core with house air defrost OR Plate core with supply fan shut-off	<ul style="list-style-type: none"> <li>• Low-odour metal or aged plastic cores available</li> <li>• Low cross-leakage</li> <li>• Continuous distribution of supply air throughout the home</li> </ul>	<ul style="list-style-type: none"> <li>• Places home under negative pressure during defrost possibly causing backdraft of naturally aspirated combustion appliances and entry of soil gases.</li> </ul>	70 to 80%
Plate core with exhaust air recirculation defrost	<ul style="list-style-type: none"> <li>• Low-odour metal or aged plastic cores available</li> <li>• Low cross-leakage</li> <li>• Continuous distribution of supply air throughout the home</li> </ul>	<ul style="list-style-type: none"> <li>• Returns all exhaust air into home when in defrost mode</li> </ul>	70-80%
Rotary wheel core electric preheat	<ul style="list-style-type: none"> <li>• Continuous distribution of supply air throughout the home</li> <li>• Humidity retention in winter</li> <li>• Dehumidification of ventilation air in summer</li> </ul>	<ul style="list-style-type: none"> <li>• Burnt dust odours during preheat</li> <li>• High cross leakage</li> <li>• Odour return from exhaust to supply</li> </ul>	80%
Heat pipe core with supply fan shut-off	<ul style="list-style-type: none"> <li>• Lowest cross-leakage</li> <li>• Continuous distribution of supply air throughout the home</li> </ul>	<ul style="list-style-type: none"> <li>• Places home under negative pressure during defrost, possibly causing backdraft of naturally aspirated combustion appliances and entry of soil gases</li> </ul>	65%



### Maintenance

The filters and the core have to be periodically cleaned. Clogged filters block the airflow and provide a medium for microbial contaminants to grow.

### Kitchen Range Exhaust (Outside Vented)

- Sheet metal hoods with grease filter and light. Fan may be in hood or remote-mounted.
- Downdraft exhaust is integrated with cook top/grille units.

### Other common names

- Range hood; and
- downdraft cook top exhaust.

### Typical system applications

Kitchen exhaust with any type of heating and ventilation system.

### Installation considerations and options

- Only outside vented units are effective; recirculating units are not recommended.
- Hood type units are more effective than downdraft of the same capacity.
- Remote blowers are quieter. Location is flexible, but must allow access for repair, replacement and cleaning.

### Health issues

#### Advantages

- Exhausting cooking odours and combustion products at source is an important air quality measure.
- High-capacity range exhausts with at least 200 L/S (424 cfm) flow, with remote-mounted blower are preferred.

### Disadvantages

- Large-capacity exhausts are incompatible with conventionally vented furnaces, water heaters and fireplaces, especially in draft-sealed houses. Pressure relief or supply air provisions must be made.

### General comments

*Only electric cookers should be used by the hypersensitive. Recirculation kitchen range exhausts should not be used by the hypersensitive.*

### Maintenance requirements

Regular grease filter cleaning.

### Operating cost/savings

Fan operation is inexpensive. Ventilation cost depends on heating system and other ventilation factors.

### Product sources

- Ventilation and heating contractors; and
- kitchen equipment suppliers.

See also the information on ventilation accessories in this chapter.

### Recirculating Central Ventilator

- A fan is installed in a box with exhaust ducts, a return duct, outside air intake and outside discharge. Air is mixed and recirculated by a baffle system.
- Primarily developed for moisture control. May incorporate basic filtration.

### Other common names

RCV.

### **Typical system applications**

For bathroom, kitchen and laundry exhaust with any type of heating system. Some supply air capacity.

### **Installation considerations and options**

Located similar to CEV or HRV in attic or basement.

### **Health issues**

#### *Advantages*

- Can provide adequate exhaust capacity for moisture control.

#### *Disadvantages*

- Outside air capacity is limited and not adequate for full ventilation requirements.
- Recirculating house air retains pollutants and mixes odours between rooms.

### **General comments**

RCVs do not provide a complete ventilation system for the home, but are appropriate for single rooms or as recirculation fans for use inside the home.

### **Maintenance requirements**

Occasional checks and cleaning.

### **Operating cost/savings**

Similar to other exhaust-only systems. Fan operation is inexpensive but RCVs have no ability to recover heating energy.

### **Product sources**

- Heating and ventilation contractors; and
- equipment manufacturers.

See also the information in this chapter on ventilation accessories.

## **Supplementary Ventilation Air Filtration for HRVs**

Additional particulate and possibly odour removal filters are installed in a sheet metal box connected to a supply air duct. The increased resistance to airflow from having additional filter media should be corrected by proper sizing of the HRV.

### **Other common names**

- Medium-efficiency filters;
- electrostatic filters; and
- odour removal filters.

### **Typical system applications**

Supply air filters for HRVs where outdoor air is contaminated. See Chapter 6 for filter details.

### **Installation considerations and options**

- Large filters must be used to minimize restriction.
- Access required for easy filter changes.
- Some reduction in ventilation airflow should be expected.

### **Health issues**

#### *Advantages*

- Can improve quality of air by reducing contaminants such as pollens, some automobile and industrial pollution, agricultural odours, etc.

#### *Disadvantages*

- One pass operation only. Must be effective filters.
- Will restrict airflow.

### General comments

- Minimum filter size is 300 mm x 300 mm x 25 mm (12 in. x 12 in. x 1 in.). Larger filters are preferred.
- Filter should fit tightly in housing to avoid bypassing.

### Maintenance requirements

Periodic filter changes.

### Product sources

- Ventilation and heating contractors; and
- specialty filtration suppliers.

See also the information on air filtration in Chapter 6.

### Registers, Grilles and Diffusers

- Hard plastic (usually PVC) molded units.
- Steel units.

### Other common names

Registers.

### Typical system applications

Supply exhaust and return points for CEV, RCV and HRV systems.

### Installation considerations and options

- Press-fitted into duct end or sealed with foil tape.
- A unique unit allows temporary full opening for high-exhaust capacity.
- Motorized damper and humidity-actuated units available.

### Health Issues

#### Advantages

- Metal units are preferable to the hypersensitive.

#### Disadvantages

- May contain gaskets and seals which have an odour to the hypersensitive.

### General comments

Metal units are usually painted. If paint odour is a problem, plated (brass, chrome and stainless steel) units are available, usually from commercial equipment suppliers.

### Maintenance requirements

None.

### Product sources

- Ventilation and heating contractors; and
- specialty ventilation suppliers.

See also the information on air filtration in Chapter 6.

## 5. HEATING AND VENTILATION SYSTEM RETROFITS

---

### **Adapting the Warm-Air Furnace**

Before modifying an existing furnace, the remaining lifetime of the furnace should be considered. The actual costs and benefits of replacing it with a more suitable model or a specially designed air handling system should then be compared. Often, a new furnace or heating system will result in lower energy costs due to higher-efficiency burners and motors. These will eventually offset some of the investment, typically in five to 15 years. The gas or electric utility, or fuel supplier will often have financing options available at favourable rates that can help to pay for replacement equipment.

If the furnace is fuel-fired, it should be checked for back venting and heat-exchanger condition before undertaking any significant work on the system. Any problems should be corrected, and if major problems are encountered, the furnace should be replaced with a more suitable model.

Because a furnace is certified for safety by a certification agency, there are few changes that can be made to the furnace without voiding the safety certification. Major changes are simply not permitted. Any modifications carried out to a furnace must be undertaken by a person with the appropriate fuel-safety or electrical qualifications.

### **Continuous blower operation**

If the furnace fan is to be operated continuously for ventilation or filtration reasons, a fan-only switch is frequently added. Often, in older, belt-drive equipment, only one speed will be available. High-speed operation may cause discomfort problems during the cold season while the burner is not operating, but will generally be acceptable during milder weather. If a second speed is required, the single-speed motor can usually be replaced. When electrical costs are considered, continuous low-speed operation is also less costly to operate than high speed. If a direct-drive motor is installed, a lower speed can likely be provided

for continuous operation through wiring changes. Conversion to two-speed operation will require the installation of a fan control relay on many furnaces.

### **Burner delay for oil furnaces**

Older oil furnaces tend to backdraft gases into the home, particularly when the chimney is cold, because the burner starts before a reliable draft has been established. A simple modification to reduce this problem is to add a solenoid valve delay unit to the burner. This device prevents oil from being injected into the burner until the burner blower has run for a short time and the flue draft has been more reliably established. These must be installed by a qualified burner service technician.

### **Blower motor replacement (belt drive motors)**

If the furnace has a belt-drive fan, the motor may be replaced with a totally enclosed, fan-cooled (TEFC) motor. The advantage of a TEFC motor is that the internal parts and windings are not exposed to the recirculating airstream. This avoids the contribution of contaminants from lubricating oils and motor insulation to the airstream. The housing and external parts of the new motor should be washed thoroughly before installation with a solution of washing soda (sodium carbonate) and warm water to remove any oil and grease. Unfortunately, totally enclosed replacement motors are not available for direct drive blowers.

If high-performance filtration or air conditioning are to be added to an older, forced air system, a new, more powerful fan motor may be required to overcome the added airflow resistance of these components.

### **Ductwork improvements**

Typically, conventional ductwork installations have many air leaks often located in areas where

contaminants may be picked up and circulated throughout the house. Return air ducts located in crawlspaces or damp and unconditioned basement areas are of particular concern, since they often draw contaminated air into the occupied areas. Air leaks into return air ducts can also cause local depressurization in the rooms where the furnace and water heater are located. Depressurization can cause increased soil gas entry and combustion gas spillage from the furnace or water heater.

Ductwork should be carefully sealed using aluminum foil tape or water-based liquid duct sealer (tested to be acceptable to the home occupants). Sealing should be carried out on the return air ductwork as a first priority, beginning at the furnace and working back toward the grilles. Particular attention should be paid to the point at which the main return air trunk is joined to any joist cavities which form return air branches. In some cases, particularly in older homes, joist cavities should be opened and lined with sheet metal to reduce dust pickup and filtering through from floors above, and to make ducts easier to clean. In older homes which have had insulation blown into the wall, the return air system should be carefully checked to see that insulation is not being drawn from walls into joist cavities that are used as return paths.

### **Adding air conditioning**

In houses with forced air systems, the most common approach for adding air conditioning is to install a coil connected to an air conditioner or heat pump in the central forced air furnace. The compressor and condenser are typically mounted in an outdoor unit. The evaporator coil is mounted in the furnace plenum and is fed by refrigerant lines from the compressor. See Chapter 3 for more information.

In houses without forced air systems or where it is not appropriate to operate the forced air system continuously, local air conditioners may be installed in specific rooms. The simplest of these is the basic window or wall-mounted air conditioner, though better-quality units are also available. See Chapter 3 for more information.

### **Furnace replacement**

If a decision is made to replace a furnace, the requirements for the replacement unit should be considered carefully. Should a furnace replacement be desirable, a quality, heat loss calculation should be performed and an authorized worksheet or computer printout should be presented to the homeowner. The ideal replacement system for forced air systems, where air quality is a high priority, is often a built-up system that contains the following basic components:

- a blower with a TEFC motor isolated from the airstream;
- a high-performance filter unit;
- a low-temperature heating coil supplied by a remote heat pump, sealed combustion boiler or water heater; and
- a cooling coil (if required) supplied by a remote heat pump or chiller unit (Figure 45).

A gas-fired domestic water heater with a fan-coil furnace attached is now available in Canada. This combined unit simplifies installation and has most of the features mentioned above. This type of system can have significant energy and operating cost benefits. Such a system may also include special filter units for removing gaseous air pollutants if required (see Chapter 6). Accurate sizing of the water heater is critical. The maximum legal limit for domestic water heaters is 60°C (140° F); therefore, the heat exchanger must be calculated at this temperature. Should the design water temperature be selected any higher than 60°C, not only will the residence receive inadequate heating, but there will also be problems maintaining a supply of domestic hot water.

### **Modifying electric baseboard heating systems**

The first decision to be made regarding electric baseboard heating is whether or not the baseboards will be kept. If the baseboards are to be kept, the ventilation, air filtration and other air treatment will typically be added locally, rather than as part of a central system. If there is enough

Figure 45:  
Built-Up Air Handler to Replace Furnace

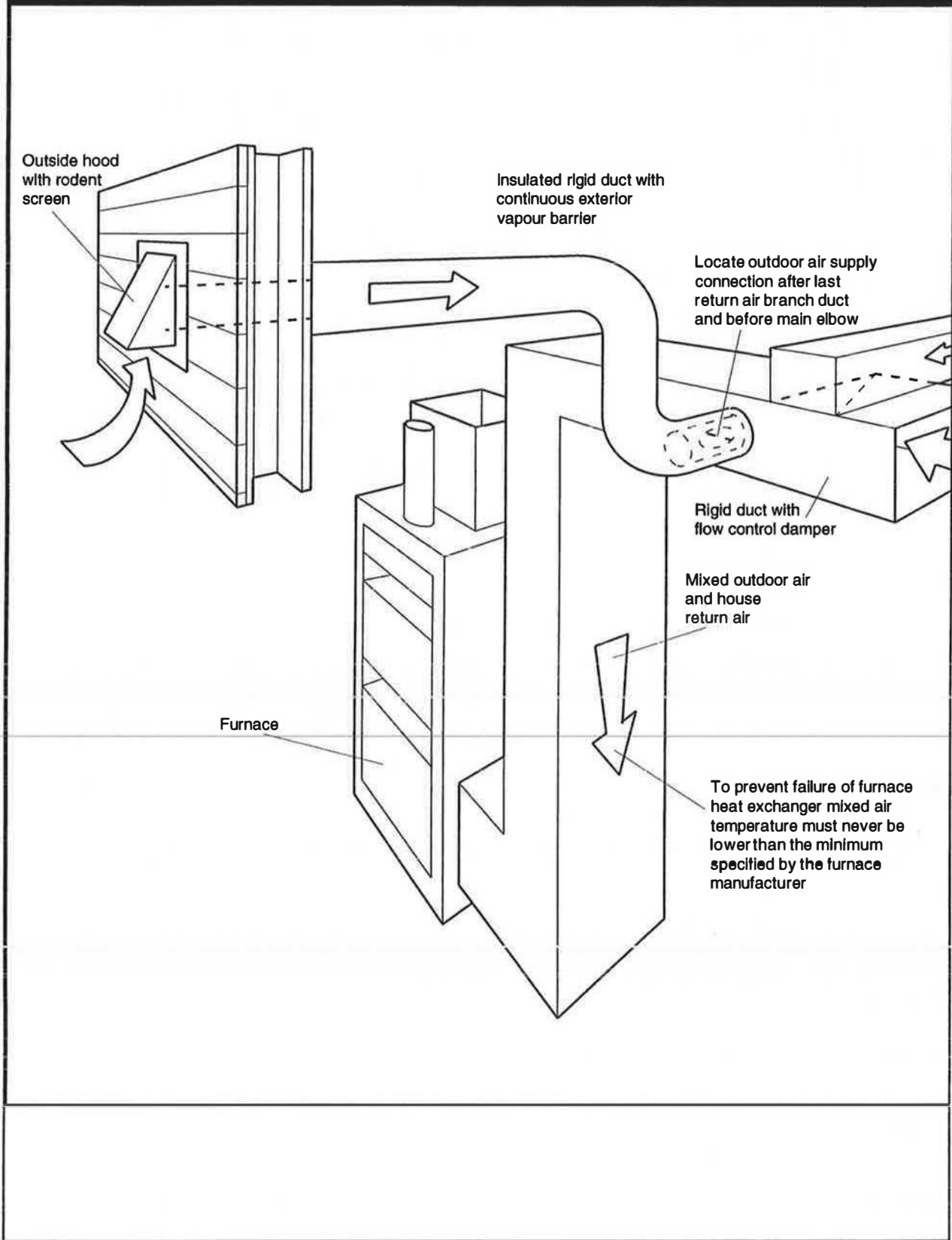

access for ducts, HRVs and air conditioners serving a few rooms are a common solution. The addition of a central ventilation system can also be done. However, if the baseboard heaters are a source of air quality complaints, due to their high surface temperatures and subsequent charring of dust particles, then they should be replaced. As an intermediate solution, they may be replaced with lower-watt-density units. The least expensive, lower-watt-density units are those standard electric models with lower capacity elements for their length. Liquid-filled electric baseboard heaters are a more costly option, but with other advantages.

### **Adding low-temperature radiant heating**

Radiant heating may sometimes be added to ceilings or walls in existing houses by placing it over existing surfaces. Floor installation of electric radiant heating may also be done by removing the ceiling below the room to be heated and applying hot water tubing to the underside of the floor above. However, this is an inefficient system so tubing with aluminum fins is sometimes used to improve heat transfer. Insulation is then placed in the cavity between the tubing and the ceiling below, and the ceiling is replaced. Radiant electric heat elements or mats may also be applied directly to an existing floor. For hydronic radiant heat, polybutylene or cross-linked polyethylene tubing is placed on the original floor and covered with a thin layer of concrete, lightweight concrete or gypsum concrete. A new finish floor will then be required on top of the heating system. This approach will result in a floor height difference between the room being heated and other rooms in the house, unless they are also converted. See Chapter 3 for a further discussion of these systems.

### **Adding ventilation and filtration equipment**

If exhaust-only ventilation is added to the whole house, there is no assurance that individual rooms will receive sufficient ventilation at all times, even if they are equipped with a wall-inlet slot. To ensure adequate ventilation air distribution, an RCV or recirculation system should be

installed. Typically, such a fan would remove air from the bath and closet locations and supply the air to the living areas of the house such as the bedrooms and living room. Exhaust points are typically located in kitchens and washrooms. The rate of air withdrawal or supply for a recirculation system should be at least 10 L/S (20 cfm) for a single bedroom and 20 L/S (40 cfm) for a master bedroom. Higher airflow rates provide better performance. See Chapter 4 for further discussion.

An HRV may be equipped with high-performance filters to treat incoming air fairly effectively. RCVs are usually more limited in filtration capacity. A portable or single-room filtration unit is one option, especially in sanctuary rooms. If air conditioning is added in the form of a window unit or mini split air conditioner, some filtering may be adapted. A mini split air conditioning unit can be operated continuously for filtration with less noise than a window unit. See Chapter 6 for more details.

### **Houses without a forced air system**

For houses without a central forced air heating system or where it is not appropriate to operate the heating system continuously, ventilation may be provided by an RCV serving a single room or a wider area of the house. Higher-quality and higher-volume ventilation may be provided by an HRV. Fresh air should be delivered directly to sleeping areas and may be removed from secondary areas such as washrooms or closets. See Chapter 4 for more details.

### **Houses with a forced air system**

For houses where a central forced air system exists and it is appropriate to operate it continuously, some ventilation may be provided by installing a duct from the outside, connected to the return air plenum of the furnace. Care should be taken when installing this duct that the airflow quantity is not too large (Figure 46). Excessive airflow can lead to discomfort and premature failure of some furnace components. However, the ventilation that may be provided in this way

is usually not sufficient to provide the recommended 5 L/S (10 cfm) per room.

Additional ventilation equipment will be needed. If the furnace is equipped with high-performance filtration, then the incoming outside air will also be well filtered before being delivered to the space.

Another option is to install an HRV and duct the preheated outdoor air from the HRV into the return air plenum of the furnace (Figure 47). Exhaust ducting should be run where possible to bathrooms, laundry rooms and the kitchen. This is often done by passing the ductwork through closets and unfinished spaces in the house.

### Adding air filtration and odour removal

For houses with forced air systems, high-performance dust filtration and possibly odour

and pollutant-removal systems are normally added to the existing filter location at the return air side of the furnace. When adding high-performance filters, it is essential that the filter's resistance to airflow be taken into account. Adding a medium-performance, extended media filter to an existing furnace will probably not require blower modifications, even if it contains an activated charcoal treatment, nor will adding an electrostatic unit. However, adding multiple filters or a bag filter will usually require blower upgrading due to the airflow resistance. See Chapter 6 for more information.

All particle filter and odour removal units will provide less resistance to airflow and improved effectiveness if the air entering them is distributed as evenly as possible across their face. Electronic air filters will also produce lower levels of ozone, if the air entering them is well distributed. These units are more sensitive to a proper airflow rate

Figure 46:  
Outside Air Connection

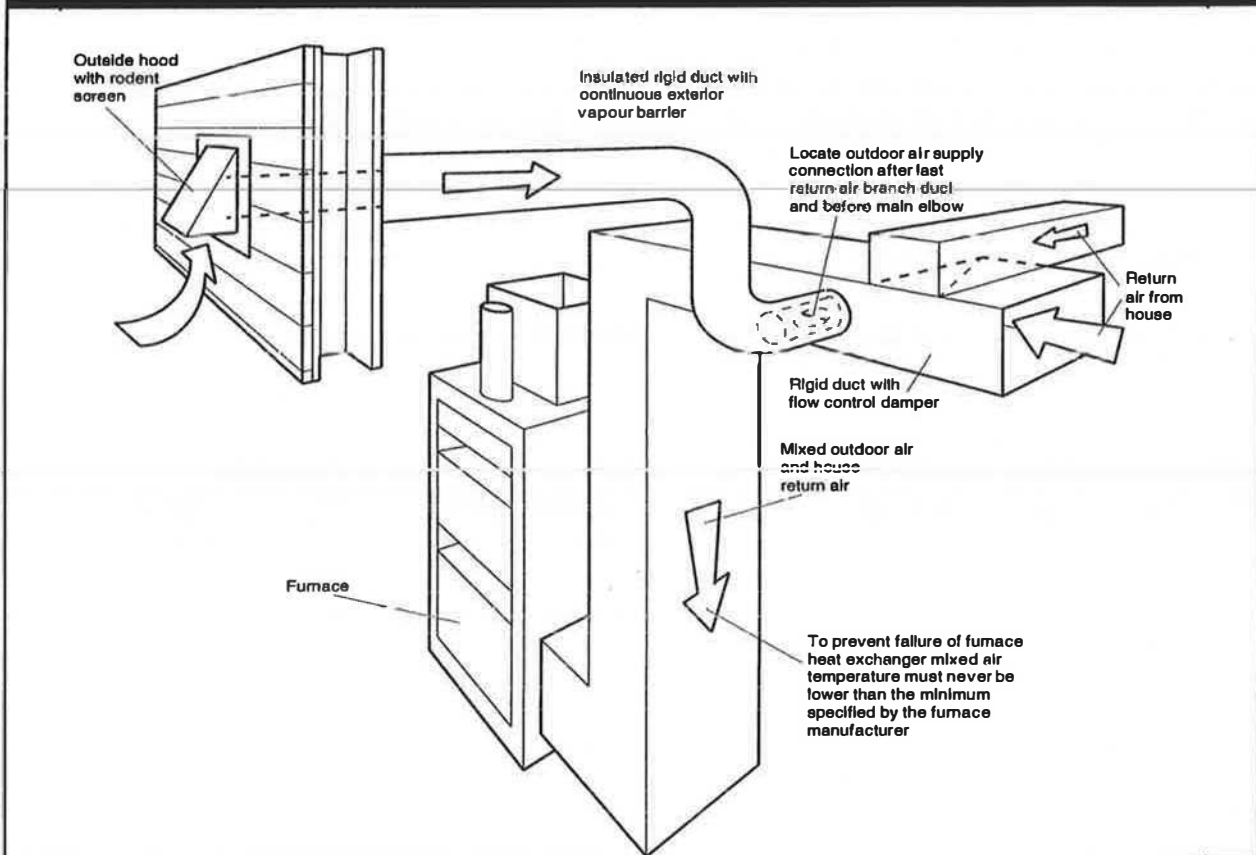
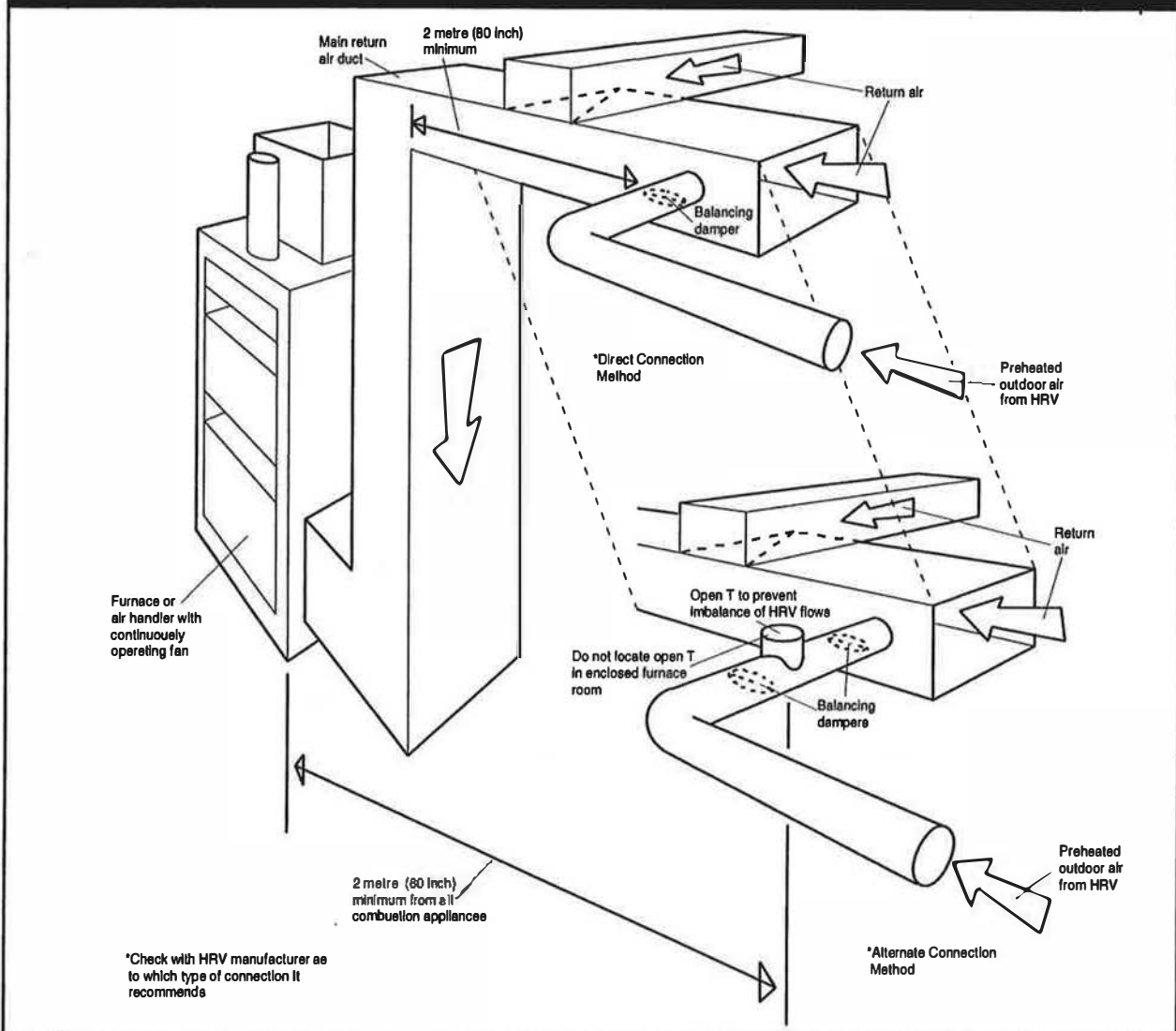



Figure 47:  
HRV Connection to Forced Air Heating System



and distribution than other filters. All filter and scrubbing units should be located after a length of straight duct or after an elbow with splitters or turning vanes (devices for reducing turbulence in duct elbows). Any locations after elbows without splitters or turning vanes will experience uneven airflow (Figures 48 and 49).

In most existing furnaces, adding filters will require some sheet metal modification. A sheet metal or mechanical contractor can install shelving on the return duct to hold standard 2.5 cm (1 in.) thick particulate filters or trays to hold the odour removal media. The trays can be

2.5 cm, 5 cm (1 in., 2 in.) or thicker. Some heating contractors can order these trays from suppliers or fabricate them from galvanized metal and metal screening. The mesh should be adequate to retain the filter media. These trays usually have a hole at the narrow face for refilling. A door in the ductwork should permit easy access to the filters.

HEPA (high efficiency particulate arrestance) filters are not normally installed on a central forced air system without modifications because their resistance to airflow is too high. HEPA filters are normally used only in local

Figure 48:  
New Filter Location with Length of Straight Duct before the Filter

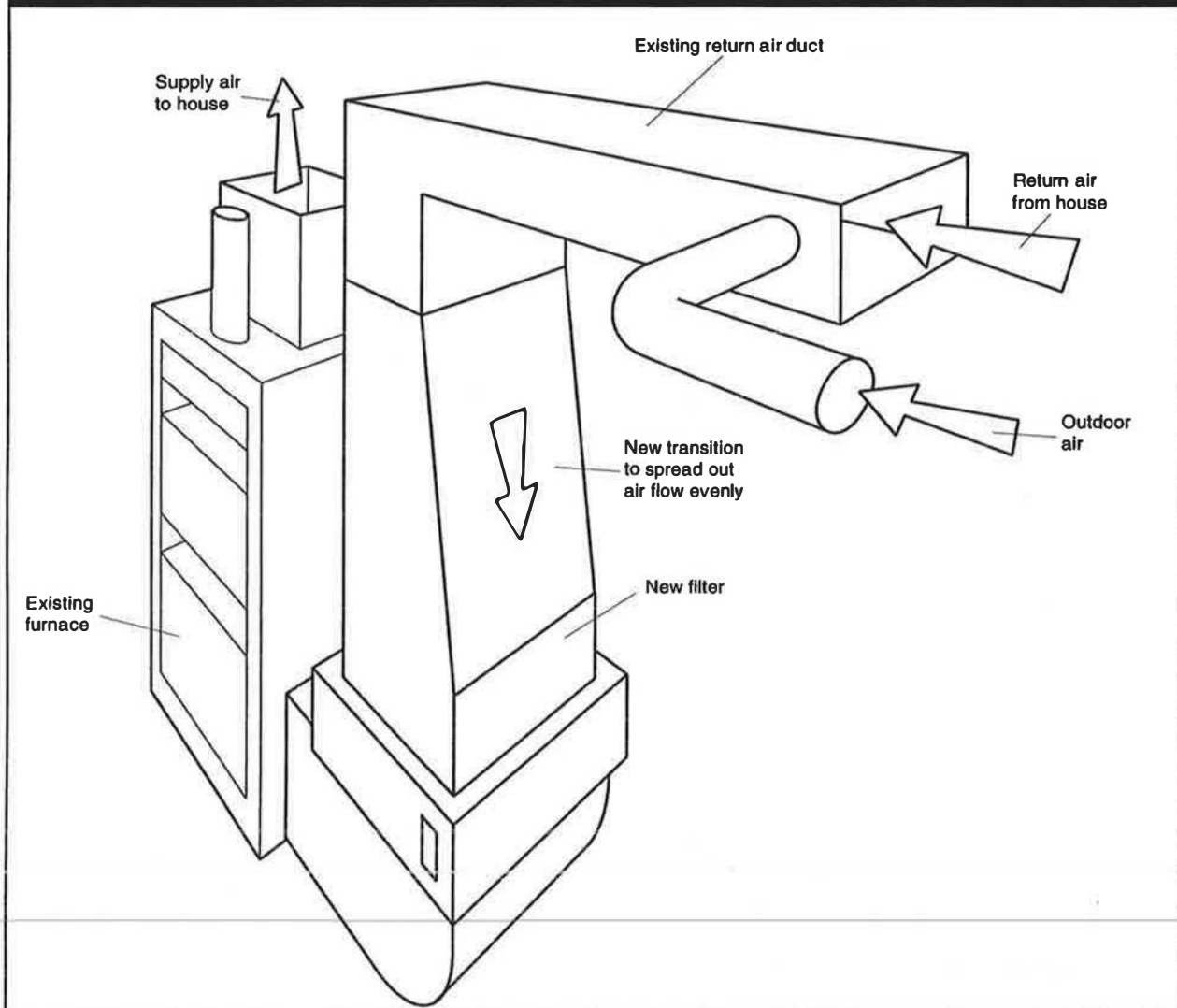

and portable air cleaning units with high-pressure fans.

Local filter units which attach to individual warm air registers are not recommended, due to the imbalance in airflow that can be caused. However, if the room remains adequately heated or cooled with a local filter unit in place, it may be appropriate.

An "air scrubbing unit" that contains filtration and absorption material may also be installed in the branch duct serving an individual room; however, a booster blower will usually be required to overcome the added resistance

of the scrubber unit. The booster blower can be operated by an independent thermostat for the room being served or it may be interlocked with the main fan control for the furnace.

#### Using and maintaining portable equipment

Portable equipment used for single-room air cleaning includes medium-efficiency or HEPA filtration and may include electrostatic air cleaners or adsorption units for gas removal. Portable humidification and dehumidification equipment may also be used. Portable humidifiers are not recommended, except for steam types. If steam humidifiers are used, it is preferable to use

Figure 49:  
Filter Location with New Bottom Elbow

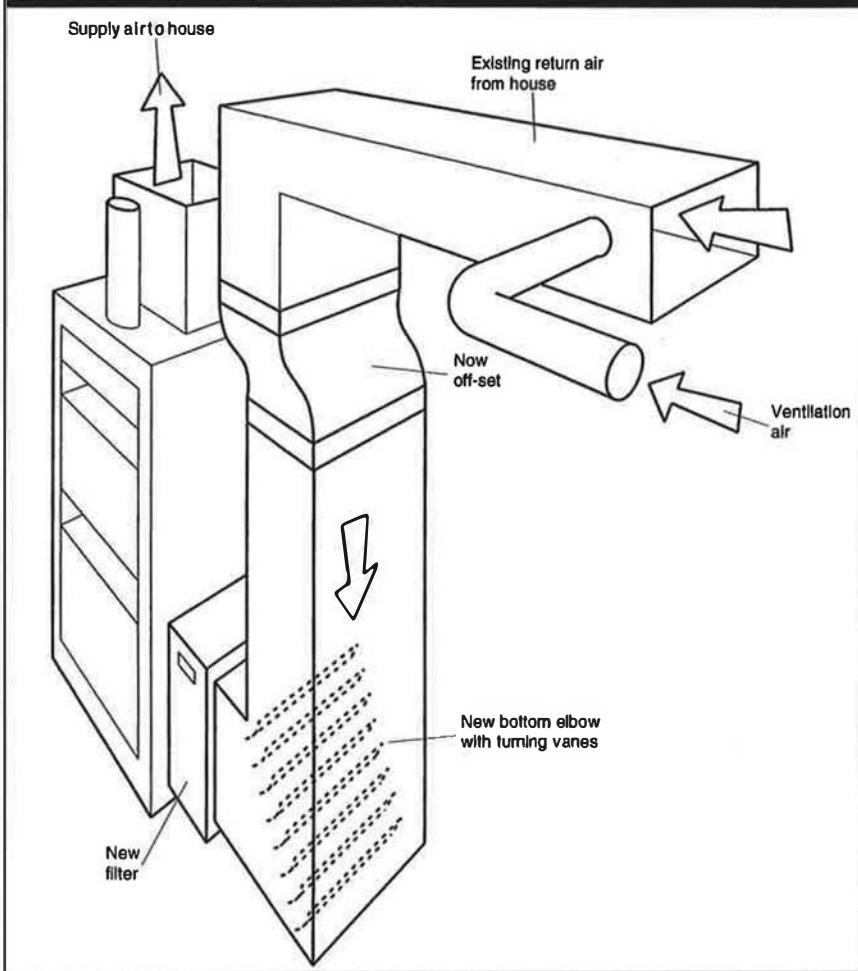

filters and odour-absorbing materials. A variety of odour removal materials, each with unique gas absorption abilities, may be obtained. Portable units are particularly useful when travelling, but will only serve fully enclosed rooms of a limited size. See Chapter 6 for more information.

Higher-capacity portable filtration units (often with HEPA filters) are available beginning with 12 kg. (27 lb.) consoles and ranging up to very large, cabinet-sized units. These units typically include a pre-filter, blower and HEPA cartridge. Many units also provide for odour removal material such as activated carbon. The pre-filter on such a unit should be replaced frequently, at least twice yearly. The HEPA filter cassette is very long lasting, and lifetimes of two years or more are possible. Whenever these units are serviced, it is

best to remove them from the space being treated, to an outdoor location or to another area such as a garage. The filter units may then be replaced without the possibility of recontaminating the room with filter dust. The blower and cabinet should also be vacuumed at this time. A personal respirator should always be worn when changing filters.

distilled water to prevent mineral and other contamination. The humidifier and the water reservoir should be cleaned weekly.

Small, tabletop air cleaners are available which weigh from 4 kg to 8 kg (10 lbs to 20 lbs) and are suitable for single rooms, offices or cars. They require periodic replacement of the

## 6. FILTRATION AND AIR CLEANING SYSTEMS

---

### The Purpose of Filtration

Air filtration is usually incorporated into a forced air system to remove contaminants in the air supplied to occupants. Homes with other types of heating usually have no filtration. Filtration may also be incorporated into a ventilation system or sometimes into special systems which filter recirculating air.

Basic air filtration reduces the quantity of particulates (dust, particles, pollens, molds) suspended in the air of the home. This is important to reduce:

- the quantity of particulates which are likely to be inhaled;
- the need for housecleaning and furnace duct cleaning;
- the quantity of particulates reaching hot surfaces in heating systems;
- the accumulation of dust on moist surfaces which can support microbial growth; and
- inhalants that may aggravate or cause allergic or asthmatic reactions.

It also protects the heating, air conditioning and ventilation equipment.

House dust is a mixture of fine and coarse particles from many sources including allergenic fungi, animal dander and pollens, hazardous mineral fibres, and relatively harmless textile fibres and soils. The larger particles, such as fibres shed from fabrics, tend to be just housekeeping nuisances as they are not easily inhaled deep into the respiratory system. These larger particles are the ones which are usually trapped by common filters such as standard furnace filters. The finer particles, those less than about 10 microns (ten thousandths of a millimetre), are more hazardous because they can enter the bronchia and lungs. These can only be effectively trapped by medium- and high-performance filters.

In homes without air filtration, as is the case with homes having convection or radiant heating systems containing no fans and filters, dust must be controlled more rigorously by careful and continuous housekeeping. Where pollens and dust from outdoor sources may be a problem, or where respiratory illness is clearly linked to outdoor air pollutants, a system of air filtration is usually necessary.

Typically, filters only remove particles from air. Specialized filters are required to remove odours and other gaseous air pollutants from combustion, smoking, cooking, cleaning and hobby materials, automobiles, industrial activity, furnishings and building material emissions. Because they are difficult to remove or dilute by ventilation, gaseous pollutants should be avoided through source control. However, in some cases gas removal may be necessary.

### Particulate Filters

A variety of particle filters is available for home heating systems ranging from the limited dust-removal capacity of a conventional furnace filter to the high-performance pollen and fungal spore-removal ability of a bag filter or an electrostatic filter. Particle filters are used in portable air cleaners, ventilation systems and custom whole-house air cleaners, as well as very high-performance filters which can trap bacteria.

### Sieve type

A sieve-type filter, also called a mechanical filter, is simply a fine strainer which traps some of the particles from the air passing through it. These filters are made from filter media, the most common of which are glass or silicate fibre mesh, woven fabrics of synthetic or natural fibres, including all-cotton fabric or plastic foams. Sieve filters may also be made from metal screens, though these are generally used only for large particles and grease-catching tasks such as those in kitchen range exhausts.

Though sieve filters can be extremely fine and capable of efficiently trapping very small particles, their resistance to the passage of air increases accordingly with the amount captured. Therefore, most sieve filters are generally limited to medium-efficiency ranges so they will not present too much resistance to airflow. Extended media filters are those which are folded into pleated or bag shapes to extend their surface area, allowing increased efficiency without restricting airflow excessively. Some mechanical filters perform better when moderately loaded.

The most common types of sieve filters are:

**Group one**

- Typical furnace filters; low efficiency and low resistance to airflow.
- Useful only for coarse filtration to protect equipment, and pre-filtering to protect finer filters and gas removal filters.
- Traps textile fibres, hair and coarse dust greater than 10 microns.

**Groups one and two**

- Pleated, extended media; medium efficiency and low to medium resistance to airflow.
- Commonly used as a furnace filter upgrade, or in air cleaners.
- Traps some pollens, animal dander, fungal spores and fine soil particles in the five micron range (Figure 50).

**Group two**

- Bag-type, extended media; medium to high efficiency and medium to high resistance to airflow.
- Commonly used in special air cleaning systems, portable filters and with fan-coil, forced air systems equipped with high pressure fans.

- A wide range of efficiencies are available, up to hospital clean-room standard. These are capable of trapping pollens, fungal spores, fine soil and some bacteria in the one micron range (Figure 51).

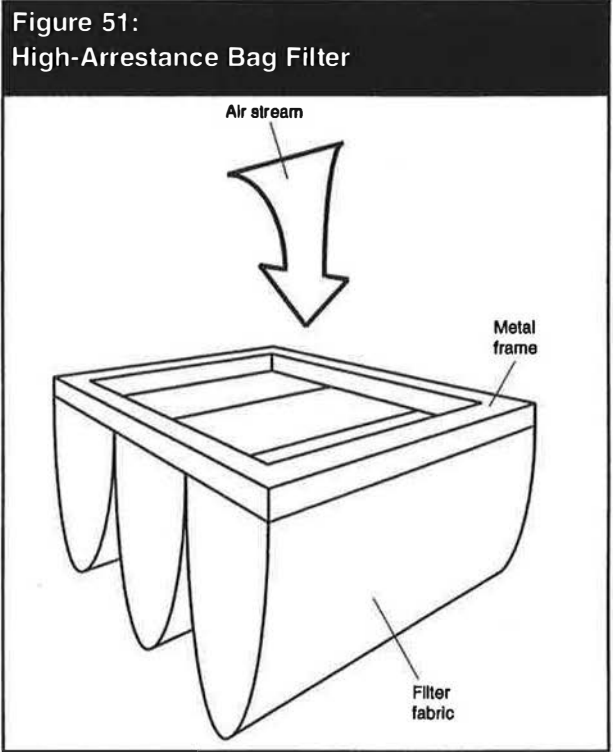
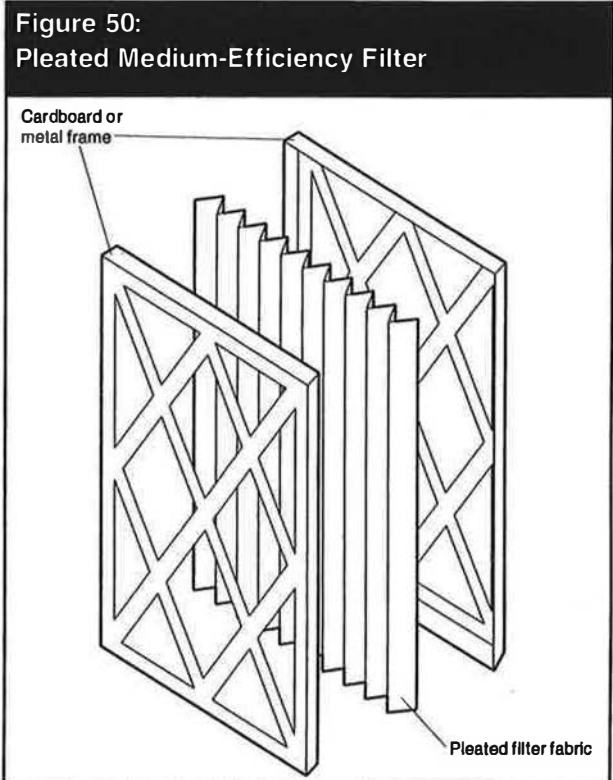

### **Group three**

- HEPA, extended media; very high efficiency and very high resistance to airflow.
- Commonly used in hospital and industrial clean-room situations and occasionally in high-performance portable air cleaners or custom filter systems.
- Biological grade is capable of trapping bacteria as well as other very fine particles. Up to 99.9 per cent efficient for 0.3 micron particles.

Filter efficiency for trapping small particles is not only a function of the size of the openings in the filter, but also of sticky materials with which it may be coated. For example, some sieve filters may have an oily or electrostatically charged coating (sometimes called an electret) which aids in trapping fine dust when the filter is new. (See the information on filter coatings in this chapter.) As the filter becomes loaded with dust, its efficiency for trapping small particles then improves because it is less porous. Eventually, like all filters, it presents too much resistance to airflow to be useful.

### **Electrostatic filters**

This filter uses small static electrical charges, supplied by the house current, to trap dust on woven screens or wire grids. The principle is that dust particles are electrically charged, causing them to be repelled by one charged mesh and attracted to another. There are two distinct types of electrostatics: the passive electrostatic and the electronic filter. Unlike the disposable sieve filters, both types of electrostatics are semi-permanent units which require minimum quarterly cleaning and washing to remove accumulated dust. They will last many years. Both electrostatic and electronic filters should be used with continuous, low speed fan operation (Figure 48).

### **Passive electrostatic filters**

These units use grids of fine, polypropylene strands with or without a polyester sheet between the grids. These retain a small static electrical charge which is renewed by the movement of air over them. Charged dust particles passing through the grid tend to stick to the strands. These are commonly used as retrofit furnace filters and in portable air cleaners. They are effective for trapping fine dust such as pollens in the five micron range. They use no electricity and produce no ozone gas.

### **Electronic filters**

The electronic filter works by a similar principle, but the grids are made from metal wires or fins which are charged by a high-voltage electrical supply. They are more effective than the passive electrostatics at trapping fine dust, such as pollen, but also produce small amounts of ozone, an irritating gas. The concentration of ozone will increase if the filter is poorly maintained, infrequently cleaned or inappropriately installed. Ozone can affect asthmatics and those with severe respiratory sensitivity. These units also produce a characteristic crackling or popping noise.

### **Turbulent flow precipitator**

Turbulent flow precipitator (TFP) is a new type of filter which does not use filter media. It can remove particles as small as 0.1 micron. Particles are separated from the airstream by means of a turbulent airflow. The performance of the unit is not affected by the loading since the air particles are captured in a separate compartment. Maintenance involves cleaning this compartment annually.

### **Ion generators**

Air ionization is the process of altering the electrical charge on gas molecules in the air.

Though generally thought of as an odour control method or a means of enhancing a feeling of well-being through altering ion balance, ionization has also been used for particulate removal. Some very small particles are maintained suspended in air because they carry static electric charges which cause them to be repelled by walls and floors. These are difficult to trap with conventional air filters. An ion generator produces ions which alter the charge on particles, which in turn, alter other particles nearby. Suspended particles which have had their charge altered tend to fall to the floor where they can be picked up by cleaning or get attracted to some collector. This effect is not well proven and has drawbacks such as increased accumulation of dust on floors.

The use of ionization for odour control and enhanced well-being discussed later in this chapter under other special considerations, should be distinguished from its use for particle removal.

#### **Filter performance**

Filters are commonly rated between about 40 and 95 per cent efficient for a given particle size and test method. There are several test methods used, usually those defined by the ASHRAE Standard 52-76 (The American Society of Heating, Refrigeration and Air-conditioning Engineers). Stated particulate filter efficiency is only meaningful if the test method is declared.

The least rigorous test method is the arrestance method. Units such as conventional furnace filters, foams and metal screens fall into the 50 to 80 per cent efficiency range by this method. These are called group one filters and are not particularly effective for fine dust. More effective filters such as pleated fabric panels begin at about 90 per cent arrestance efficiency and reach about 97 per cent. These are classed as group two or medium efficiency. More effective filters, such as bags or electrostatics, begin at about 94 per cent arrestance efficiency and reach about 99 per cent. These are classed as group three.

The next most rigorous test method is the atmospheric (or dust spot) method. Pleated

fabric panel filters of the group two type are rated for about 20 to 30 per cent atmospheric efficiency. Group three bag filters and electrostatics are rated at about 30 to 70 per cent atmospheric efficiency.

The most rigorous test method is the DOP (Di-octyl phthalate or military standard) named after a chemical which is used in an atomized form for filter testing. DOP particles are very small, about 0.3 microns and can only be trapped by the most effective filters. This test method is usually only used for very high-performance filters, such as HEPA units, which are not commonly used in homes. The best of the group three filters, such as the high-performance bag filters and electrostatics, are rated at about 10 to 30 per cent DOP efficiency.

Typical medium-efficiency filters for home use should be rated at about 94 per cent arrestance efficiency or 30 per cent atmospheric efficiency. This is the minimum recommendation in environmentally hypersensitive applications. If high-performance filters are desired, they should be rated at about 98 per cent arrestance efficiency or 60 per cent atmospheric. If very high-performance filters are used, they may exceed 99.8 per cent arrestance efficiency or 85 per cent atmospheric. These units must only be used where their resistance to airflow is acceptable for the equipment.

#### **Odour removal**

Removal of gases from air requires different methods than particle removal and different equipment. There are two methods which can be used: adsorption and reactive scrubbing. Unlike sieve filters which differ mainly in their efficiency at trapping particles of a certain size, adsorption and reactive scrubbing materials must be specifically selected for the gases they are intended to remove. Some of the important variables, among the hundreds of gases which can be trapped, are the size of the gas molecule, its reactivity and its ability to form acids or alkalis.

### ***Gaseous adsorbents***

An adsorption material is one which contains microscopic pores or surface irregularities able to trap molecules of gases on its surfaces where they can be held until disposed. Activated carbon and crystalline zeolite are common types of adsorbent material.

- Activated carbon (charcoal), the most common and broadly effective gas adsorption material, is effective for many solvent odours, diesel and other fuels, alcohol odours, body and bathroom odours, cooking, dry cleaning, paint and adhesive odours, and pet odours. It is not highly effective for formaldehyde, ammonia and some irritating components of urban smog, such as sulphur and nitrogen oxides. Generally, it is least effective for compounds with low molecular weight. Activated carbon is usually made from wood, coconut shell or peat.
- Zeolite, mined from mineral deposits, is particularly effective for ammonia odours from pets and urine spills. Generally, it is most effective for compounds which are alkaline. Zeolite is not a substitute for carbon for general odour removal purposes, but can be an important supplement.

Adsorption filters will usually collect moisture quite readily and begin to deteriorate if used in damp locations. They should only be used in a dry airstream which is relatively free of particles and oily substances.

### ***Reactive scrubbers***

Reactive scrubbers actually react chemically with gases and render them inert or stable until they can be disposed. These are also called absorbers. Potassium permanganate on a base of activated alumina is a common type of reactive scrubber material.

- Potassium permanganate on alumina is particularly effective for formaldehyde, hydrogen sulphide (rotten egg odour), odourants in natural gas and acid materials.

- Formaldehyde scrubbers—specially formulated formaldehyde gas removal materials—are available which are quite specific for this compound. They typically contain sulphite or ammonia compounds. These can be dispersed in a filter fabric or compressed into a pellet form and contained in porous bags.
- Acid scrubbers are useful where acid or chlorine odours are a problem, such as in a photographic lab or chlorinated pool. A strong alkaline material, such as sodium hydroxide (lye), is sometimes applied to an inert base for gas removal. These are also effective for iodine and other halogen gases, as well as many acids.
- Other specialized scrubbers are used in situations where specific irritants can be identified which cannot be avoided. A custom reactive filter can often be prepared which will solve a problem. This is possible even for air contaminants which are not effectively removed by conventional gas removal agents. This work must be done by a qualified filtration consultant.

Filters designed specifically for adsorption or reactive scrubbing are also capable of trapping small particles, but should not be used primarily for this purpose. Their effectiveness diminishes as they become clogged with particles, and they are costly and tedious to replace. This type of filter should always be located after a particle filter which can protect it from clogging. The filter media can also be a source of fine particulates. The trays should be vacuumed to remove loose dust, and a particulate filter should be installed past the filter media.

Specially treated filter fabrics, such as glass and polyester mats and cotton fabric, are also available, treated with charcoal for odour removal. These filters can trap both particles and gases and are useful where both functions must be accommodated in a small space. For example, a charcoal-treated, pleated filter can be installed in a forced air system for dust and odour removal. However, due to the limited quantity of charcoal,



and the increased restriction to airflow, these should be used only where space is limited. They are more costly to replace than an untreated filter.

## **Installation and Use**

### **Filter location**

Air filters are most effective when they receive a recirculated airstream such as the filter in a forced air furnace or a portable room air cleaner. The reason for this is that trapping particles or gases in a filter is largely a matter of chance. Therefore, the more times contaminated air is passed through a filter, the better the chances of trapping contaminants. However, filters are sometimes used in single-pass locations such as ventilation supply ducts. In this case, the efficiency of the filter becomes critical since there will only be one chance to trap contaminants.

### **Filter restriction to airflow**

All filters present some resistance to the flow of air. As the filters become loaded, the resistance increases. This resistance is usually expressed as air pressure (pascals or inches of water column) at a given airflow rate (litres/sec. or cfm). For example, a filter may be rated at 0.6 in. WC at 500 cfm. (236 L/S). This means that at a 500 cfm airflow rate, it presents resistance pressure equal to a column of water 0.6 inches high. This pressure can also be expressed as 150 pascals. It is critically important that filter resistance be matched to the fan and motor in which it is used. If resistance is too high for the fan, the filter and the equipment will not perform effectively. This is important for high-performance filters and for filter upgrades for forced air heating and ventilation systems. This should be determined by a qualified heating and ventilation contractor or consultant.

One reason that electrostatic filters are so popular for air cleaners and furnace upgrades is that they present relatively little resistance to airflow, yet provide medium- to high-efficiency performance.

### **Filter maintenance**

Filter maintenance is critical to proper operation. Regular checks, washing or replacement is essential. Sieve filters, such as standard furnace filters, extended media filters and high-performance filters, often become more efficient as they become loaded with dust. As they become fully loaded, however, they begin to restrict the airstream to the point where they reduce the performance of the fan which moves air through them. In fact, a fully loaded furnace filter can reduce air movement through the furnace heat exchanger to the point where the furnace will no longer function. This will normally not happen unless replacement is severely neglected. Standard and medium-efficiency furnace filters, used in forced air heating may require replacement, two to four times annually. High-performance filters, such as bag filters, are often used after a standard filter and may only need annual replacement or less, due to their large surface area.

Unlike sieve filters, electrostatic filters quickly become less efficient as they become loaded. As soon as the screens or grids are coated with dust, they have a limited ability to attract more dust. These are permanent units, however, and can be easily cleaned. Some people clean them frequently during the heating season.

Adsorption and reactive scrubbers also become less efficient as they become loaded. In fact, if used in heavily contaminated circumstances, they will eventually cease to have any effect and, particularly adsorption media, will begin to release the compounds they have trapped back into the airstream. They may also become contaminated with bacteria or fungi if used under humid conditions. For these reasons, regular replacement of adsorption and reactive media filters is more critical than it is for sieve filters.

Filters used in portable room air cleaners may include any or all four types discussed above. These will have widely variable servicing requirements based on equipment type, room size, operating hours and quantity of air contaminants.

**Table 6:**  
**Filter Performance**

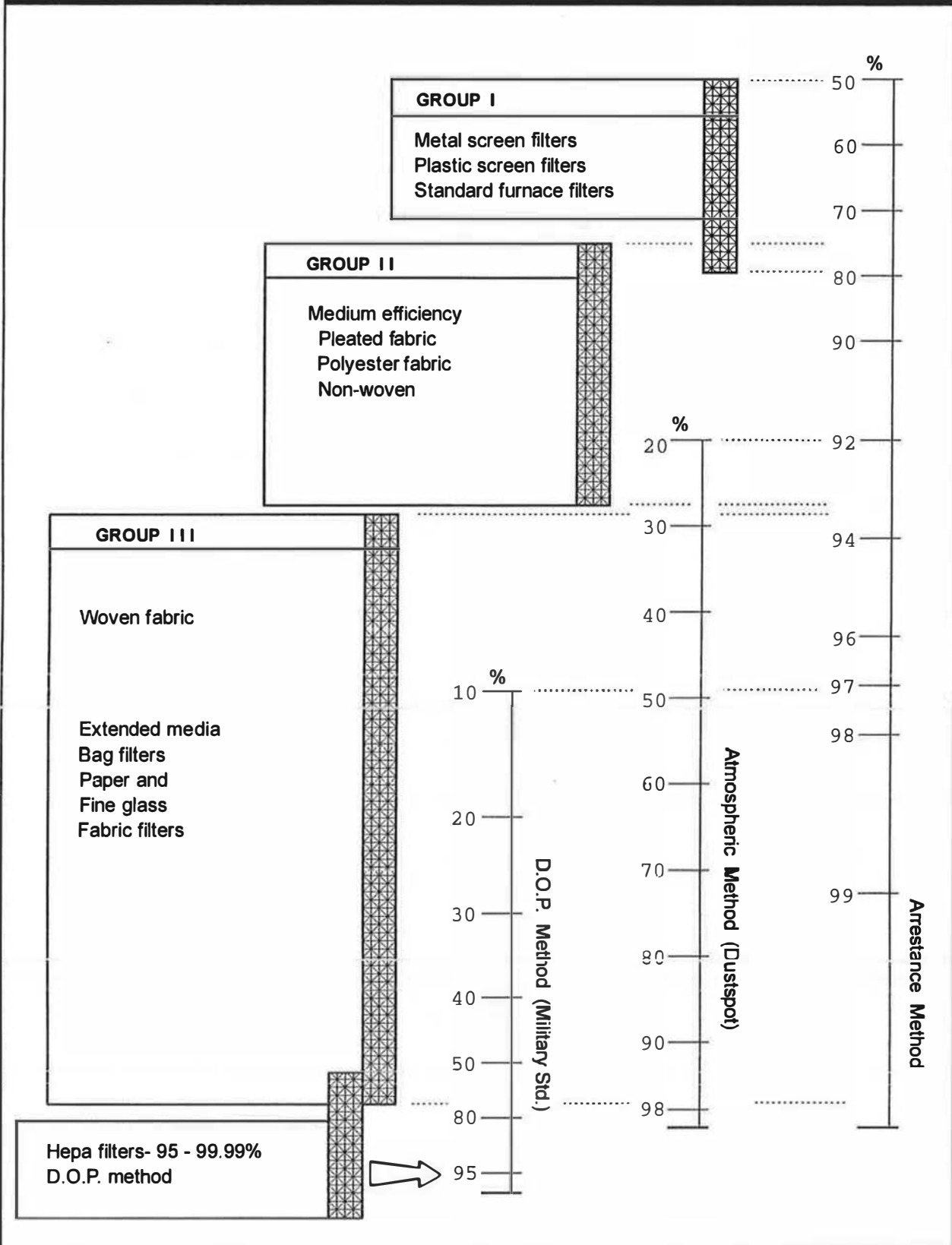

It is best to observe the manufacturer's recommended replacement schedule for this equipment.

## Other Special Considerations for the Environmentally Hypersensitive

### Filter materials and coatings

*The environmentally hypersensitive may wish to be very cautious about the type of material they choose for a particulate filter. Some fabrics and fibres may have a slight odour or release small amounts of dust or other gases.*

The most common materials for low- and medium-efficiency filters are polyester or spun glass mats or fabrics. These are generally made with small amounts of resin binders to hold them together and they may be coated with oily or sticky materials to make them more effective. (See the discussion of filter coatings in this chapter.) The fibres themselves are generally not odorous, but glass fibres may release irritating particles when handled. *For those few who may be affected by these materials, polyester-cotton blends or all-cotton fabric filters are also available in medium-efficiency types. Some high-efficiency filters are made from filter paper, or cellulose-glass paper blends, which usually are acceptable to the hypersensitive.* They are generally very pure materials with no coatings. These are often used in very high-performance, portable air filters, such as HEPA units.

Because new particulate filters are usually made from synthetic fibres which tend to be very slippery, and they may hold a small static charge which repels some particles, they are often coated at the factory with a sticky material which helps to catch dust. This is called a "tackifier," a viscous coating or sometimes an electret. The materials used are oils, waxy substances and some types of adhesives which do not harden. *These coatings do not present any problem to most people, but may produce a slight odour which is irritating to the hypersensitive, particularly when the filter is new. Filter suppliers should be able to tell their customers if their filters are coated,*

*and hypersensitive individuals can generally tell by smell if a filter is irritating to them.*

These coatings are most likely to be used on low-efficiency filters. They are unusual on medium- and higher-performance filters.

### Ozone

Ozone is created by the reaction of oxygen molecules in the presence of a strong electrical charge or ultraviolet light. Ozone has a very short life span, and breaks down into oxygen again within a few minutes of its creation. However, with a continuous source, it can be a serious problem in housing, particularly to those with respiratory problems.

The most common sources of ozone are outdoors from urban air pollution and electrical storms. Air pollution reacts in the presence of strong sunlight to form ozone and other hazardous gases. Ozone causes burning eyes and nose, shortness of breath and swelling of the soft tissues in the throat and bronchia. Asthmatics, and those with emphysema and other respiratory problems, can be acutely sensitive to ozone. However, it can also occur indoors if a faulty electronic air cleaner, open electric motor or other open sparks are present. Ozone is detectable by its very pungent odour, even at very low concentrations of a few parts per billion (ppb), but it also has the property of paralyzing the sense of smell very quickly in high concentrations, so there is only a very limited time available to detect it.

*Due to the risk of ozone, many hypersensitive people avoid electronic air cleaners.* Though the ozone risk is small from a new or newly cleaned unit, many older models produced excessive ozone and even new ones will do so if not properly cleaned and serviced. Open frame motors, such as those in many kitchen appliances and power tools, also produce ozone and should only be used with adequate ventilation by the hypersensitive.

Ozone is also sometimes used intentionally as a means of air cleaning and odour removal. For example, some air cleaners produce small

amounts of ozone which are intended to react with odours and neutralize them. Though it is well known that ozone has the ability to cause chemical changes in many air pollutants which will render them less potent, it is difficult to establish that ozone is an effective air treatment in occupied spaces. Though small amounts of ozone will reduce the apparent level of odours, this is partly due to the paralyzing effect ozone has on the nose. It is unlikely that ozone levels can be maintained at a high enough level in an occupied building to be effective for odour removal without causing health complaints.

In heavily contaminated buildings, such as those with smoke and water damage or fungus contamination, high-capacity ozone generators can be used temporarily for effective removal of lingering odours after clean-up. This method reduces odour levels, but its effectiveness in killing microbes is not known. It cannot be used while people or pets are present, because it must be used at very high concentrations which would injure them. It may also damage house plants, delicate fabrics, plastics, elastics and other reactive materials.

### **Ion balance**

Air contains gas molecules and particles that carry electrical charges. An electrically charged gas molecule is called an ion and its state can be described as negative, (carrying an excess of electrons) or positive (lacking electrons). In extreme conditions, such as during an electrical storm or near high-voltage electrical equipment, the altered state of air ionization is quite apparent and recognizable by the pungent odour of ozone.

However, more subtle states of air ionization probably also affect our perception of air quality and sense of well-being. Because air tends to lose its negative charges when it is contained within buildings or moved through metal ducts, it is well known that outdoor air contains more negative ions than indoor air. One theory suggests that the perception of altered ionization is one factor in complaints about stale air or stuffiness in buildings. Though this explanation is

controversial among air quality researchers, some manufacturers sell negative ion devices, as stand-alone units or as part of air cleaning equipment, and some people find that these improve perceived air quality.

Though ionization devices may be helpful to some people, it should be emphasized that they are not recommended for general use without careful assessment of risks, costs and other indoor air quality strategies.

### **Humidity control**

Control of indoor humidity has been discussed in Chapter 4, with emphasis on preventing extreme conditions which can lead to health risks. These risks normally occur at very low humidity levels which can cause respiratory irritation and high dust levels, or at very high humidity levels which support microbial growth, dust mites and the persistence of airborne bacteria and viruses.

The residential indoor air quality guidelines adopted by the Federal-Provincial Working Group on Indoor Air Quality recommend an optimum range of indoor humidity of from 30 to 55 per cent relative humidity in winter and 30 to 80 per cent in summer. This range is practical and achievable for most Canadians by adequate ventilation, occasional winter humidification and summer dehumidification during extreme weather.

Very low relative humidity can irritate sensitive respiratory tissue. It is best, where possible, to maintain humidity at about 45 per cent. Higher relative humidities support mildew growth and prolong the viable life of airborne bacteria, viruses and fungal spores. Good quality thermal windows, at least double-glazed, will be necessary to control condensation.

### **Dust mite control**

Dust mites are highly allergenic, microscopic insects which thrive in humid bedding, carpets and fabrics. They are one of the most prominent causes of dust allergy. Because dust mites thrive

in damp conditions, moisture control is one of the most effective methods of dust mite control. Air filtration is also important. Regular washing of all bed linens in hot (not warm) water and covering pillows, mattresses and box-springs in mite-proof or washable coverings is also recommended where dust allergy is a known problem. Mattresses and box springs should be vacuumed regularly.

### Central vacuums

A built-in vacuum can be an important part of an indoor air quality strategy. Conventional portable vacuums release a great deal of dust while in use, partly due to the inability of the filter bag to contain fine particles, and partly due to the disturbance of the dust in the room. Furthermore, the motors in vacuums commonly produce ozone and oily odours when operated. Built-in vacuums can be very effective because the motor is usually powerful and the dust storage is remote from the user. Motorized cleaning heads are also available for some models which are driven by air pressure and do not contain electrical parts which can produce ozone or insulation odours.

*When planning for a built-in vacuum, the two primary concerns for the hypersensitive are locating the motor and dust storage unit outside of the occupied areas of the home, and connecting the motor exhaust duct to an outlet to the outdoors. Some people may also react to the PVC duct and solvent glue used for connecting the vacuum hose outlets, though this lasts only a short time. If this is a problem, it is possible to construct this part of the system with metal ducts with joints sealed with foil tape. Another option sometimes used by the hypersensitive, is to wrap exposed plastic ducts carefully with metal foil and seal with foil tape.*

In existing houses where a built-in vacuum is difficult to install, or where cost is prohibitive, there are very high-performance portable vacuums available which have some of the advantages of built-in systems. These may use very high-performance filters (HEPA

standard) to minimize the fine dust released by their use. Some models are designed to the exacting standards required for asbestos removal operations. With careful handling, these can be an important aid to dust removal when a built-in vacuum is not feasible.

### Noise

*Many hypersensitive people will have periods of acute noise sensitivity as part of their condition. This may affect sleep and even daily activity. It is extremely important to reduce noise from mechanical equipment for this reason. The common strategies employed are:*

- selecting high-quality, low-noise equipment;
- locating equipment as far as possible from bedrooms and other commonly occupied rooms;
- isolating equipment by using vibration-absorbing mounts and duct connectors etc.;
- sizing equipment so it need not run at full capacity; and
- controlling equipment so it runs only when needed, and only at the speed that is needed.

### Cleaning supply air where ambient conditions are poor

In some locations, the outdoor air is so contaminated, that a filtration system should be installed to clean the supply air. Often, the system will include filters in the ventilation air supply of the HRV which exceed the capacity of the standard filters supplied with the HRV. This is usually done with an auxiliary filter housing attached to the supply duct as it leaves the HRV before it leads to the supply air distribution network. The filter housing may include pleated fabric filters, electrostatic filters, charcoal filters and, possibly, specialized chemical scrubbers. The filter housing should always accommodate filters which are as large as is practical for the space, and the manufacturer of the HRV should be consulted regarding the restriction produced by the filters. Please note that if the outdoor air is heavily polluted only part of the time, a practical approach is to turn off the HRV during these times.

### Chlorine removal from tap water

Most public water supplies are chlorinated to prevent the spread of infectious organisms through water supplies. Chlorination, however, produces gases such as chloroform, which are volatile and become airborne. Though the obvious route of exposure is through drinking and cooking, it is also important to note that about half of a typical person's exposure to chlorine compounds is through inhalation of vapours and skin absorption while showering. Gases and other contaminants can be removed by a whole-house filtration unit containing activated carbon. Where the cost of installing such a unit is prohibitive, a high-capacity shower filter and kitchen filtration unit may be an acceptable alternative. See Chapter 7 for more details.

### Air Ionizers/Ozone Generators

- Electrically charged elements generate negative ions.
- An ultraviolet chamber or electrical discharge generates ozone.

#### Typical system applications

As a tabletop unit or part of a multi-stage air cleaner.

#### Installation considerations and options

Typically only portable units.

#### Health issues

##### *Advantages*

- Negative ions may enhance apparent freshness of air and can reduce suspended dust. Ozone will reduce odours of some gases. Effectiveness of both is controversial.

##### *Disadvantages*

- Ozone in the indoor air is not recommended.

### General comments

- Ionizers are sold for dust control. Effectiveness is uncertain.
- High potency ozone generators are often used for effective odour removal (i.e., after fire damage) but must be used in unoccupied buildings as high ozone levels are hazardous. Ozone can cause materials to deteriorate. *Some very sensitive individuals are adversely affected by very low levels of ozone.*
- *Use of ozone generators for cleaning the air is not recommended.*
- Greater reliance should be placed on removing the contaminants at the source.

### Maintenance requirements

Occasional cleaning.

### Operating cost/savings

Small electrical cost.

### Product sources

- Specialty filtration suppliers; and
- allergy product suppliers.

### Adsorption Air Filters

Charcoal granules in fabric pockets, metal trays or charcoal treated fabric. Zeolite in fabric pockets. Charcoal and zeolite trap gases by adsorption.

### Other common names

- Charcoal or activated charcoal;
- activated carbon;
- zeolite filters;
- odour removal filters; and
- adsorption media forced air heating systems and HRVs.

### Typical system applications

As second stage filters in air cleaners or metal trays, for odour removal or occasionally in furnaces, fan coils and HRVs.

### Installation considerations and options

- Most effective in recirculating air systems.
- Low airflow rate preferred.
- Charcoal source may be hardwoods, coconut shell or peat.
- Treated fabrics available for both particle and gas removal.
- Cannot be used in humid conditions.
- Should have effective particulate filter upstream and downstream.

### Health issues

#### Advantages

- Charcoal will trap many gases but is less effective for formaldehyde and other lightweight gases.
- Zeolites will trap ammonia and other alkalines (especially urine odours).
- Very useful for reducing household odours and odours from outdoors such as wood smoke.

#### Disadvantages

- Must be replaced before saturated, otherwise the contaminants can be re-emitted.
- Charcoal and zeolite replacement is based on odour or a schedule.
- Adsorption media are costly.
- Refilling trays or containers is tedious and generates dust.

### General comments

- *Source of charcoal may be important for the hypersensitive. Coconut shell is often tolerable.*
- Must be changed regularly and kept dry. Not for use in humid environments.
- *Also used in emergency filter masks for the hypersensitive.*

### Maintenance requirements

Regular filter changes.

### Operating cost/savings

Cost of replacement of disposable media.

### Product sources

- Specialty filter suppliers; and
- allergy product suppliers.

See also the information on portable air cleaners in this chapter.

### Built-in Vacuum

A large vacuum motor and filter bag are ducted to several wall outlets. The vacuum head or motorized carpet brush is plugged into one of these outlets.

### Other common names

Central vacuum.

### Typical system applications

As a new or retrofit vacuum system.

### Installation considerations and options

- Separate electrical circuit for central unit.
- Sixty millimetre (2 1/2 in.) diameter PVC duct to outlets.

- Vacuum exhaust can be ducted to outdoors.
- Air-powered carpet brush motor available.

#### Health issues

##### Advantages

- Minimizes fine dust stirred up by portable vacuums.
- Allergens which pass filter can be ducted outdoors.
- Vacuum motor can be located in isolation to reduce noise and motor odours.
- Air-powered carpet brush produces no motor odours.

##### Disadvantages

- *PVC duct and glue may not be tolerated by the hypersensitive. These can be sealed.*

#### General comments

A high-performance, portable vacuum using a HEPA final filter may be an acceptable alternative. These should meet asbestos removal standards.

#### Maintenance requirements

Periodic canister cleaning. (Note: allergic individuals should wear a filter mask when cleaning.)

#### Product sources

- Building contractors; and
- vacuum suppliers.

#### Electronic Air Filters

Electrically charged wire mesh traps fine dust by static attraction.

#### Other common names

Electrostatic precipitator.

#### Typical system applications

- Furnace filter upgrades.
- Portable room air cleaners.

#### Installation considerations and options

Requires continuous electrical supply, continuous fan operation and adequate space for installation. Airflowing into the filter should be smooth and unobstructed.

#### Health issues

##### Advantages

- Very effective for fine dust and smoke particle removal.

##### Disadvantages

- Produces small amounts of irritating ozone. *Caution is suggested particularly with asthmatics and the environmentally hypersensitive.*
- Installation in retrofits where there is inadequate length of duct to the filter unit, or where the unit is located next to a bend in the ducting, may contribute to higher ozone production.

#### General comments

- Must have appropriate airflow rate for proper function.
- Often noisy (popping or crackling sounds).
- If electrical charge is lost, particles will be released.



### **Maintenance requirements**

- Regular cleaning of mesh screens to prevent ozone.
- Monitoring to ensure electrical charge is not lost during operation.

### **Operating cost/savings**

Small electrical cost for operation.

### **Product sources**

- Heating and ventilation contractors; and
- specialty filtration suppliers.

### **Extended Media Filters**

- Pleated units are medium efficiency with moderate flow resistance, made from glass, polyester or cotton blend panels.
- Bags have moderately high efficiency and flow resistance, made from polyester or cotton blend.
- HEPA units are high efficiency with high flow resistance, made from compressed fibre fabric or paper.

### **Other common names**

- Fabric filters; and
- dust filters.

### **Typical system applications**

In furnaces, fan coils, HRVs and room air cleaners usually for removing coarse to medium particles.

### **Installation considerations and options**

- Pleated units can typically be retrofitted to furnaces or fan coils without modifications.
- Medium efficiency available with charcoal treatment for odour removal.

- Bag filters require extra filter housing and possibly stronger fans.
- HEPA can only be used with specially designed blower units.

### **Health issues**

#### *Advantages*

- Pleated units effectively remove pollen, fine dust, animal dander, etc.
- Bags remove fungi and smoke particles.
- HEPA units remove bacteria and very fine particles.

#### *Disadvantages*

- Airflow decreases as they become loaded.

### **General comments**

- Fan capacity must be adequate to overcome resistance.
- Avoid fungicide-treated filters.

### **Maintenance requirements**

Regular changes when loaded.

### **Operating cost/savings**

Cost of replacement units for disposable types.

### **Product sources**

- Heating and ventilation contractors;
- specialty air filtration suppliers; and
- allergy product suppliers.

### **Furnace Filter Upgrades**

Medium-performance particle filters (pleated fabric), electrostatic filters or charcoal odour removal filters. Minimum of 400 mm x 600 mm x 50 mm (16 in. x 24 in. x 2 in.).

#### **Other common names**

- Pleated filters;
- electrostatic filters; and
- charcoal filters.

#### **Typical system applications**

Additional filters for forced air systems.

#### **Installation considerations and options**

- Must be large enough to minimize restriction of airflow. Additional sheet metal work and possibly a larger fan may be necessary.
- Manufactured filter boxes are available to fit furnaces.

#### **Health issues**

##### *Advantages*

- Can remove some pollens, animal dander, fine dust and odours.
- A popular upgrade for forced air systems. Best if combined with a low-temperature heat exchanger.

#### **General comments**

- Filters in a recirculated airstream are more effective than in a one-time application (i.e., filtered HRV supply).
- High-performance filters are generally too restrictive for furnaces. A separate blower system is required.

#### **Maintenance requirements**

Regular filter replacement or cleaning (electrostatic units).

#### **Operating cost/savings**

- Increased fan energy cost.
- Electronic units use a small amount of electricity.
- Replacement cost of disposable filters.

#### **Product sources**

- Heating and sheet metal contractors; and
- specialty filter suppliers.

See also the information on the specific air filtration types in this chapter.

### **Passive Electrostatic Air Filters**

Permanently charged plastic mesh traps fine dust. Usually polypropylene filter mesh.

#### **Other common names**

- Permanent electrostatic filter; and
- electret filters.

#### **Typical system applications**

- Furnace retrofits.
- Occasionally in portable units and HRVs.

#### **Installation considerations and options**

- Typically will fit in standard furnace filter space.
- Continuous fan operation recommended.
- Twenty-five millimetre, 50 mm (1 in., 2 in.) thick and custom sizes available.

### **Health issues**

#### ***Advantages***

- Effective removal of medium-sized dust and some smoke particles.
- Often used instead of electronic units due to ozone concerns.

#### ***Disadvantages***

- Not as effective as electronic filters.
- Core layers of multi-layer washable filters are not easily cleaned.

#### **General comments**

- No noise, no operating costs and simple installation.
- Some fine dust still passes through.

#### **Maintenance requirements**

- Regular cleaning of mesh screens by vacuuming and washing filters that are washable.
- “Permanent” filters still need to be replaced after some time. Inspect the layers at the centre for staining.

#### **Operating cost/savings**

None.

#### **Product sources**

- Specialty filter suppliers; and
- allergy product suppliers.

### **Portable Air Cleaners**

A box with a fan and two or more filters.

### **Other common names**

Room air cleaners.

#### **Typical system applications**

For dust and odour removal in small, enclosed rooms or apartments.

#### **Installation considerations and options**

- Many filter configurations are available.
- Automobile units available.
- High-efficiency (HEPA) units available.
- Available in all metal construction, no plastics or rubber parts.
- Check that there are no parts made of particleboard or medium-density fibreboard (MDF).

### **Health issues**

#### ***Advantages***

- Can offer moderate benefits for dust and odour removal in small rooms. Not a substitute for source control and ventilation.
- Often used to improve air quality in apartments and houses when major changes are impractical.

#### ***Disadvantages***

- Limited ability to clean air in a large room.
- Noisy and generate heat.
- Motors and components may generate odours.

### **General comments**

- The largest practical capacity unit should be used.
- Some units are noisy.

### **Maintenance requirements**

Occasional filter changes and cleaning.

### **Product sources**

- Specialty air cleaning suppliers; and
- allergy product suppliers.

See also the information on specific filter types in this chapter.

### **Reactive Gas Scrubbers**

Typically activated alumina impregnated with potassium permanganate, sodium hydroxide and other agents. Gases are trapped then broken down (oxidized by the permanganate; acids are neutralized by sodium hydroxide).

### **Other common names**

- Absorption filters;
- activated alumina filters; and
- permanganate filters.

### **Typical system applications**

As second or third stage filters in air cleaners for odour removal.

### **Installation considerations and options**

- Used for cleaning recirculated air.
- Effective for scrubbing incoming fresh air.
- Low airflow rate preferred.
- Should be protected by particulate filters upstream and downstream.

### **Health issues**

#### ***Advantages***

- Permanganate units will break down formaldehyde, hydrogen sulphide, natural gas odours, chlorine and other gases.
- Activated alumina with potassium permanganate have built-in indicators. Pink pellets turn brown to the core when spent.
- Alkaline units will neutralize acids, chlorine, bromine and fluorine.

#### ***Disadvantages***

- Media are costly.
- Refilling is dusty and tedious.

### **General comments**

- *A common element in multistage air cleaners for the hypersensitive.*
- More effective than charcoal for formaldehyde and natural gas odours.

### **Maintenance requirements**

Regular filter changes. Effectiveness lost with age and use.

### **Operating cost/savings**

Cost of replacement of disposable media.

### **Product sources**

- Specialty filter suppliers; and
- allergy suppliers.

See also the information on portable air cleaners and vacuum equipment in this chapter.

## **Turbulent Flow Precipitators**

- Particles are separated from the airstream by turbulent airflow created by a fan.
- No filter media are needed.

### **Other common names**

TFP.

### **Typical system applications**

Installed in supply side of an HRV or in the return air plenum of forced air systems.

### **Health issues**

#### *Advantages*

- Does not produce ozone.
- Effectively removes particles to 0.1 micron.
- Low maintenance requirements.
- Performance does not depend on the loading.

### **General comments**

- Only a portion of the air (up to 135 cfm) passes through the TFP at a time. When large amounts of pollutants are introduced or generated in the house, it may take time to bring the levels down.
- *Sensitive individuals should test the unit.*

### **Maintenance requirements**

Clean collectors annually or more frequently depending on the amount of dust.

### **Operating cost/savings**

Some electrical cost.

### **Product sources**

One manufacturer in Canada through heating and ventilation contractors.

See also the information on table air cleaners and vacuum equipment in this chapter.

## 7. WATER TREATMENT

---

Concerns about the quality of rural and municipal water supplies are increasing. The quality of raw water supplied to municipal plants from surface sources has been declining for many years, particularly in the densely populated areas. This is mainly due to industrial and sewage discharges, land development and agricultural run-off. Many who rely on groundwater are now also faced with contamination from industrial waste and landfills. Home water treatment systems or bottled drinking water are now widely used.

However, not all water quality problems are created by human activity. Excessive hardness (mineral content), metal and salt content, and hydrogen sulphide are some of the common, naturally occurring problems. Only a few are lucky enough to live in locations where they receive very pure water from wells and springs which requires no treatment at all.

One of the first principles of successful water treatment is to determine what may be necessary. Water contaminants must be identified, and the treatment specifically designed for the conditions. Fortunately, unlike air quality problems which can be very difficult to identify by testing, water quality testing is a relatively simple and inexpensive procedure. A basic water test for coliform bacteria, minerals, metals and salt is routine and costs about \$25 to \$50. If you are on a municipal system, these tests are done periodically by the local water authority, and the results can be obtained from them. Tests for heavy metals, agricultural chemicals or industrial waste are more expensive and are done by special laboratories.

### Water Purification Systems and Equipment

There are two basic types of water purification systems: point-of-use systems and whole-house systems. The point-of-use system treats only the water at one location. It may treat the water as it

passes through the tap or shower, or deliver it to a small storage container and then to a special tap, usually installed in the kitchen. This tap is then used for drinking and cooking. The whole-house system treats potable water before it enters the home plumbing, and may treat all the water, or just the water that flows to the kitchen and bathrooms. There is usually no treatment done for water used for yard and garden, and often untreated water is used for toilets and washing.

Most water treatment systems can be retrofitted to existing plumbing almost as readily as they can be installed in new plumbing. The only exception is a whole-house treatment system which is intended to serve some plumbing fixtures and not others. This type of installation may require alteration to some of the supply pipes to separate these fixtures. Some systems also require an electrical supply and a drain for discharging wastewater which is diverted past the filters or used for filter backwashing. This should be considered when planning an installation.

### Types of water treatment

Each type of water treatment is designed for removal of specific contaminants.

#### *Sediment removal*

Sieve filters are most commonly used for this purpose. These are usually disposable cartridges made from polyester or mineral fibre fabric tightly woven around a plastic core. When water is forced through these, small particles are trapped in the fabric.

Sediment filters are effective for particles of about five microns and larger, and do not generally produce excessive restriction to water flow. They can be used in whole-house filters. They are effective for most sand, soil and clay particles, rust residue and other visible sediment. These should always be used where sediment is a common problem and to protect more delicate

filtration equipment, such as reverse osmosis units, from sediment blockage. Sediments are usually not a health risk unless they contain metals, industrial waste or soils from surface run-off which may carry bacteria.

### ***Mineral removal***

Hard water is a common problem in many parts of Canada, particularly where groundwater is drawn from limestone formations. Hardness is usually defined as an excess of calcium carbonate, though other minerals may be involved. Hardness is generally only a nuisance because it causes staining of fixtures, poor performance of soaps and plugging of pipes. Water softening is typically done by packaged softener systems using a tank containing an ion-exchange resin which attracts and traps the minerals. The tank is then periodically flushed with salt which removes the trapped minerals and restores the resin. Though high mineral content is not usually considered a health risk, the unavoidable salt residue introduced by the softener after replenishing may be a risk to those on low sodium diets.

### ***Sterilization***

Surface water or groundwater subject to contamination by sewage or animal waste has a high risk of carrying coliform bacteria and other disease-causing organisms, such as amoebae and giardia, in many areas in Canada. This risk is widely considered to be the major public health problem with water systems. Though municipal water is sterilized with chlorine, some rural systems and independent wells and springs may require in-home sterilization. The usual methods are ultraviolet light and ozone treatment, though chlorine is also sometimes used. Ultraviolet and ozone treatment use high-energy electron sources contained in a contact chamber to destroy organisms. An advantage of this system is that, unlike chlorination, the process leaves no hazardous and polluting residue in the water.

### ***Metal removal***

Water supplies occasionally contain quantities of metals, such as iron, which are a nuisance; more toxic metals are sometimes present. Treatment systems similar to water softeners may be used for removal of some metal, or specialized chemical methods may be used. Metal removal may be also accomplished by processes such as reverse osmosis. (See organic compound removal and salt removal below.) Generally, where serious metal problems are present, a treatment system is required, designed specifically for local conditions. In these circumstances, a water treatment consultant, familiar with local conditions, should be used.

### ***De-chlorinating***

Chlorination of water supplies results in residual chlorine and other by-products which many health authorities now believe are a potential health risk. The most common method of removal is an activated charcoal or carbon block system which must be periodically discarded. This is an effective method, whether used as a whole-house system or at point of use. The most important feature of an effective charcoal system is the quantity of charcoal contained in it, and how often it is replaced or recharged. Only systems with large volumes of charcoal are effective. However, once chlorine has been removed, water is again prone to microbial contamination. It should not be stored for lengthy periods, or a sterilization unit should be added. (See sterilization above.) Some carbon filters are impregnated with silver as a bactericide. The effectiveness or impact of silver on the water is not known.

### ***Salt removal***

Reverse osmosis systems are the most popular for salt removal. These units force water under pressure through a selective membrane. Most contaminants will not pass through the membrane.

The process is slow and often energy intensive, and a large storage tank is required for fresh water supply to the house. The process requires a continuous flow past the membrane to prevent it from clogging. The bypass flow water is discharged to a drain. Typically, at least five litres of water are flushed for each litre of purified water. The membrane should be examined visually on a regular basis (or conductivity tests taken) to determine how often the membranes have to be replaced. It may be possible to use the bypass water for non-potable purposes, e.g., toilet flushing.

### ***Distillation***

This process removes minerals, heavy metals, other inorganic contaminants and organic materials of low volatility. Bacteria and molds are unlikely to survive the boiling process. Distillation effectively removes inorganic substances. Volatile organic substances, however, can be carried over with the water vapour. Carbon filtration combined with distillation would remove both types of contaminants.

### ***Organic compound removal***

Reverse osmosis units may also be used for organic compound removal. Point-of-use filters using ceramic elements or distillers can also remove salt and some organic compounds effectively in selected faucets. Charcoal filtering may also be used for organic compound removal, but should be preceded by a reverse osmosis or ceramic filter if contamination is serious. Charcoal alone is not entirely effective and will become contaminated too quickly.

### ***Buffering***

In some situations, water is acidic due to its source, usually in watersheds with pine and fir forests and acidic soil. Acidic water will leach metals such as lead and copper from plumbing, and will cause staining of metal fixtures and reduced life for pipes. A whole-house buffering unit is usually a tank containing an alkaline material, such as ground limestone or sterilized

oyster shell, which will reduce the acidity of water. The alkaline buffer must be renewed periodically as it is consumed. Where acid water is a problem, these systems are effective for reducing copper and lead content and prolonging the life of fixtures and pipes. Often, the unit contains charcoal for removal of chlorine products. Very alkaline water usually has an excess of calcium carbonate and can be treated with water softeners.

### **Equipment Cost**

The least costly water treatment units are point-of-use charcoal filters such as countertop units, under-counter units or shower filters for chlorine removal. These are available for \$50 to \$200. The most important considerations are the amount of charcoal contained in the unit and the cost of charcoal replacement. The consumer should be cautious and note that very inexpensive, small disposable units are probably not very effective, and will cost more when their short lifespan is considered. At the same time, there are many overpriced charcoal units sold through questionable marketing schemes which require very costly charcoal replacement. The best charcoal units are reasonably priced and inexpensive to renew. Some are available from department stores and mail order services.

A more sophisticated point-of-use unit designed for the countertop often contains a reverse osmosis or ceramic filter, followed by a charcoal filter. These cost about \$300 to \$400. Countertop distillation units are available in a higher price range. An under-counter unit containing reverse osmosis and charcoal with a small storage tank costs about \$400 to \$500, including installation of a special tap on the sink top.

Whole-house filters vary widely in cost depending on the treatment requirements and capacity. A whole house charcoal unit for chlorine removal can be built on basic water softener hardware (without the softener resin) and will cost about \$1,400 installed. It may also contain a buffer if acidic water is a problem. Other whole-house systems for softening and metal removal



are in the same price range. A whole-house salt removal system or other specialized system, using a large reverse osmosis membrane and storage tanks, may cost several thousand dollars including pumps, tanks and wiring.

### Equipment Maintenance

All water treatment equipment requires periodic maintenance and replacement of disposable filters. This is particularly important with units using charcoal filters, because these will become contaminated over time and may support hazardous bacteria. Replacement of smaller sediment filters and charcoal units is necessary periodically and may cost from \$5 to \$40. Larger units may only require annual replacement. Reverse osmosis and ceramic elements will need occasional replacement, depending on what quantities of contaminants reach them. Reverse osmosis membranes and ceramic filters usually cost about \$50 to \$150 to replace.

It is always best to trust service of any sophisticated water treatment equipment to a qualified and reputable service contractor. Service can often be purchased for a reasonable annual fee. However, it is wise to do some careful consumer research before entering into an agreement with a water treatment company.

### Water Conservation

Water conservation measures, such as low-flow fixtures, low-flush toilets and a thoughtful conservation lifestyle, are always appropriate. This is even more true if water in the home has been treated by costly systems. Moderation of water use may permit a downsizing of water treatment equipment which will reduce initial cost of the system and ongoing costs of purchasing or pumping and heating water.

### Charcoal/Carbon Filter

Granular charcoal or compressed charcoal blocks provide millions of pores for trapping impurities.

### Other common names

- Odour filter;
- chlorine removal filter; and
- adsorption filter.

### Typical system applications

As a final stage in treatment systems before delivery of filtered water. It can be a small unit (point-of-use) or a whole-house unit for treating all the water supply.

### Installation considerations and options

- Requires slow flow-through rate for effectiveness.
- Charcoal source may be hardwoods, coconut shell or peat.
- Large vessels filled with granular charcoal should be backwashed periodically to prevent channeling which allows impurities to escape.
- Should be followed by a sterilization unit to prevent bacterial contamination.

### Health issues

#### Advantages

- Can effectively remove chlorine and other compounds caused by municipal chlorination.
- Can remove some sulphur and other odours.
- *The type of charcoal may determine the acceptability of the filters to hypersensitive individuals.*

#### Disadvantages

- Not a safe method of treating water with high concentrations of hazardous contents (solvents, agricultural chemicals, etc.).
- Poor maintenance or absence of a sterilizer can lead to microbial contamination.

- The contaminants can break through or be re-released when the charcoal is exhausted.

#### **General comments**

- Used charcoal may release contaminants.
- Filters must be changed regularly.
- Some units contain small amounts of silver to retard bacteria growth.

#### **Maintenance requirements**

Charcoal replacement as required. The need for replacement is usually gauged by taste.

#### **Operating cost/savings**

Cost of replacement media.

#### **Product sources**

Water filtration suppliers.

See also the information on whole-house filters, point-of-use filters and sterilization units in this chapter.

### **Distillation Equipment**

Tap water is heated by an electric element and condensed steam is collected for use.

#### **Other common names**

Water stills, distillers.

#### **Typical system applications**

- As a countertop unit with a storage vessel for treating cooking and drinking water.
- Occasionally as a built-in unit.

#### **Installation considerations and options**

- Countertop units approximately 250 mm x 400 mm x 250 mm (10 in. x 16 in. x 10 in.) in size.

- May require separate electrical circuit.
- Can be tapped into supply line for in-line continuous operation.
- Produce heat while operating.

#### **Health issues**

#### *Advantages*

- Very effective removal of most impurities including metals, minerals, bacteria and some organic compounds.
- Does not require pre-chlorination of water.
- One of the most desirable for well water purification.
- Compared to reverse osmosis, does not require a minimum water pressure.

#### *Disadvantages*

- Some volatile impurities such as chlorination by-products or volatile organic chemical contaminants are released to the air and can re-enter finished water. Ventilation should be provided over the distiller to remove chlorine or other gases, if the water supply is chlorinated.

#### **General comments**

- Can be used as a countertop unit for kitchen water, but may generate too much heat.
- The heat generated by the distiller can be used for drying clothes in a ventilated room.
- Water tastes flat.

#### **Maintenance requirements**

Regular flushing of boiling chamber and de-scaling as required.

### **Operating cost/savings**

High electrical usage.

### **Product sources**

- Water filtration suppliers; and
- allergy product suppliers.

See also the information on point-of-use filters in this chapter.

### **Membrane Filters**

- Reverse osmosis: water is forced through a semi-permeable membrane which prevents many impurities from passing through. Only a fraction of the water flowing through the membrane is purified.
- Ceramic: water is forced through a thin ceramic cylinder.
- Flow rate is slow (10 to 50 ml/min.) for small units.

### **Other common names**

- Reverse osmosis; and
- ceramic filters.

### **Typical system applications**

- As a second-stage filter in point-of-use systems, after sediment filtration.
- Often followed by a charcoal filter.

### **Installation considerations and options**

- Used in under-counter or countertop units.
- Both stainless steel and PVC plastic housings are available.
- Water-saver control is available.
- Pre-treatment of the water with chlorine reduces microbial growth on the filter.

### **Health issues**

#### *Advantages*

- Can remove salts, bacteria, fine sediment and, if it has a charcoal filter, some organic compounds including chlorination by-products.

#### *Disadvantages*

- Small molecules are not retained by membranes.
- Cannot remove all dissolved metals.
- Possibility of microbial contamination of the membrane.
- There is no easy way to tell when the membrane should be replaced.
- Reverse osmosis units operate with minimum water pressure requirements and may not be the best choice if the water pressure is low or fluctuates.
- Large volume of bypass water is wasted.

### **General comments**

Both are prone to clogging and should be protected by a sediment filter. Ceramic filters are very fragile. Note that large-scale, commercial reverse osmosis units are professionally serviced and maintained on a regular basis. Units installed in homes must be maintained by the owner.

### **Maintenance requirements**

- Occasional replacement. Pull out and visually examine the membrane for loading.
- Charcoal filter must be replaced regularly.
- Regular pre-filter replacement to protect membrane.

### **Operating cost/savings**

Replacement cost for membranes.

### **Product sources**

- Water filtration suppliers; and
- allergy product suppliers.

See also information on point-of-use filters, sediment filters and charcoal filters in this chapter.

### **Metal or Mineral Removal Filters**

A vessel containing an ion-exchange resin attracts minerals or metals. Collected minerals are occasionally flushed to a drain by an automatic backwash cycle using salt to renew the resin. Treated water is typically for domestic uses.

### **Other common names**

- Water softeners; and
- iron (or other metal) filters.

### **Typical system applications**

As whole-house filters for water with high mineral or metal content.

### **Installation considerations and options**

- Standard softeners are used for high mineral (calcium carbonate) content. Special units are available for specific metals (i.e., iron).
- A drain and electrical supply are required. A bypass line can be installed for a separate kitchen faucet.

### **Health issues**

#### ***Advantages***

- High mineral content is a nuisance, not a major health concern.
- Conditions water and reduces scaling or staining.

### ***Disadvantages***

- Softness may add salt to finished water. Caution for those on low sodium diets.
- Replenishing salt is a chore.

### **General comments**

Water bypasses without treatment during backwash cycle.

### **Maintenance requirements**

Occasional checks and periodic addition of salt.

### **Operating cost/savings**

Cost of salt.

### **Product sources**

- Water treatment suppliers; and
- water softener companies.

### **Point-of-Use Filters**

- Usually has two or more stages.
- Sediment filter removes particles to approximately five microns.
- Reverse osmosis or ceramic filter removes organic compounds, salts, bacteria and some metals.
- Charcoal filter removes chlorine and odours.
- A small storage vessel, often pressurized, is required.

### **Other common names**

- Countertop filters; and
- under-counter filters. (See also distillation equipment.)

### **Typical system applications**

For cooking and drinking water treatment.

### **Installation considerations and options**

- Reverse osmosis or ceramic/charcoal units require drain connection.
- Under-counter units require approximately a 500 mm x 300 mm x 150 mm (20 in. x 12 in. x 6 in.) space.
- Units with pressurized storage require an extra tap at sink.
- Sediment/charcoal units can use bypass valve on kitchen tap.

### **Health issues**

#### *Advantages*

- Various filter combinations can remove nearly all impurities.

#### *Disadvantages*

- Storage vessels should be made of stainless steel or glass. Rubber bladders may not be acceptable to some individuals.
- Poor maintenance leads to contamination.

### **General comments**

- Small charcoal filters which fasten on to taps or showers are not effective. Filters should contain sediment pre-filters and 750 g (1.5 lbs) of charcoal minimum.
- Reverse osmosis units discharge bypass water to drain. Water use can be reduced with automatic shutoff valve.

### **Maintenance requirements**

- Periodic filter and charcoal replacement.
- Periodic reverse osmosis or ceramic membrane replacement.

### **Operating cost/savings**

Replacement cost of filter or membrane.

### **Product sources**

- Specialty water filtration suppliers; and
- allergy product suppliers.

See also the information on the various filter types in this chapter.

### **Sediment Filters**

Disposable cartridges made from polyester fibre in metal or plastic (PVC) housings. Fibre mesh traps particles.

### **Other common names**

- Sieve filters; and
- particle filters.

### **Typical system applications**

As a pre-filter or whole-house sediment filter to protect other filters.

### **Installation considerations and options**

- Filters cause some flow restriction. The unit must be large enough for expected flow.
- Filters particles two to 10 microns in size.
- Can be used for whole-house or point-of-use systems.

### **Health issues**

#### *Advantages*

- Removes most sand, soil and clay particles which cause turbidity (cloudiness), though most particles are not health risks.
- Poor maintenance is indicated by poor flow.

### **Disadvantages**

- Cannot remove dissolved contaminants.

### **General comments**

Should be used as a pre-filter in any water treatment system to protect filter membranes and charcoal from clogging.

### **Maintenance requirements**

Periodic filter replacement as required.

### **Operating cost/savings**

Cost of replacing disposable filters.

### **Product sources**

- Plumbing contractors; and
- water filtration suppliers.

See also the information on whole-house and point-of-use filters in this chapter.

### **Sterilization Units**

- A powerful ultraviolet lamp in a contact chamber with water flowing slowly past.

OR

- An electronic ozone generator pumps ozone into a contact chamber. Water must be vented for a few minutes for ozone to disappear.

### **Other common names**

Ultraviolet or ozone treatment.

### **Typical system applications**

- For whole-house treatment where microbial contamination is a concern, i.e., rural water systems.
- Occasionally as a final stage in whole house treatment of municipal water to prevent contamination after chlorine removal.

### **Installation considerations and options**

- Requires separate electrical circuit and controls.
- May require storage tanks and pumps.
- Automatic self-cleaning available for UV lamps.

### **Health issues**

### **Advantages**

- Effectively destroys micro-organisms such as coliform, bacteria, amoeba and giardia.

### **Disadvantages**

- Ozone must be vented to outdoors, away from windows and ventilation intakes.

### **General comments**

Usually only used where water is contaminated by surface run-off. Can be used after charcoal filters to protect from bacterial contamination.

### **Maintenance requirements**

Ultraviolet contact units require regular lamp cleaning to prevent scum buildup.

### **Operating cost/savings**

Consumes moderate amounts of electricity.

### **Product sources**

Specialty water filtration suppliers.

See also the information on whole-house and charcoal filters in this chapter.

### **Whole-House Water Filtration**

Usually has two or more stages:

- sediment filter removes particles to approximately five microns;

- charcoal filter removes chlorine and odours;
- sterilizers (ultraviolet or ozone) to destroy bacteria; and
- buffers (alkaline materials) to neutralize acidity (if required).

**Other common names**

Point-of-entry filter.

**Typical system applications**

Filtration of all water to kitchen, baths and laundry. Garden taps are usually not filtered.

**Installation considerations and options**

- Requires connection at main water entrance.
- Requires floor space for tank.
- May require electrical outlet and drain.
- Some units may use reverse osmosis and storage for salt or metal removal.
- System design depends on water contaminants.

**Health issues**

**Advantages**

- Can minimize chlorine exposure in shower.
- Can remove many contaminants from natural causes, agriculture and industry.
- Popular system for those on city water. May also be used with a kitchen filter for drinking water.

**Disadvantages**

- Does not sterilize water.
- Poor maintenance leads to contamination.

**General comments**

Can be built around standard water softener hardware using charcoal and buffer (if necessary) in place of softener resin. Timer can be used for backwashing to preserve charcoal effectiveness.

**Maintenance requirements**

- Filter and charcoal replacement (based on manufacturer's recommendations).
- Buffer renewal.

**Operating cost/savings**

Cost of replacing disposable filters and media.

**Product sources**

Specialty water filtration suppliers.

See also the information on the various filter media types and on sterilization units in this chapter.

## SELECTED REFERENCES

---

- Bower, John. (1995). *Understanding Ventilation*. Indiana: The Healthy House Institute.
- CMHC (Canada Mortgage and Housing Corporation). (1998). *Guide to Ventilation Systems: Consumer Series*. Ottawa.
- . (1998). *The Clean Air Guide. How to Identify and Correct Indoor Air Quality Problems in Your Home*, rev. ed. Ottawa.
- . (1997). *Building Materials for the Environmentally Hypersensitive*, rev. ed. Ottawa.
- . (1997). *Towards Healthy House Renovations: Research on Trends and Practices Relating to Healthy Housing, Indoor Air Quality and Ventilation within the Residential Renovation Industry*. Ottawa.
- . (1996). *Optimizing Residential Forced Air HVAC Systems*. Ottawa.
- . (1995). *Combustion Gases in Your Home: Things You Should Know About Combustion Spillage*. Ottawa.
- . (1995). *Ventilation System for New and Existing Houses with Baseboard Heating*. Ottawa.
- . (1993). *Efficient and Effective Residential Air Handling Devices: Final Report*. Ottawa.
- . (nd). *Maintaining Your HRV*, About Your House series, No. 9. Ottawa.



**DEFINITIONS**

**APPENDIX A:**

### **Absorption**

Chemical agents can be used for collecting or neutralizing gases by reacting with them. This effect is used for air cleaning using materials such as potassium permanganate.

### **Adsorption**

Porous and rough surfaces are capable of collecting gases because gas molecules are trapped inside the microscopic matrix. This effect is used for air cleaning using materials such as activated charcoal.

### **Air Barriers**

An air barrier is designed to restrict the movement of air into insulated cavities. It may also incorporate a vapour diffusion retarder. The continuous air barrier consists of an assembly of building materials in the exterior floors, walls and ceilings that are joined together to minimize air movement through the building envelope. Its purpose is to limit the movement of moisture into insulated cavities and entry of pollutants into the house from outside and from materials in the insulation cavities. The Airtight Drywall Approach is a complete system of air-barrier and vapour diffusion retarder construction for new housing that uses drywall as the primary barrier component.

### **Backdrafting (Back Venting or Flue Gas Spillage)**

A conventional chimney serving a furnace, heater or fireplace depends on the buoyancy forces of warm combustion gases to carry them outside. This is a weak force and can easily be overcome by a strong exhaust fan in a house or by wind conditions, particularly when the chimney is cold. When this occurs, these hazardous gases enter the home, a situation called backdrafting, back venting or flue gas spillage.

### **Building Envelope**

The sum of the enclosing and weather resisting parts of a house are called the building envelope. It includes walls, floors, ceilings, roofs, windows, doors, insulation cavities, air barriers, vapour barriers and all of their component parts.

### **Conduction**

Conduction is heat transfer through solid materials. Heat is lost from your home in winter or gained in summer by this means. An example of conduction moving heat out of a home is a standard aluminum window frame or single sheet of glass which loses heat rapidly during cold weather.

### **Convection**

Convection is the transfer of heat by means of movement of a liquid or a gas such as air due to the changes in density at different temperatures. For example, when air is heated, it becomes less dense and is then pushed up by cold air around it. An example of natural convection is warm air rising in a room and collecting near the ceiling.

### **Electret**

A filter coating to increase its ability to trap dust. An electret may be a material which retains a static electrical charge.

### **Envelope Air Exchange**

Envelope air exchange is air entering and leaving through cracks and openings in the exterior parts of the house. This can provide random natural ventilation, and often also provides air for combustion appliances. It also accounts for about one third of the home's heat requirements and is an important cause of comfort complaints.

### **Exfiltration**

Exfiltration is the uncontrolled leakage of air out of a building.

### **Filtration**

Filtration is the removal of contaminants from air or water by use of mechanical, electronic or chemical devices. Air filters may be designed to remove particles, gases and odours.

### **High Efficiency Particulate Air Filter (HEPA)**

A designation for very high-performance air filters capable of trapping very small particles such as the size of bacteria.

### **Indoor Air Quality**

Appropriate indoor air quality is defined as the absence of air contaminants which may impair the comfort or health of building occupants. Clearly this is a relative condition, because perfectly clean air free of all contaminants is difficult to achieve. In this report, indoor air quality refers to the absence of pollutants which can affect the health of typical occupants. Reference is also made to the extremely rigorous air quality conditions required by the environmentally hypersensitive.

### **Mechanical Ventilation (Forced Air)**

Mechanical ventilation is the introduction of outdoor air and extraction of indoor air by fan-operated equipment. It is largely independent of temperature or wind conditions. Typical examples are exhaust fans in kitchens and bathrooms, and heat-recovery ventilators providing supply and exhaust air. Fan-driven recirculation of indoor air for heating, cooling or air cleaning purposes by a furnace or air handler is not the same as ventilation.

### **Natural Ventilation**

Natural ventilation is air change provided by opening windows, stack action or air leakage through the building envelope without mechanical means such as fans. Natural ventilation needs a driving force, such as temperature differences between various parts of the house or air pressure differences caused by wind.

### **Radiation**

Radiation is the movement of heat by electromagnetic wave energy. It can move through empty space. Any object that is warmer than the objects around it will radiate heat to them. An example of radiation is the transfer of heat from the sun to the earth.

### **Recirculation**

Recirculation is the movement of air inside the building without intentional exchange with outdoor air. Recirculation is typically done to mix and distribute heated or cooled air, as well as to filter, humidify and dehumidify it. Recirculation improves the distribution of air, but is not a form of ventilation.

### **Relative Humidity**

Relative humidity (RH) is a measure of the moisture content of air compared to the maximum amount of moisture which the air could carry at that temperature. Relative humidity is expressed as a percentage, with 100 per cent RH indicating air which is fully saturated with moisture. RH is an important factor in comfort and air quality.

### **Scrubber**

A device for removing gases from an airstream. Usually contains adsorption and absorption filter materials.

### **Static Pressure**

Fans moving air, or pumps moving liquid must be capable of overcoming the resistance to flow created by restrictions in equipment, ducts and piping. This resistance is called static pressure loss and is measured as a resistance pressure generated at a given flow rate. This is an important design consideration when choosing fans, pumps, filters, ducts, piping and other equipment, which must provide sufficient static pressure at the required flow rate to overcome losses.

### **Supply Air**

Air supplied to the inhabited rooms through ducts, from a fan in a mechanical device such as a furnace, air handler or air conditioner. Usually a mix of recirculated and outdoor air.

### **Thermal Insulation**

Thermal insulation is a material which is a poor conductor of heat. Still air is a very good insulator because it has a low rate of heat conduction. Most insulations work by trapping air in foamed plastics, glass fibre, shredded paper (cellulose), mineral wool and expanded mineral materials.

### **Vapour Diffusion Retarder**

In addition to the moisture carried into building cavities by air movement, a small amount is also transferred by vapour diffusion. Because water vapour tends to move from a moist area to a dryer one, it can be forced through permeable materials such as wood and plaster. A diffusion retarder is a material, such as plastic film or a paint,

which resists moisture movement in the building envelope.

**Ventilation**

Ventilation is the removal of contaminated air from within the building and its replacement by outdoor air. This may be done by fan equipment, opening windows, by air leakage through the building envelope or a combination of these.

**HOW TO SELECT A  
MECHANICAL CONTRACTOR**

**APPENDIX B:**

## **Identifying a Contractor**

You can find heating contractors listed in the yellow pages or get referrals from people you know who have used contractors and have been satisfied with their services. You can also contact reputable builders in your area. They typically subcontract work to contractors who deliver good quality work. When you are choosing a mechanical contractor, these are some of the questions you should ask.

- Is the company an established firm?
- Does it provide a 24-hour emergency service?
- Are the personnel or staff appropriately trained or certified?

The Heating, Refrigerating and Air Conditioning Institute (HRAI) certifies individuals for residential ventilation installation, ventilating design and residential load calculation and duct design. Individuals who are certified by HRAI carry a wallet card bearing the certificate number and expiry date. HRAI publishes a list of certified persons, organized by city name. There are other certifications, usually provincial trade licensing requirements for working on gas, oil, electric or refrigeration-based systems.

An advantage of the HRAI certification is the complaint and arbitration process. This gives some level of assurance to consumers that if they are not satisfied with the certified person's work, they can appeal to the HRAI for investigation. If the certified person is found not to have followed the appropriate guidelines, he or she will be asked to set things right and if not, certification may be withdrawn.

It should be noted that many contractors use the services of outside designers who have the appropriate qualifications. A good contractor with the appropriate trade qualifications, who listens and works with an appropriately qualified designer/consultant will give as good a result as a contractor who holds all the qualifications. In

addition, the consumer has the advantage of relying on the consultant for independent advice.

- Does the company offer service contracts? The contractor should install the equipment and provide maintenance services.
- Can you get assurance of quality of equipment and service from the mechanical contractor? The contractor should be familiar with the history, frequency of repairs and maintenance requirements of the equipment. The contractor should be knowledgeable about the product and should be able to advise on its suitability based on your house characteristics, thermal insulation levels or compatibility with the existing system. You will be better off selecting contractors that promote the quality of their service and equipment at a reasonable rate rather than just low prices.
- Is the contractor approachable and willing to listen? You may have some requirements or preferences and you should be able to discuss these with the contractor. In situations where the homeowner is very sensitive, it is important that the client be able to discuss the requirements with the contractor. The client may have very specific requirements for materials to use or not to use, methods of installation or for the contractor to come to the job site free of cigarette smoke or other odours.
- Is the company in good standing with the Better Business Bureau? The Better Business Bureau maintains records of consumer complaints about its members.

## **Getting Estimates**

Arrange for the contractor to come and inspect the job site. Some small jobs may be priced out and an estimate written immediately, but larger jobs may require additional time to price properly and to prepare a heat loss and gain calculation for proper sizing of the equipment.

When comparing estimates, make sure they are written on proper forms that are easily read and understood. The work to be performed and the materials used should be of comparable quality, or make allowances for differences. Be sure the estimate includes the proper permits and licence. The warranty policy should be clearly stated for equipment, materials and labour. If the contractor uses subcontractors for some of the actual work, these should be listed in the proposal and in the contract.

### **The Contract**

The contract is the agreement between the homeowner and the contractor that specifies what work will be performed and gives a firm dollar value on that work. It is a legal binding document when signed by both parties, so be sure you agree with the contents before signing. Any changes or additions in the work to be done should never be made without those alterations being written into the contract and initialled by both parties.

In addition to the name, address and telephone number of the consumer and the contractor, the contract should clearly state the following items:

- required licences and permits will be purchased by the contractor;
- responsibility for removal of old equipment and materials;
- warranties and guarantees on materials and labour;
- approximate start and completion dates, unless specific dates and times are agreed upon;
- price and method of payment;
- provision of consumer orientation regarding operation and maintenance of equipment;
- provision of operation and maintenance manual to be left with the consumer; and
- any other specific requirements of the consumer.

### **Methods of Payment**

There is no standard method of payment, so this will vary from company to company. In any case, the payment schedule should be easy to understand and clearly state if interest charges are applicable. A normal deposit may be requested. Get a receipt for your deposit or have the amount shown on the contract and initialled by the salesman. All payments should be made directly to the company named in the contract.

### **Insurance**

It is important that the contractor and any subcontractors each have public liability and property damage insurance and be able to produce a certificate of good standing with the Workers' Compensation Board. You may wish to ask who the policy is with and follow up to verify its content.

The address for the Heating, Refrigerating and Air Conditioning Institute of Canada is:

HRAI  
300—5045 Orbitor Road  
Mississauga, Ontario L4W 4Y4





**MANUFACTURER AND SUPPLIER LISTINGS**

**APPENDIX C:**

**Listing of Manufacturers, Representatives, National Distributors  
by Equipment Category**

Furnaces (sealed combination)	101	Gas/propane	Carrier Suburban	Clare	Hunter	Lennox
	102	Oil	Clare			
	103	Electric	Carrier	Lennox	Chromalox	
Fan coil units	111	Heating	Aero First Suburban	Carrier GlowCore	Delhi Lennox	Energy Saving Mor-Flo
	112	Heating/cooling	Carrier Suburban	Enersol	First	Lennox
Heat pumps and air conditioning units	121	Central	Carrier	Clare	Enersol	Lennox
	122	Ground/water source	Canadian Geo-Solar	Lennox	Water Furnace	
	123	Water-water	WaterFurnace			
	124	Portable				
	125	Split unit	Carrier Lennox	Enersol Mitsubishi	Hitachi Sanyo	HydroTherm W.W.Grainger
	126	Water heating	Etech			
127	Evaporative cooling	Tradewinds				
128	Chillers	Enersol				
Convection heating	131	Electric	Fantech			
	132	Electric portable	De Longhi	Dimplex		
	133	Hydronic	Hydrotherm	W.W.Grainger		
Radiant heating	135	Electric	Convectaire-NMT	W.W.Grainger		
	136	Electric portable				
	137	Hydronic	Enersol	Radiant Technology	Wirsbo	
Passive solar heating	141					
Boilers (sealed combustion)	151	Gas/propane	GlowCore	HydroTherm	Mor-Flo	Trianco- Heatmaker
	152	Oil				
	153	Electric	Chromalox			
Hot water heaters (sealed combustion)	161	Gas/propane	GlowCore Mor-Flo	Lennox State	Trianco-Heatmaker	
	162	Oil				
	163	Electric				
	164	Solar	Solcan	Trianco-Heatmaker		
Heat exchangers (water)	165		Aero	DEC Therma Store	GlowCore	
Humidifiers	171	Steam	Dri-Steam Skuttle	E. L. Foust	Hoyme	Nortec
	172	Other	Carrier Nortec	E. L. Foust Research Products	Hoyme	Lennox
Accessories	181	Diffusers/grilles	Broan Kanalfakt	Conservation Energy Nutech	Eneready Venmar	Fantech W.W.Grainger
	182	Duct fittings	Broan Nutech	Dundas-Jafine Venmar	Eneready	Honeywell
	183	Flexible duct	Broan Nutech	Dundas-Jafine W.W.Grainger	Flexmaster	Flexible Technologies
	184	Tape	Dundas-Jafine	W.W.Grainger	Nashua	Polyken
	185	Duct sealant	Flexmaster			
	186	Insulation	Dundas-Jafine	Schuller		
Isolated fan motors	189	(TEAO, TENV, TEFC)	W.W. Grainger			

**Listing of Manufacturers, Representatives, National Distributors  
by Equipment Category (cont'd)**

<b>Packaged HVAC units</b>	191	Heating	B-K Metal	Lennox	Suburban	
	192	Ventilation	B-K Metal	Conservation Energy	Eden	
	193	Filtration	Dust Free	Eden		
	194	Air conditioning	B-K Metal	HydroTherm	Lennox	Suburban
<b>Ventilation</b>	201	Central exhaust fans	Airex (Aereco) Conservation Energy Kanalfakt	American Aldes Eden W.W.Grainger	Aston DEC Therna Store	Broan Fantech
	202	Exhaust fans	Broan Fantech	Continental Fan Kanalfakt	Eden Vent-Axia	Fan America W.W.Grainger
	203	Duct fans	Broan Eden	Conservation Energy Fantech	Continental Fan Kanalfakt	Delhi W.W.Grainger
	204	Kitchen range hoods	Broan W.W.Grainger	Eden	Fantech	Venmar
	210	Air Inlet devices	Aereco DEC Therna Store	American Aldes Eden	Conservation Energy Trol-A-Temp	Continental Fan
	211	Intake air filters	Eden	Nutech		
	220	Recirculating central ventilators	Eden	Nutech	Venmar	
	230	Heat recovery ventilators	AirXchange  Honeywell Venmar	Broan  Lennox	Conservation Energy  Nutech	Eden  Stirling
	240	Other heat recovery	DEC Therna Store	Etech		
	258	Make-up air units	Eden	Hoyme	Tibbits	Nutech
	280	Single room ventilators	AirXchange	Stirling		
270	Soll gas ventilation	Indoor Air Technologies				
<b>Air cleaners-portable</b>	311	HEPA	American Env. E. L. Foust	CenterCore Honeywell	Ecology Box N.E.E.D.S.	Eco-Sys Smiths
	312	Electrostatic	Eden	Honeywell	W.W.Grainger	
	313	Electronic	Dust Free	Eden	Honeywell	W.W.Grainger
	314	Other	Tibbits			
<b>Air Filters-HVAC</b>	321	Extended media	American Env. Environmental Filter Luwa Filter Smiths	BC Air Filter Farr N.E.E.D.S W.W.Grainger	Delhi Ecology Box General Filter Research Products	Eden E.L.Foust Honeywell Schuller
	322	Bag type	Eco-Air	Schuller	W.W.Grainger	
	323	HEPA	CenterCore Honeywell	Eco-Air Luwa Filter	Eco-Sys Schuller	E. L. Foust
	325	Electronic	Carrier	Honeywell	Lennox	W.W.Grainger
	328	Electrostatic	Allergy Relief W.W.Grainger	Dust Free	Honeywell	Newtron
<b>Adsorption media</b>	331	Activated charcoal	BC Air Filter Eco-Sys	Cameron-Yakima E. L. Foust	Columbus Tibbits	Dust Free
	332	Zeolites	BC Air Filter	Eco-Sys	Dust Free	
	333	Alumina/ permanganates	BC Air Filter	Dust Free	Eco-Sys	
<b>Scrubbers/scavengers</b>	341	Formaldehyde scavengers	E. L. Foust			
	342	Acid scrubbers	Dust Free			
	343	Other scrubbers	Dust Free Air Treatment			
	351	Ionization	Venmar	Allermed		
	352	Ozone				
	353	Other	Air Physlcs			
<b>Vacuum cleaners</b>	410	Built-in	Broan			
	420	Portable	Allergy Relief	Allermed	E. L. Foust	

**Listing of Manufacturers, Representatives, National Distributors  
by Equipment Category (cont'd)**

<b>Water treatment</b>	<b>510</b>	<b>Sediment</b>	American Env. General Ecology	Ametek-Plymouth N.E.E.D.S.	Ecology Box Smiths	E. L. Foust
	<b>520</b>	<b>Carbon/ charcoal</b>	American Env. E. L. Foust	Ametek-Plymouth General Ecology	Cameron-Yakima N.E.E.D.S.	Ecology Box Smiths
	<b>530</b>	<b>Membrane</b>	American Env.	Ecology Box	N.E.E.D.S.	Smiths
	<b>540</b>	<b>Diatillation</b>	American Env.	Ecology Box	N.E.E.D.S.	Smiths
	<b>550</b>	<b>Sterilization</b>	American Env.	Ecology Box	N.E.E.D.S.	Smiths
	<b>560</b>	<b>Reverse osmosis</b>	Ametek-Plymouth			
	<b>570</b>	<b>Metal/mineral removal</b>	Ametek-Plymouth	General Ecology		
	<b>580</b>	<b>Ion exchange resins</b>				

**Listing of Manufacturers, Representatives, National Distributors by Name**

**Aero Environmental Ltd.**  
1869 Sismet Rd.  
Cookeville, ON L4W 1W8  
Tel: (905) 238-0100  
Fax: (905) 238-0105  
165,111

**Air Physics Corporation**  
1 Northridge Plaza  
Winnetka, IL 60093  
Tel: (847) 446-4344  
353

**AirXchange Inc.**  
85 Longwater  
Rockland, MA 02370  
Tel: (781) 871-4816  
Fax: (781) 871-3029  
230,260

**Airex (Aereco)**  
123 Wendell Ave.  
Toronto, ON M9N 3K  
Tel: (416) 241-8667  
201,210

**Allergy Relief Products**  
9 Renata Court  
Dundas, ON L9H 6X1  
Tel: (905) 628-5324, 628-1734  
DIST,420,326

**American Aldes**  
4537 Northgate Ct.  
Sarasota, FL 34234  
Tel: (941) 351-3441  
201,210

**American Environmental Health Fdn.**  
8345 Walnut Hill Ln. #225  
Dallas, TX 75231  
Tel: (214) 361-9515  
Fax: (214) 691-8432  
DIST,311,321,510,521,541

**Allermed**  
31 Steel Rd.  
Wylie, TX 75098  
Tel: (972) 442-4898

**Ametek-Plymouth Products Div.**  
Box 1047  
Sheboygan, WI 53082  
Tel: (414) 457-9435  
Fax: (414) 457-6652  
510,520,560,570

**Aston Industries**  
50 Courchesne  
St.Leonard d'Aston, QC JOC 1M0  
Tel: (819) 399-2175  
201

**BC Air Filter**

2809 Norland Ave.  
Burnaby, BC V5B 3A9  
Tel: (604) 291-2554  
321,331,332

**Broan Canada Ltd.**

1140 Tistar Dr.  
Mississauga, ON L5T 1H9  
Tel: (905) 670-2500, 678-2251  
201,202,203,204,230,183,182,181,410

**B-K Metal Supplies Ltd.**

1050 Ellias St.  
London, ON N5W 3P6  
Tel: (519) 659-4666  
Fax: (519) 659-4683  
191,192,194

**Cameron-Yakima Inc.**

720 Valley Mall Boulevard  
Yakima, WA 98903  
Tel: (509) 452-6605  
Fax: (509) 453-9912  
331,520

**Canadian Geo-Solar**

640 Gartshore Rd.  
Fergus, ON N1M 2W8  
Tel: (519) 843-3393  
Fax: (519) 843-6944  
122

**Carrier Canada**

200-1900 Minnesota Court  
Mississauga, ON L5N 5R5  
Tel: (905) 826-9508  
Fax: (905) 826-2349  
101,103,111,112,121,125,172,325

**CentreCore Canada Inc.**

6725 Millcreek Dr.  
Mississauga, ON L5N 5V3  
Tel: (905) 542-7661  
Fax: (905) 542-7662  
311,323

**Clare Brothers Limited**

675 Davenport Road  
Kitchener, ON N2V 2E2  
Tel: (519) 725-1854  
101,102,121

**Columbus Industries**

2938 Rt 752  
Ashville, OH 43103  
Tel: (614) 983-2552  
331

**Conservation Energy Systems**

2525 Wentz Ave.  
Saskatoon, SK S7K 2K9  
Tel: (306) 242-3663  
Fax: (306) 242-3484  
201,203,210,230,192,181,182,183

**Continental Fan Mfg. Inc.**

205 Matheson Blvd. E.  
Cooksville, ON L4Z 3E3  
Tel: (905) 890-6887  
Fax: (905) 890-6193  
210,202,203

**Convectaire-NMT Inc.**

30 Place Sicard  
St-Therese, QC J7E 3X6  
Tel: (514) 433-5701, 434-3166  
135

**DeLonghi**

5425 Dixie Rd., Rm 201  
Mississauga, ON L4W 1E6  
Tel: (905) 238-1957  
132

**DEC Therma Store**

2001 Stoughton Road  
Madison, WI 53716  
Tel: (608) 222-5301  
201,240,165,210

**Delhi Industries Inc.**

83 Shaver  
Brantford, ON N4B 2Z3  
Tel: (519) 752-0311, 582-0581  
203,111,321

**Dri-Steem Humidifier Co.**  
14949 Technology Dr.  
Eden Prairie, MN 55344  
Tel: (612) 949-2415, 949-2933  
171

**Dundas-Jafine Inc.**  
80 West Dr.  
Brampton, ON L6T 3T6  
Tel: (905) 450-7200  
Fax: (905) 450-7207  
182,183,184,186

**Dust Free Inc.**  
1112 Industrial Dr.  
Royse City, TX 75189  
Tel: (972) 635-9564  
Fax: (972) 635-7972  
326,331,313,193

**Eco-Air Products Inc.**  
9455 Cabot Dr.  
San Diego, CA 92126  
Tel: (619) 271-8111  
Fax: (619) 578-8316  
322,323

**Eco-Sys Ltd.**  
2777C Innes Rd.  
Ottawa, ON K1B 3J7  
Tel: (613) 841-0190  
311,323,332,331,333

**Ecology Box**  
308 Oak Tree  
Clinton, MI 49236  
Tel: (517) 456-4188  
DIST,311,321,510,520,550

**Eden Energy Equipment**  
71 Wyndham St. S  
Guelph, ON N1E 5R3  
Tel: (519) 821-8478  
Fax: (519) 821-8491  
DIST,201,202,203,204,210,211,220,230,258,321,  
312,313,192,193

**Eneready Products Ltd.**  
6860 Antrim Ave.  
Burnaby, BC V5J 4M4  
Tel: (604) 433-5697  
Fax: (604) 438-8906  
DIST,181,182

**Energy Saving Products Ltd.**  
12615-124 Street  
Edmonton, AL T5L 0N8  
Tel: (403) 453-2093  
Fax: (403) 435-1932  
111

**Enersol Inc.**  
1655 de l'industrie  
Beloeil, QC J3G 4S5  
Tel: (514) 464-4545  
Fax: (514) 464-5563  
112,121,125,128.137

**Environmental Filter Corp.**  
265 Roberts Ave.  
Santa Rosa, CA 95407  
Tel: (707) 525-8633  
321

**Etech**  
3040 Holcomb Bridge Road NW  
Norcross, GA 30071  
Tel: (770) 825-0535  
240,126

**E.L. Foust Co. Inc.**  
Industrial Drive  
Elmhurst, IL 60126  
Tel: (630) 834-4952  
Fax: (630) 834-5341  
420,331,323,311,172,171,321,341,510,520

**Fan America Inc.**  
1748 Independence Blvd.  
Sarasota, FL 34234  
Tel: (941) 359-3616  
Fax: (941) 359-3523  
202

**Fantech Inc.**

1712 Northgate Blvd.  
Sarasota, FL 34234  
Tel: (941) 351-2947  
Fax: (941) 487-9951  
131,201,202,203,204,181

**Farr Co.**

2221 Park Place  
El Segundo, CA 90245  
Tel: (310) 536-0606  
321,323

**First Co.**

8273 Moberly Lane  
Dallas, TX 75227  
Tel: (214) 388-5751  
Fax: (214) 388-2255  
111,121

**Flexmaster Canada Ltd.**

20 West Pearce St.  
Thornhill, ON L4B 1E3  
Tel: (905) 731-9411  
Fax: (905) 731-7086  
183,185

**Flexible Technologies**

1630 Matheson Blvd.  
Cooksville, ON L4W 1Y4  
Tel: (905) 602-9660  
Fax: (905) 602-9665  
183

**General Ecology Inc.**

151 Sheree Blvd.  
Exton, PA 19341  
Tel: (620) 363-7900  
Fax: (620) 363-0412  
510,520,570

**General Filters Inc.**

43800 Grand River Ave.  
Novi, MI 48375  
Tel: (810) 349-2488  
Fax: (810) 349-2366  
321

**GlowCore Canada**

140 Sydney St. S.  
Kitchener, ON N2G 4J1  
Tel: (519) 571-0036  
Fax: (519) 579-5730  
151,161,165,111

**Hitachi (HSC) Canada Inc.**

6740 Capobello Rd.  
Streetsville, ON L5N 2L8  
Tel: (905) 821-4545  
125

**Honeywell Ltd.**

115 Gordon Baker Road  
Toronto, ON M2H 2N7  
Tel: (416) 502-5200  
182,230,311,312,313,321,325,326

**Hoyme Manufacturing Inc.**

3843 44th Ave.  
Camrose, AB T4V 3T1  
Tel: (403) 672-6553  
Fax: (403) 672-6554  
258,171,172

**Hunter Energy & Technologies Inc.**

100 Hunter Valley Rd.  
Orillia, ON L3V 1T4  
Tel: (705) 325-6111  
Fax: (705) 327-5658  
102,101

**HydroTherm Canada Corp.**

5211 Creebank  
Cooksville, ON L4W 1R3  
Tel: (905) 625-2991  
Fax: (905) 625-6610  
151,165,194,125

**Indoor Air Technologies Inc.**

2344 Haddington Crt.  
Ottawa, ON K1N 8J4  
Tel: (613) 731-2559  
Fax: (613) 731-2559  
270

**Kanalflakt Inc.**

50 Kanalflakt Way, P.O. Box 2000  
Bouctouche, NB E0A 1G0  
Tel: (506) 743-9500  
Fax: (506) 743-9600  
201,202,203,181

**Lennox Industries Canada Ltd.**

400 Norris Glen Rd.  
Etobicoke, ON M9C 1H5  
Tel: (416) 621-9302  
Fax: (416) 621-6303  
101,103,111,112,121,122,125,161,172,191,  
194,230,325

**Luwa Filter Corp.**

401 Hanks Ave.  
Aurora, IL 60505  
Tel: (630) 906-2100  
321,323

**Mitsubishi Electric Canada Inc.**

4299 Fourteenth  
Unionville, ON L3R 5G1  
Tel: (905) 475-7728  
Fax: (905) 475-7861  
125

**N.E.E.D.S.**

527 Charles Ave. 12A  
Syracuse, NY 13209  
Tel: (315) 488-6300  
Fax: (315) 488-6336  
DIST,311,321,510,520,540

**Newtron Products**

3874 Virginia Ave.  
Cincinnati, OH 45227  
Tel: (513) 561-7373  
326

**Nortec Air Conditioning Ind. Ltd.**

2740 Fenton Rd.  
Gloucester, ON K1T 3T7  
Tel: (613) 822-0335  
171,172

**Nutech Energy Systems Inc.**

511 McCormick Blvd.  
London, ON N5W 4C8  
Tel: (519) 457-1904  
Fax: (519) 457-1676  
181,182,183,211,220,230

**Radiant Technology Inc.**

11 Farber Drive  
Bellport, NY 11713  
Tel: (516) 286-0900, 286-0947  
137

**Research Products Corp.**

Box 1467  
Madison, WI 53701  
Tel: (608) 257-8801  
Fax: (608) 257-4357  
172,321

**Sanyo Canada Inc.**

50 Beth Neelson Drive  
Toronto, ON M4H 1M6  
Tel: (416) 421-8344  
Fax: (416) 421-8827  
125

**Schuller International Inc.**

Box 5108  
Denver, CO 80217  
Tel: (303) 978-2000  
186,321,322,323

**Skuttle Mfg. Co.**

Box 51  
Marietta, OH 45750  
Tel: (614) 373-9169, 373-9565  
171,172

**Smiths Pharmacy**

3463 Yonge St.  
Toronto, ON M2N 2N3  
Tel: (416) 488-2600  
Fax: (416) 484-8855  
DIST,311,321,510,520,530



**Solcan**

126 Wynchwood Park  
London, ON N6G 1R7  
Tel: (519) 473-0501  
164

**State Industries Inc.**

500 Bypass Rd.  
Ashland City, TN 37015  
Tel: (615) 792-4371  
161

**Stirling Technology Inc.**

Box 2633  
Athens, OH 45701  
Tel: (740) 594-2277  
Fax: (740) 594-1499  
230,260

**Suburban Distribution Ltd.**

3096 Devon Dr.  
Windsor, ON N8X 4L2  
Tel: (519) 969-1152  
101,111,112,191,194

**Tibbits Clean Air Machine Corp.**

Box 1016  
Cobourg, ON K9A 4W4  
Tel: (905) 372-7082  
Fax: (905) 372-8853  
314,321,331,258

**Tradewinds Technologies Inc.**

616 S. 55th Ave.  
Phoenix, AZ 85043  
Tel: (602) 278-1957  
Fax: (602) 272-9544  
127

**Trianco-Heatmaker**

111 York Ave.  
Randolph, MA 02368  
Tel: (617) 961-1660  
Fax: (617) 986-9907  
151,161,165

**Trol-A-Temp Ltd.**

55 Bushes Lane  
Elmwood Park, NJ 07407  
Tel: (201) 794-8004  
210

**Venmar Ventilation**

550 Lemire Boulevard  
Drummondville, QC J2C 7W9  
Tel: (819) 477-6226  
Fax: (819) 475-2660  
181,182,204,220,230,351

**W.W. Grainger Inc.**

50 McKesson Parkway  
Buffalo, NY 14225  
Tel: (716) 684-1000  
Fax: (716) 681-5334  
DIST,189,135,133,183,184,181,125,313,312,321,  
325,326,322,323,201,202,203,204

**Water-Furnace Inc.**

RR#1  
Mount Brydges, ON N8H 1P1  
Tel: (519) 264-1585  
122,123

**Wirsbo Company**

5925 148 St.W.  
Apple Valley, MN 55124  
Tel: (612) 891-2000  
Fax: (612) 891-2008  
137

