



Old Bracknell Lane West, Bracknell,
Berkshire, Great Britain RG12 4AH.
Tel: (0344) 53123

AIRBASE
N° 343
WTCB/CSTC

THIS PHOTOCOPY IS SENT TO YOU
FOR YOUR OWN PRIVATE STUDY
IN ACCORDANCE WITH
THE COPYRIGHT ACT

ENERGY EFFICIENT HOUSING - A PRAIRIE APPROACH

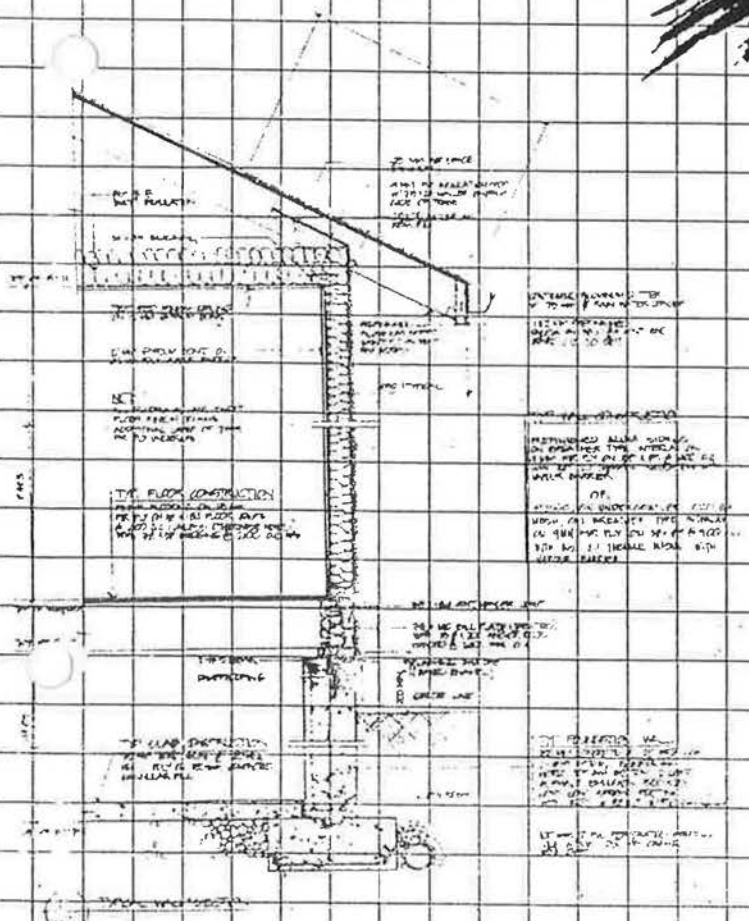
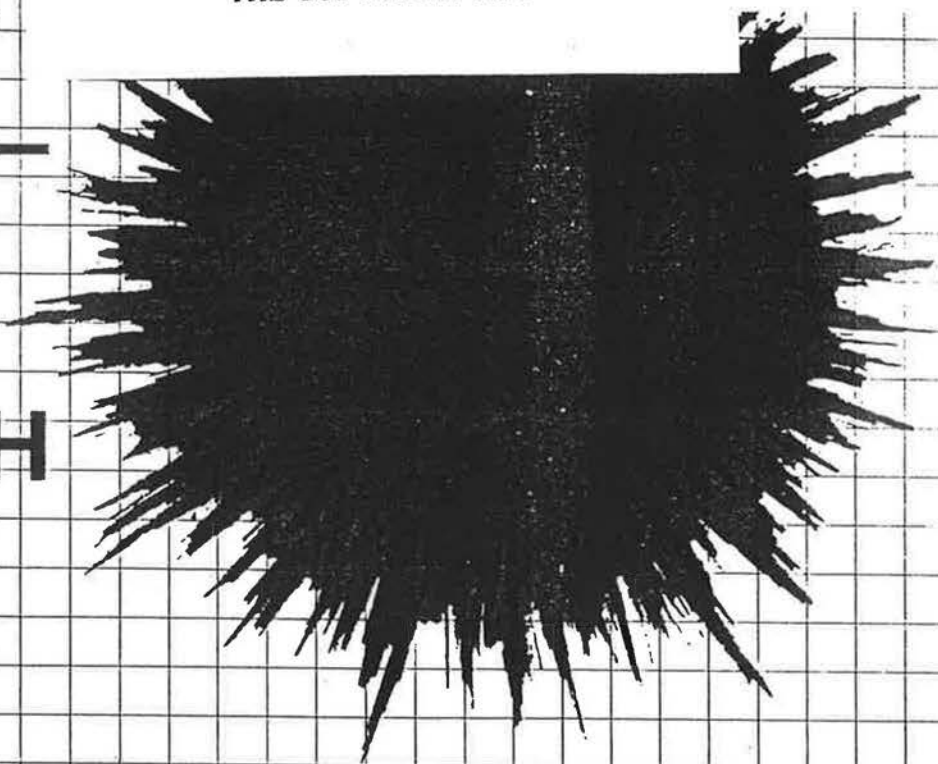

Alberta
ENERGY AND
NATURAL RESOURCES
Energy Conservation Branch

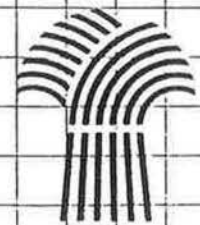

**Saskatchewan
Mineral Resources**
Office of Energy
Conservation

ENERGY EFFICIENT HOUSING A Prairie Approach

This publication is an updated reprint of the
Low Energy Passive Solar Housing Handbook

prepared by

Energy Research Development Group
Department of Mechanical Engineering
University of Saskatchewan

with assistance from

Division of Building Research
National Research Council
Saskatoon, Saskatchewan

and

Office of Energy Conservation
Saskatchewan Mineral
Resources

This publication is made available at no charge
by the governments of Alberta and Saskatchewan.
However, the views and opinions of the authors expressed herein
do not necessarily represent those of the respective provincial governments.

Additional copies of this booklet can be obtained from:

Energy Conservation Branch
Alberta Energy & Natural Resources
7th Floor, South Petroleum Plaza
9915 - 108 Street
Edmonton, Alberta
T5K 2C9

Office of Energy Conservation
Saskatchewan Mineral Resources
1914 Hamilton Street
Regina, Saskatchewan
S4P 4V4

ALBERTA
ENERGY AND NATURAL RESOURCES
ENERGY CONSERVATION BRANCH

SASKATCHEWAN
MINERAL RESOURCES
OFFICE OF ENERGY CONSERVATION

OCTOBER 1980

A number of studies have been carried out on the energy consumption of similar-sized families living in identical houses. Energy consumption rates of different families have varied by a factor of two. A family which lived in an energy-efficient house and refused to open and close shutters, did no regular upkeep on the house, insisted on leaving windows open in the winter, kept the house temperature at 27°C (80°F) year round, and so on, would most definitely **not** attain the low energy consumption figures stated in Figure 1. As with any energy-using device, some responsibility on the part of the user is required to attain a low energy consumption rate.

Conservation Measures for New Houses

2.1 Air Tightness

Most people now recognize the value of added insulation. The importance of air tightness in a home is not as well understood.

An average-sized new house contains about half a tonne (1100 lbs.) of air. Every two hours, the entire volume of the inside air is replaced by outside air. In winter conditions, this infiltration of outside air must be heated to keep the house warm.

In average homes, this air leakage is responsible for about one-third of the heating load or about 6 kW (20 000 BTU/hr.) when the outside temperature is -35° C. In an energy-efficient house, this amount of air leakage would be unacceptable. Ideally, a conservation house should be sealed as tightly as a hot air balloon - no leaks tolerated. To provide fresh air and to

remove moisture from the house, some other ventilation schemes, discussed in Section 2.1.4, are required.

A recent report by the National Research Council stated that in average homes the sources of air leakage (other than that associated with the furnace and chimney) were approximately as follows:

LOCATION OF AIR LEAKAGE IN AVERAGE HOMES

Exterior walls and basement (electrical and plumbing penetrations, connection between foundation and floor)	60%
Windows and doors	20%
Ceiling	20%

Open chimneys and fireplaces can also be a major path for air leakage. Typical leakage spots in standard houses are shown in Figure 2.

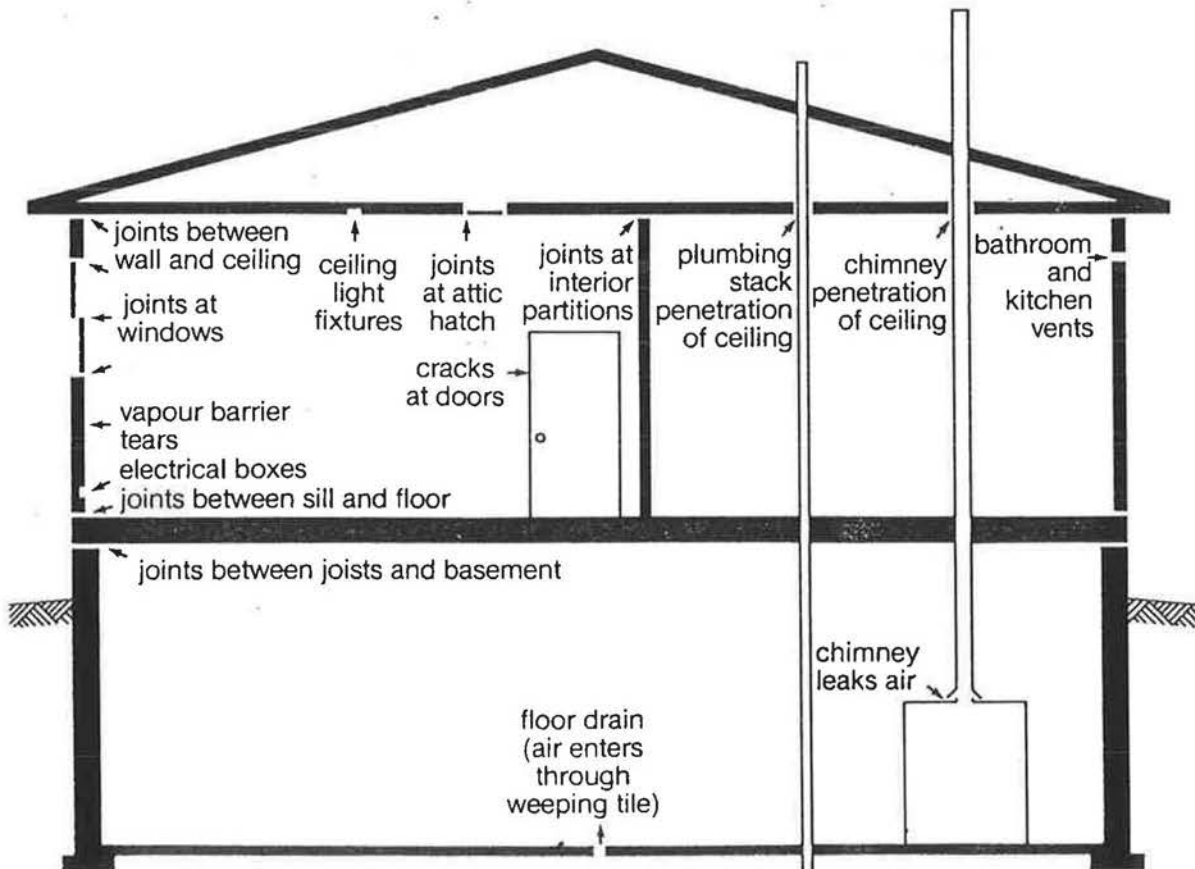

FIGURE 2. Air leakage spots in conventional housing

Table of Contents

1. INTRODUCTION	1
2. CONSERVATION MEASURES FOR NEW HOUSES	3
2.1 Air Tightness	3
2.1.1 Vapour Barrier	4
2.1.2 Windows	11
2.1.3 Doors	11
2.1.4 Ventilation and Dehumidification	12
2.1.5 Fuel Burning Apparatus	14
2.1.6 Exhaust Vents	15
2.2 Insulation	15
2.2.1 Recommended Levels	15
2.2.2 Construction Techniques	16
2.3 Passive Solar Gain	21
2.3.1 South-facing Windows	21
2.3.2 Heat Distribution	23
2.4 Use of Windows for Lighting	24
2.5 Insulating Window Systems	24
3. REFITTING AN OLDER HOUSE	25
4. WATER HEATING	27
4.1 Two-tank System	27
4.2 Low-cost Solar Panel Designs	27
5. ENERGY CONSERVATION IN ELECTRICITY USAGE	29
5.1 Choice of Appliances	29
6. INFORMATION SOURCES	31
6.1 House Construction - General	31
6.2 House Plans for Energy Conserving Houses	31
6.3 Shutter Idea Books	31
6.4 General Energy Construction	31
6.5 Solar Heating Information	31

Individuals planning houses or renovating existing houses should check with local authorities regarding building codes and bylaws prior to construction.

Introduction

Since 1973, the world has become particularly aware of the need to conserve energy. This booklet contains some practical measures that will allow you to conserve energy used within your house.

In Saskatchewan and Alberta we live in one of the coldest populated regions in the world, and the methods suggested here would not all be applicable in milder climates. However, the insulation levels used in this book would be suitable for buildings in the southern Canadian Prairies; thus, if you live in Edmonton or Winnipeg, the values suggested here are appropriate. In Vancouver, you could use less insulation; in Yellowknife, more. In any location where heating is required, however, the other information on energy conservation will be valid.

In Saskatchewan, the first true energy conservation house was built in 1977, and many of the recommendations that you find in this book are based on ideas incorporated in the Saskatchewan Conservation House.

One feature of the Saskatchewan Conservation House that we would **not** recommend at this time is an attempt to provide 100% solar heating. Complete reliance on active solar technology would seem to be uneconomical and ill-advised at present.

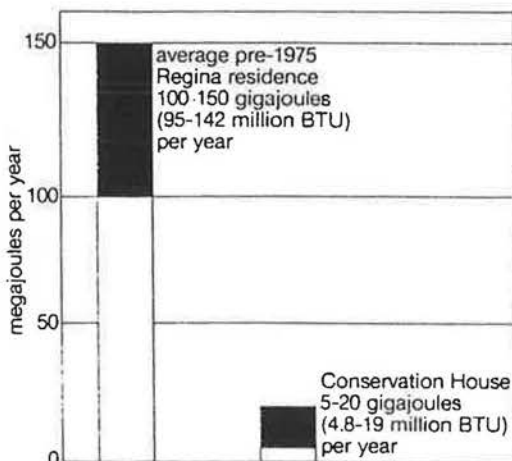

FIGURE 1. Annual space heating energy requirements

However, using the full energy conservation package suggested in this booklet, it is possible to reduce space heating requirements in an average-sized new home (100 m², 1075 sq. ft. plus basement) on the Prairies from average pre-1975 values of 150 - 200 GJ down to 20 GJ per year (190 million to 19 million BTU per year — see Figure 1).

This 90% energy-use reduction is achieved through only a handful of measures — air tightness, insulation, and shuttered south-facing windows.

To conserve energy for water heating in residences, water tanks and hot water lines can be insulated. A number of reasonable low-cost solar water heater designs are available commercially, but careful guidelines should be used in their selection.

Once space and water heating loads have been reduced, reduction in the use of electricity in the home is appropriate. Some suggestions along these lines are given in this booklet.

A relatively short booklet like this cannot do justice to the entire topic of house building. Perhaps the best — and certainly the cheapest — book on house construction is **Canadian Wood Frame House Construction**, which is available from Canada Mortgage and Housing Corporation (CMHC) for \$1.00.

With today's rapid inflation rates, it is difficult to put hard numbers on construction costs. As of 1979, however, there were builders in Saskatchewan producing energy-conserving homes incorporating the full range of conservation features (excluding the solar water heater) described in this booklet for about \$3 000 to \$4 000 extra on a new house of average size. On the other hand, prices of \$7 000 to \$10 000 extra have been quoted by some builders. As with any major purchase, one should shop around to find builders experienced in this area of energy-conserving houses. Those wishing to build a house by themselves could reduce costs, depending on the amount of do-it-yourself labour they provide.

An average new house has a leakage area equivalent to a single hole about 600mm (2 ft.) square. As the actual cracks are distributed throughout the house, we tend not to notice them. Some older homes have as much as four times this amount of leakage area. This air leakage accounts for approximately one-third of the total heat loss in an average dwelling.

In an energy-efficient house, one should try to reduce these leakage spots to zero and to provide ventilation air by other means.

Recommendations for new construction follow.

2.1.1 Vapour Barrier

The vapour barrier can be a crucial element in ensuring air tightness as well as vapour tightness in a building. Thus, in some parts of the world, the vapour barrier is referred to as an air-vapour barrier. The recommended vapour barrier for walls, ceiling, and floors is a 150 micrometre (6 mil) polyethylene sheet vapour barrier which is continuously sealed at all joints. The conventional vapour barrier as installed in most new houses is usually only 50 micrometres (2 mil) thick and is not thoroughly sealed.

The procedure for installing the vapour barrier is as follows:

- Staple 150 micrometre (6 mil) vapour barrier to studs and plates.
- Place bead of acoustical sealant over top of vapour barrier, ensuring that the sealant is continuous and in line with the wood.
- Overlap second barrier (always join the vapour barrier at a location where there exists a solid backing, such as wood).
- Cover vapour barrier with rigid material (plasterboard, wallboard, etc.)

All joints in the vapour barrier should be sealed with a durable sealant. A product that has proven successful is acoustical sealant, a type of modestly-priced, non-hardening material readily available in cartridges for caulking guns. Do **not** use a caulking material that will harden and peel away from the polyethylene and crack, as this will defeat the purpose of the caulking.

As shown in Figure 3, there are three essentials needed for a good vapour barrier seal —solid backing, continuous sealant and rigid covering material. The solid backing and rigid covering are necessary to withstand wind-

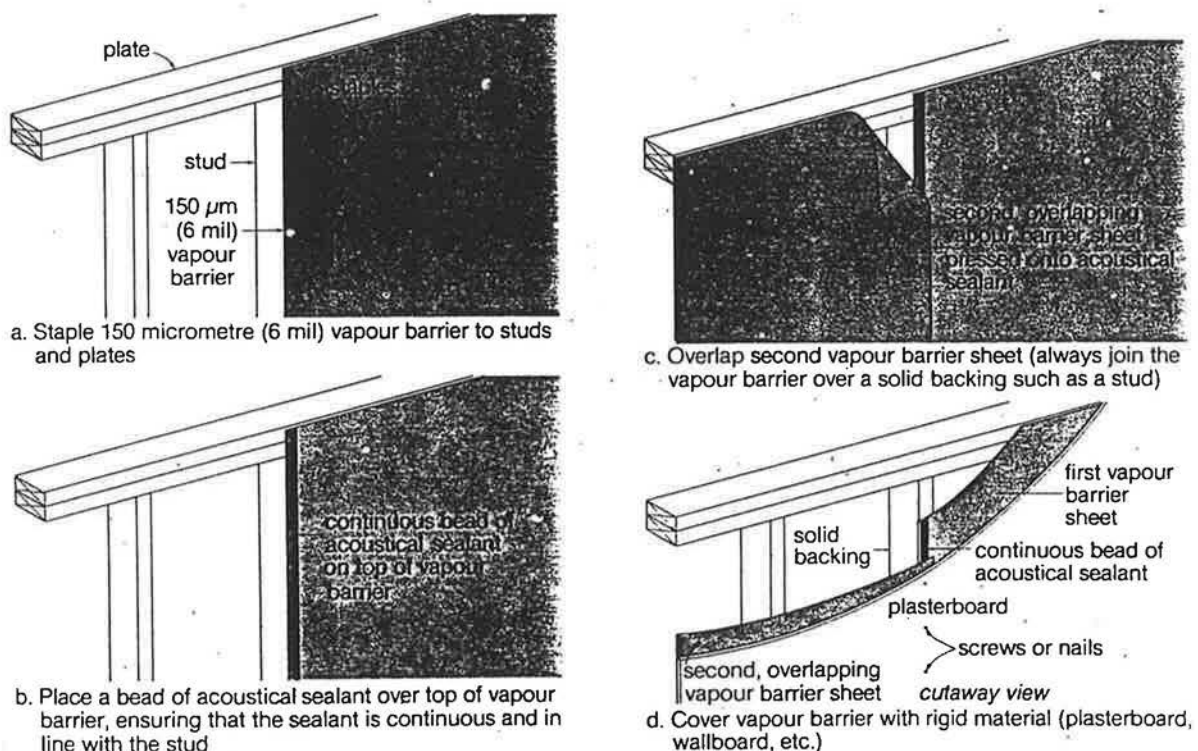

FIGURE 3. Technique for joining vapour barrier sheets on wall studs (insulation not shown)

forces which can pull the sheets apart. Proper vapour barrier installation is a crucial step for energy conservation, and the amount of discussion that we spend in this booklet on the vapour barrier is an indication of its importance.

Figure 4 shows a section through a wall of a house, indicating how the vapour barrier is made continuous between floors and continuous between the wall and ceiling. In conventional construction, large air leaks occur at these locations.

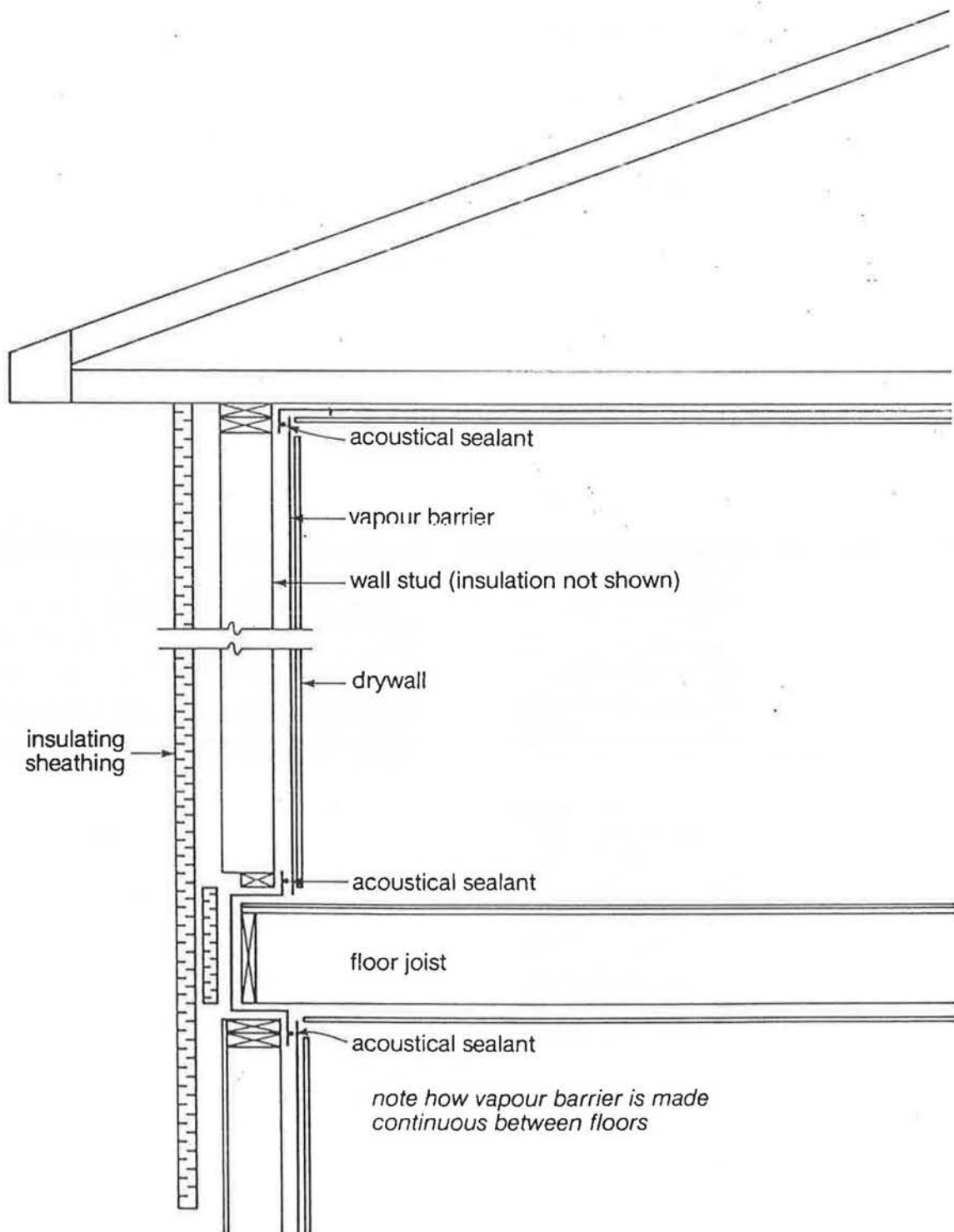

FIGURE 4. Wall section - vapour barrier detail

The approach of placing the vapour barrier on the inside, just beneath the wall and ceiling finish, as shown in Figure 4, has a number of drawbacks. First, extreme care must be taken to prevent the vapour barrier being punctured during construction. Second, electrical outlets must penetrate the vapour barrier unless surface wiring is used. Third, the drywall installers can ruin a vapour barrier job if they are not careful to avoid penetrating the vapour barrier with keyhole saws and to avoid breaking the seals on the sheets. Later in the booklet, an alternative technique for vapour barrier installation is discussed, which avoids some of these problems of vapour barrier penetration.

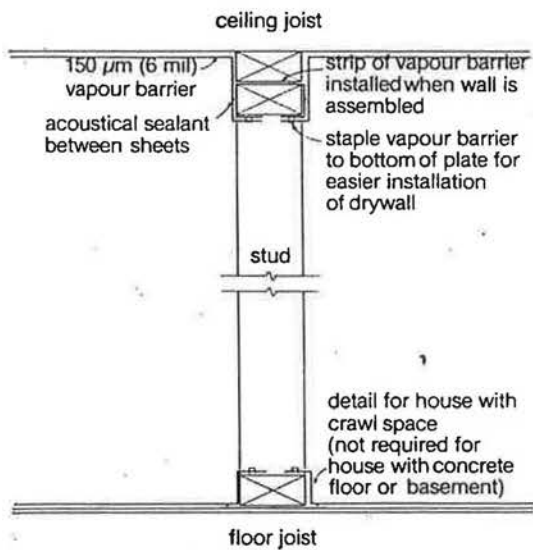

FIGURE 5. Vapour barrier installation for partition wall

Figure 5 shows a detail for installation of the vapour barrier at an interior partition. For some types of construction, it may be desirable to install the ceiling vapour barrier in a continuous sheet, install the ceiling finish, and then to erect the interior partitions, in order to have a continuous vapour barrier without a lot of caulking.

Figure 6 illustrates a technique for attaining a good vapour barrier seal around electrical outlets. Considerable care must be used with this technique to get a good seal. The work sequence should be as follows:

- install blocking
- staple vapour barrier pan

- drill hole through blocking to pass wire, caulk at pan
- wire electrical box
- fill pan with insulation
- provide bead of acoustical sealant around pan
- press wall vapour barrier into sealant
- cut hole in wall vapour barrier to pass electrical box.

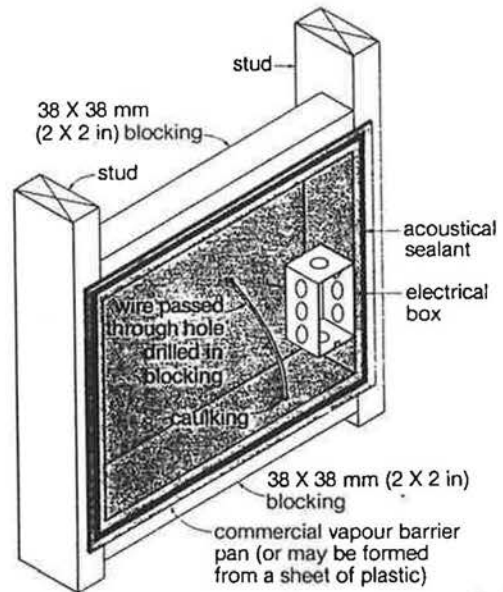

FIGURE 6. Vapour barrier installation around electrical box

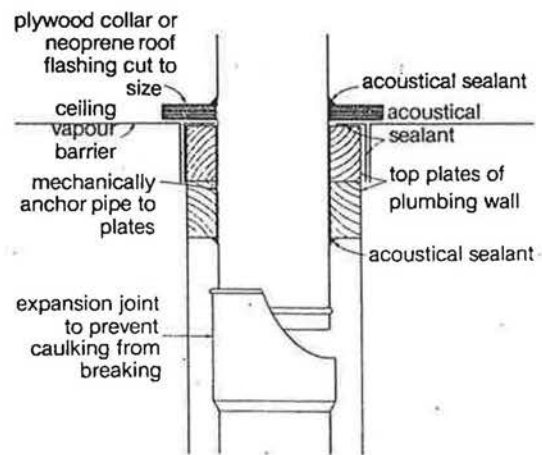

FIGURE 7. Vapour barrier installation around plumbing vent stack

Figure 7 illustrates a technique for the vapour barrier around a plumbing vent stack. The expansion joint is necessary, as plastic piping used in homes can expand and contract as much as 25 mm (1 in.) due to temperature changes.

Figure 8 shows a detail for the vapour barrier around a window. The use of a plywood liner for the window cavity is of value in walls that are not standard thickness.

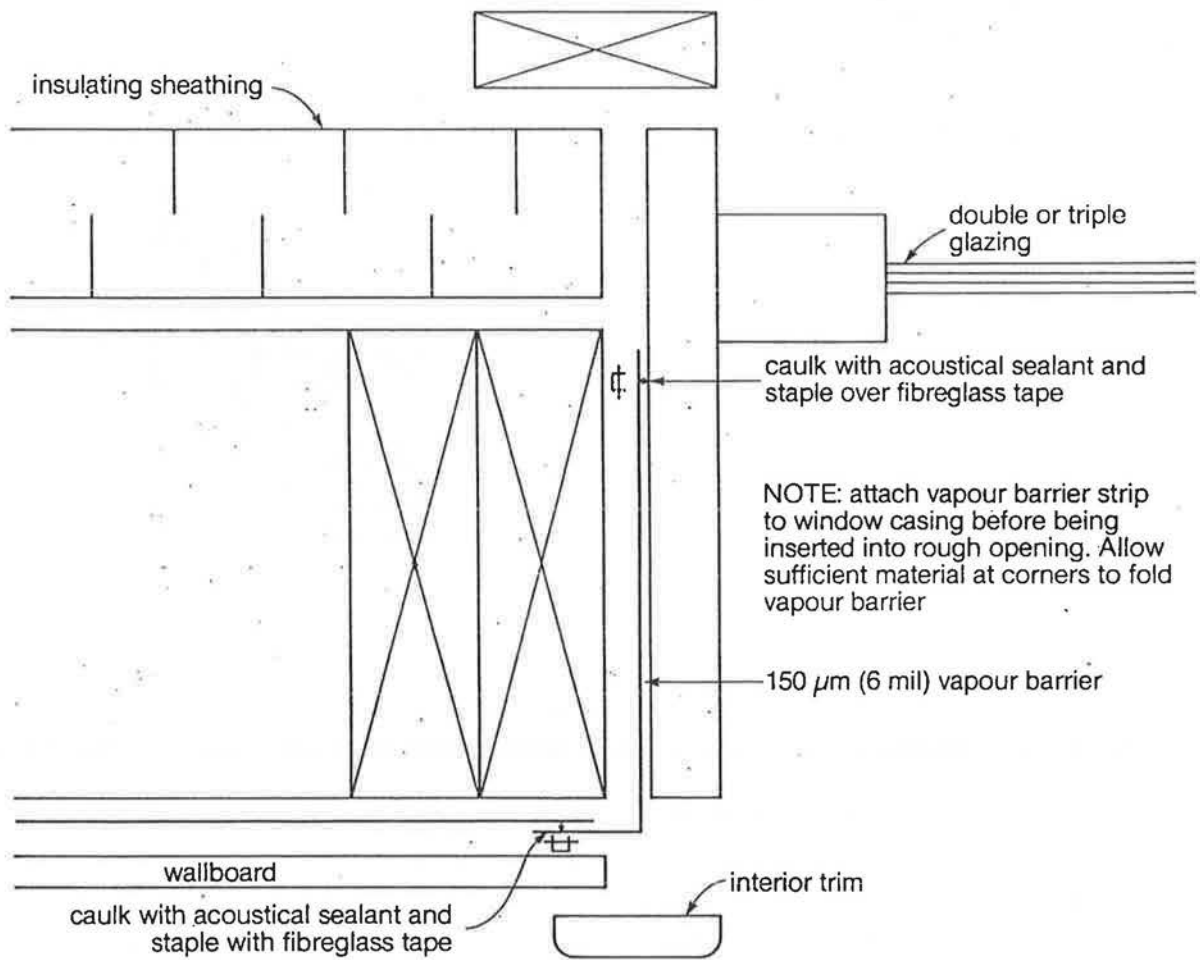

FIGURE 8. Vapour barrier installation at window

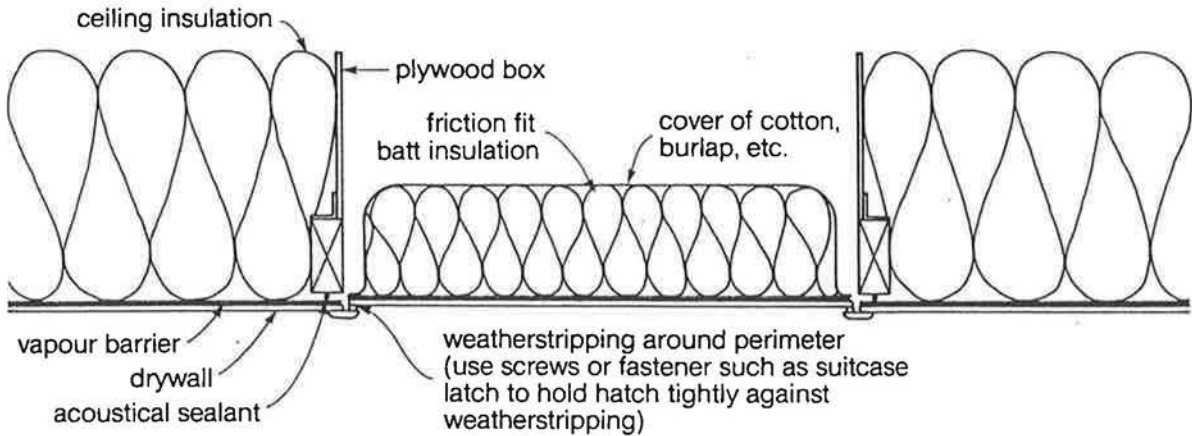

FIGURE 9. Attic hatch detail

Figure 9 shows a detail for the attic hatch. It would be far simpler to eliminate the interior attic hatch and put an opening into the attic from outside, such as in the gable end or via the garage. (A lock may be necessary.)

DOUBLE STUD WALL CONSTRUCTION

Double stud walls are useful for two reasons: first, they allow you to use large amounts of wall insulation using lower cost batt insulation while minimizing conduction through the studs; second, the vapour barrier may be placed away from the inside surface of the walls to protect it during construction and to minimize penetration by electrical wires and

plumbing. A rough rule of thumb for the Canadian Prairie climate is that you should have twice as much insulation outside the vapour barrier as inside to prevent condensation in the wall. Thus, with 90 mm (3½ in.) of insulation inside, a minimum of 180 mm (7 in.) should be used outside the vapour barrier.

In buildings with higher than normal humidity levels (laundries, swimming pools, etc.), it would be advisable to place the vapour barrier at the conventional location just outside the inner wall surface.

The construction sequence for a double stud wall is as follows (see Figure 10):

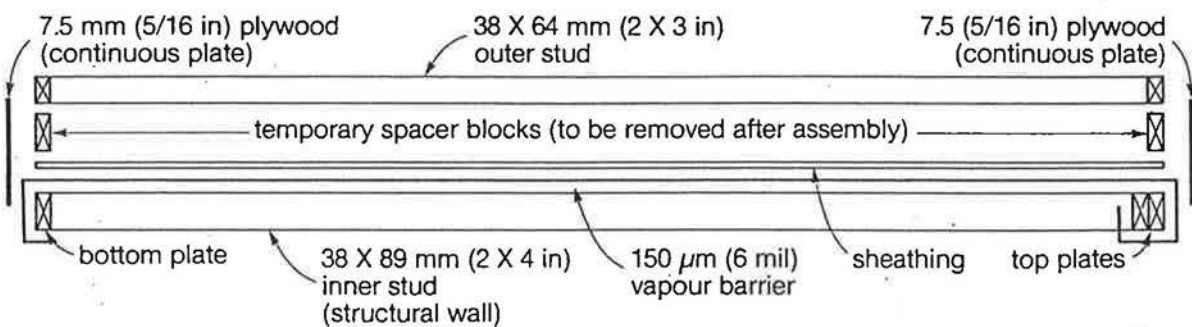

FIGURE 10. Double stud wall assembly

- Build the inner stud wall (this is the structural wall for the house) in conventional manner but include both top plates. Place 150 micrometre (6 mil) vapour barrier on top, then nail sheathing on in conventional manner. Take care not to damage the vapour barrier when cutting the sheathing.
- Build the outer stud wall on top of the inner wall. (To save time, mark plates for both the inner and outer walls at the same time.)
- Using temporary spacer blocks, nail the two walls together using the top and bottom plywood plates.

- Tilt wall section up and put in place. Staple vapour barrier flaps to inner face of top and bottom plates to prevent damage. The wall can now be wired and insulated when desired. Since the inner stud is on the inside of the vapour barrier, electrical wires may be run through the studs without penetrating the vapour barrier.

A number of details concerning corners, windows, vents, and split-level houses are shown in Figures 11 to 14. Vents for bathrooms, kitchens, etc. should not exhaust through the ceiling. Place the vents through the wall at ground level. Complete cross sections of walls are shown in Figures 23, 24, and 25.

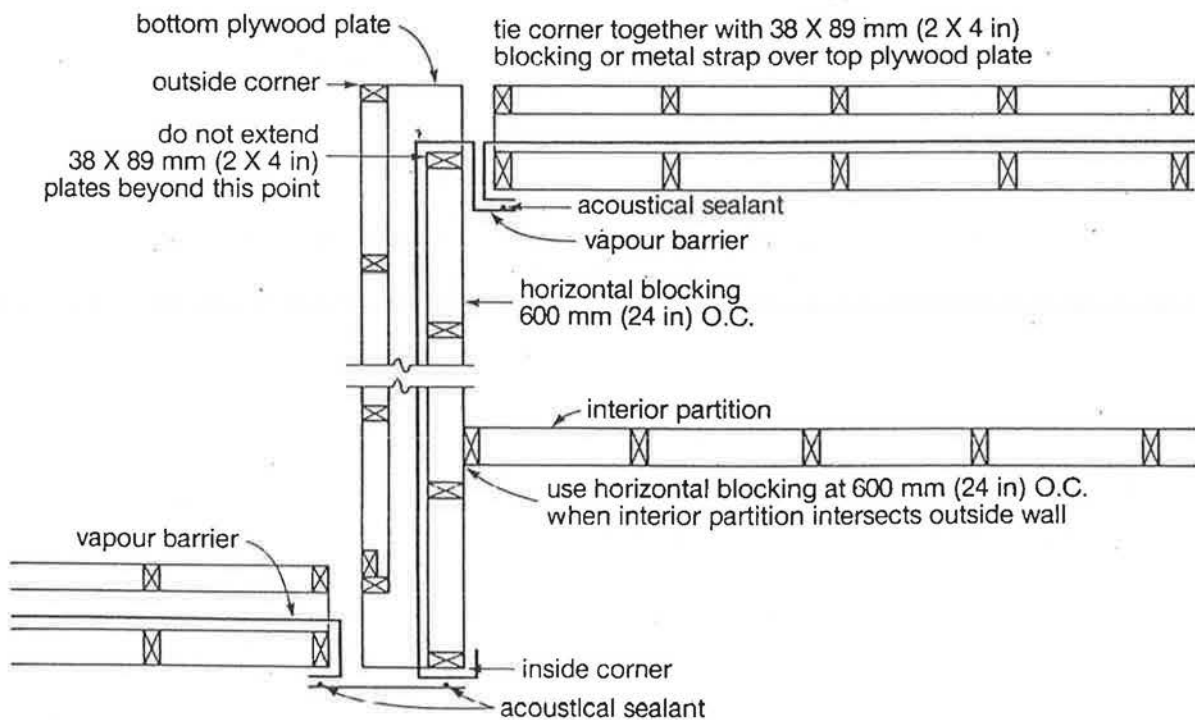

FIGURE 11. Double stud wall details

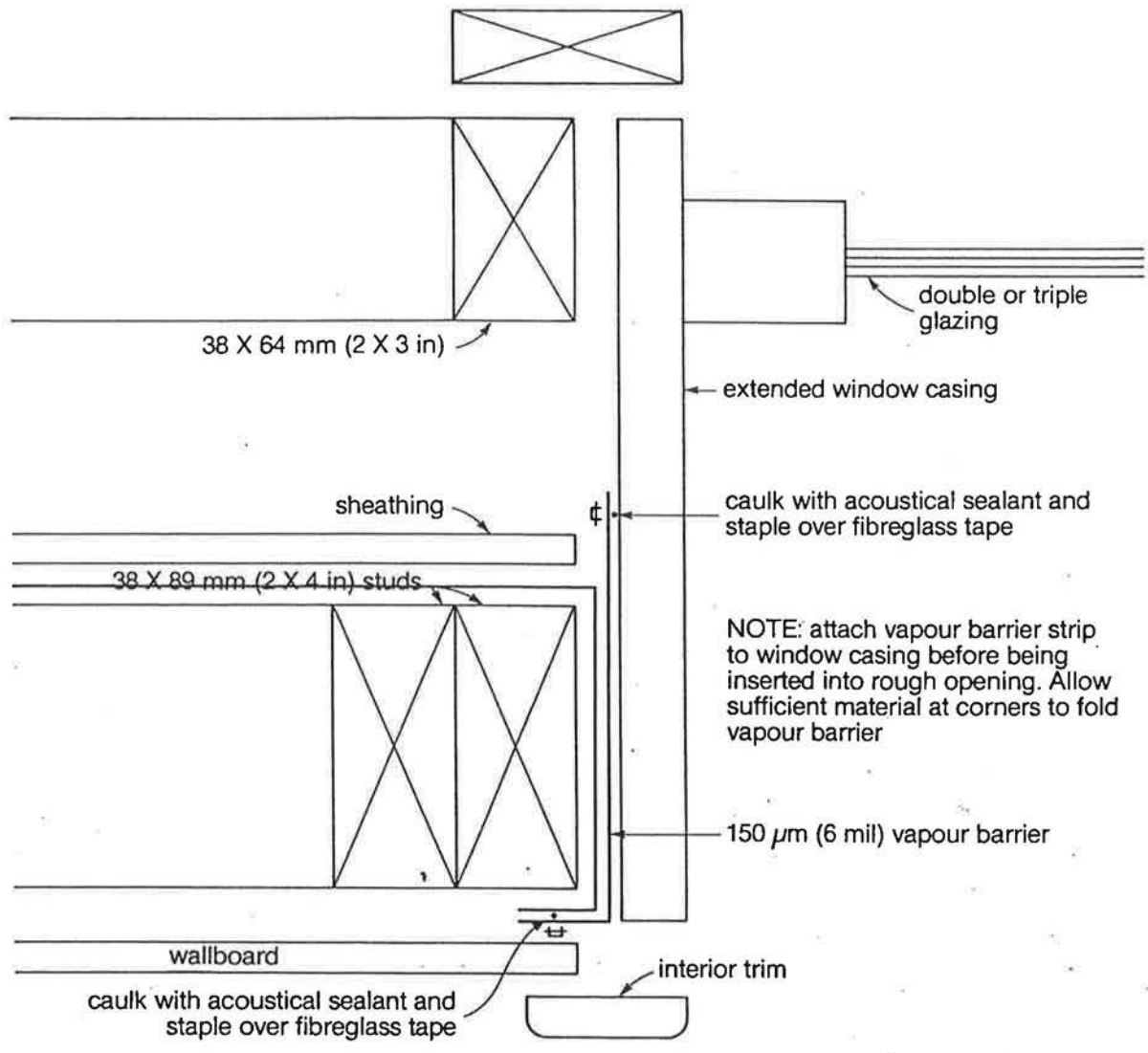

FIGURE 12. Window detail for double stud wall

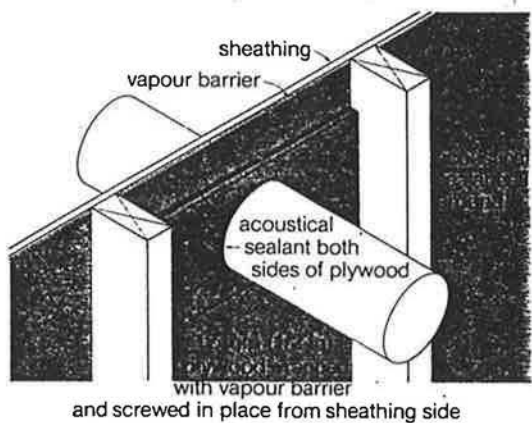

FIGURE 13. Technique for sealing pipes, vents, penetrating vapour barrier

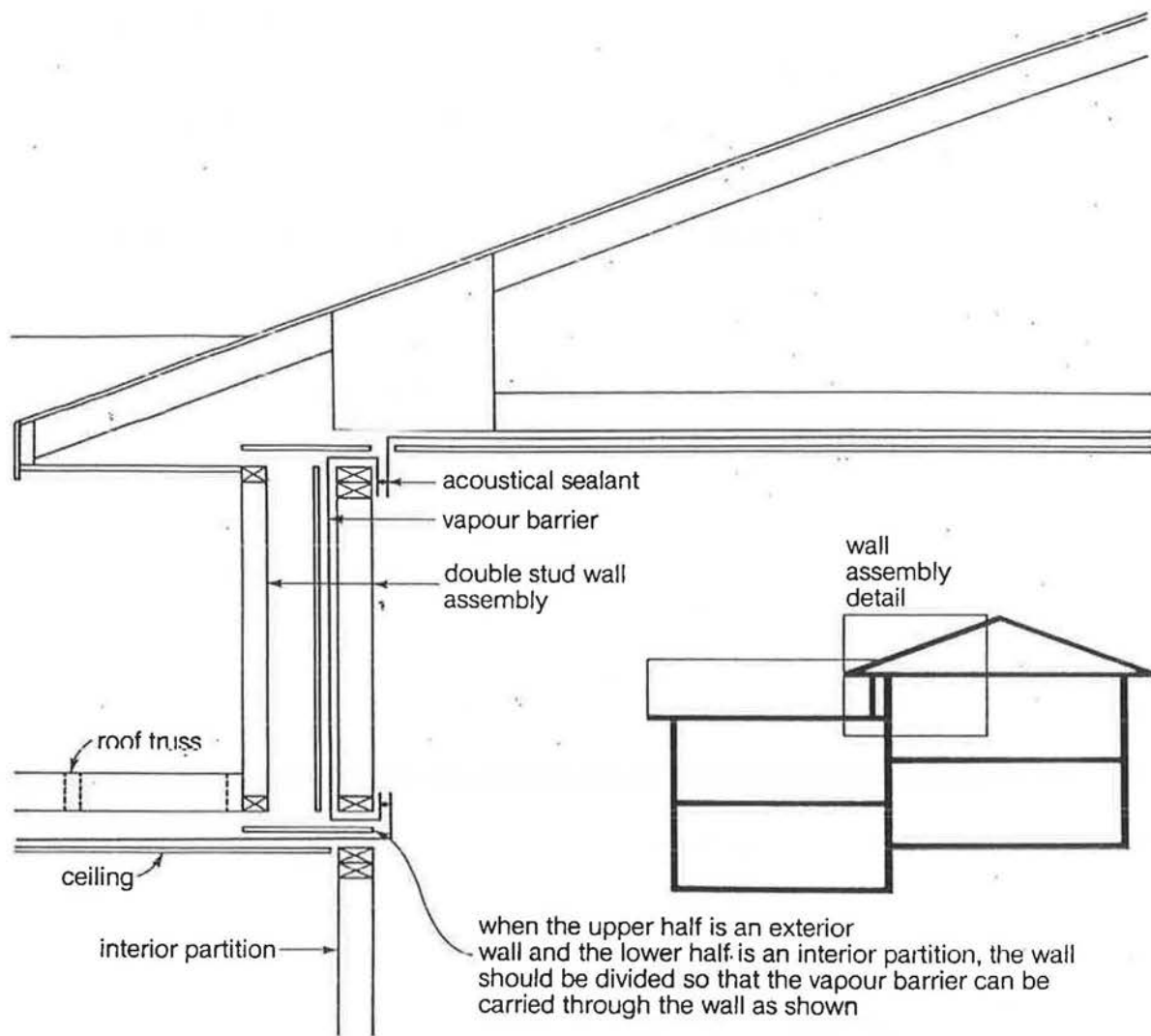

FIGURE 14. Split level house vapour barrier detail

For the ceiling, the techniques shown in Figures 5 and 7 will work. To prevent drywall screws from ripping the vapour barrier, chalk lines should be used to ensure that the screws do not go astray. Light fixtures should preferably not be located in ceiling with vapour barriers. Place them on interior walls.

2.1.2 Windows

Openable windows should be of a tight fit to prevent air leakage. Sliding windows, as a rule, tend to be poor performers because they must be loose in order to slide. Preferred window types are the casement, awning, or hopper units as shown in Figure 15.

2.1.3 Doors

Preferred doors are units that provide a good insulation level and have a good air seal. Hollow core doors are poor on both points. Commercial doors that have proven satisfactory are steel units with polyurethane cores. Special care should be taken with the weatherstripping. An outside storm door that has a screened openable window is often useful for extra summer ventilation of the house.

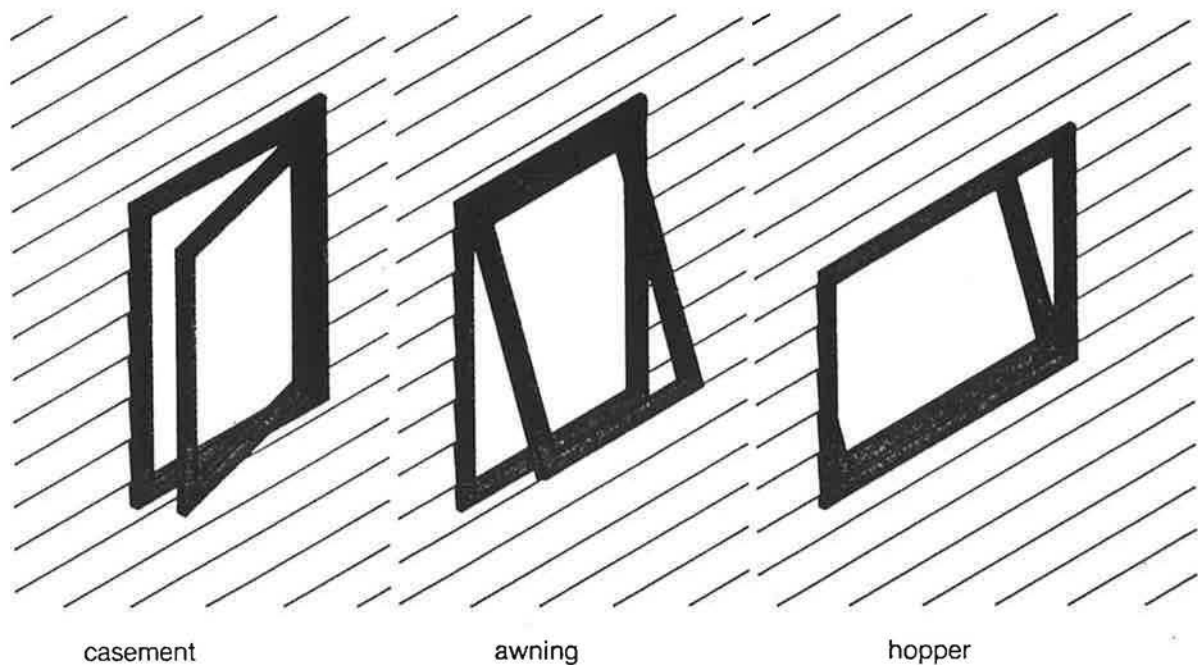

FIGURE 15. Preferred openable window types

2.1.4 Ventilation and Dehumidification

A well-sealed house **must** have some provisions for bringing fresh air into the house. For average-sized, well-sealed houses, a continuous ventilation rate of 30 to 40 L/sec. (60 to 80 cfm) should be adequate to control excess humidity. Note that in a well-sealed house, you do **not** have to use a humidifier. In fact, you have to remove moisture. If this is not done, large amounts of water vapour inside the house will condense on the windows during cold weather.

The sources of this water vapour are people, cooking, bathing, laundry, and plants. Each adult is responsible for about 0.1 L/hr. of water (0.25 lb./hr.) released into the house directly from the body. Over a 24-hour period, a family of four would release about 7 L (15 lbs.) of water into the air directly in the house. In addition, moisture from cooking, bathing, clothes drying, and plants could double or triple this amount of moisture. Those houses with larger numbers of people could experience even larger amounts of moisture inside.

In a typical conventional house, this moisture is removed by air leakage. (Outside air in winter almost always is drier than inside air, and thus outside air introduced to the house

reduces the moisture level.) New houses have greater moisture problems, as the lumber, gypsum board, and concrete tend to have high moisture content initially, which gradually reduces over time.

Allowances must be made for combustion air for fireplaces, furnaces or any other fuel burning appliances. Unvented appliances such as gas stoves produce moisture and carbon dioxide, both of which must be controlled in an air-tight house.

Several approaches to this moisture problem have proven useful:

- Use triple glazing on the windows. There should be a minimum of 12 mm (½ in.) air space between panes. Less moisture will condense on a triple-glazed window than on a double-glazed unit. Triple-glazing is about 20 to 40% more expensive than double, however.
- Place windows in inner-most wall in double wall construction, where they are sheltered from the wind, and inside air can circulate over the inner surface more easily.
- Use an insulating strip on the bottom part of the outside of windows. Placed as shown, the insulation will keep the inner window warm at the bottom, preventing water from dripping on to the window sill (see Figure 16).

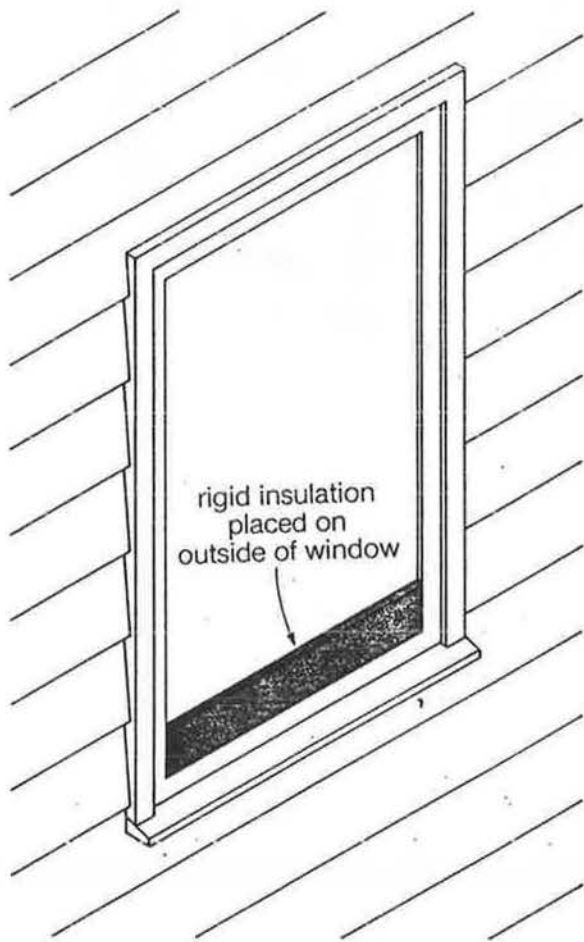

FIGURE 16. Technique for reducing condensation at the bottom of windows

- Use a dehumidifier. An electrically driven dehumidifier will help to lower the humidity in the house to some extent. It uses a large amount of electric power, however, and present models cannot lower the relative humidity much below 50%.
- Use an air-to-air heat exchanger. If the humidity level in the house is at a high level in winter, you likely need more outside air for odor and humidity control. The air-to-air heat exchanger will provide this fresh air at a low energy cost. An air-to-air heat exchanger is a device that uses the heat in the warm exhaust air from the house to heat the incoming fresh air. Its operation is fairly straightforward (see Figure 17). A properly designed unit will heat up the cold air entering the house to within a few degrees of the room air temperature. For do-it-yourselfers, and those wishing to learn more about the exchanger, a pamphlet on how to construct a unit is available (*An Air-to-Air Heat Exchanger for Residences*. Extension Division, University of Saskatchewan, Saskatoon, S7N 0W0, \$1.00). As of 1979, the complete units were being installed for about \$400 on a house, yielding savings of about \$50 per year. Those building an energy-efficient house should seriously investigate the use of such a device.

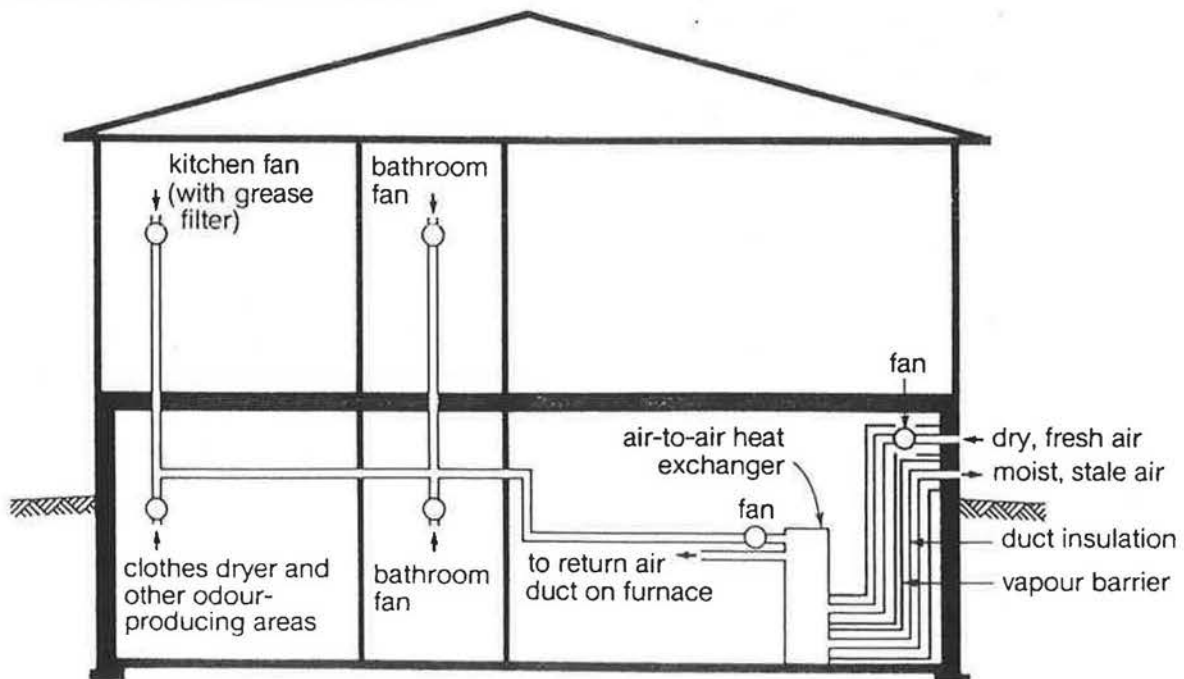

FIGURE 17. Air flow through an air-to-air heat exchanger

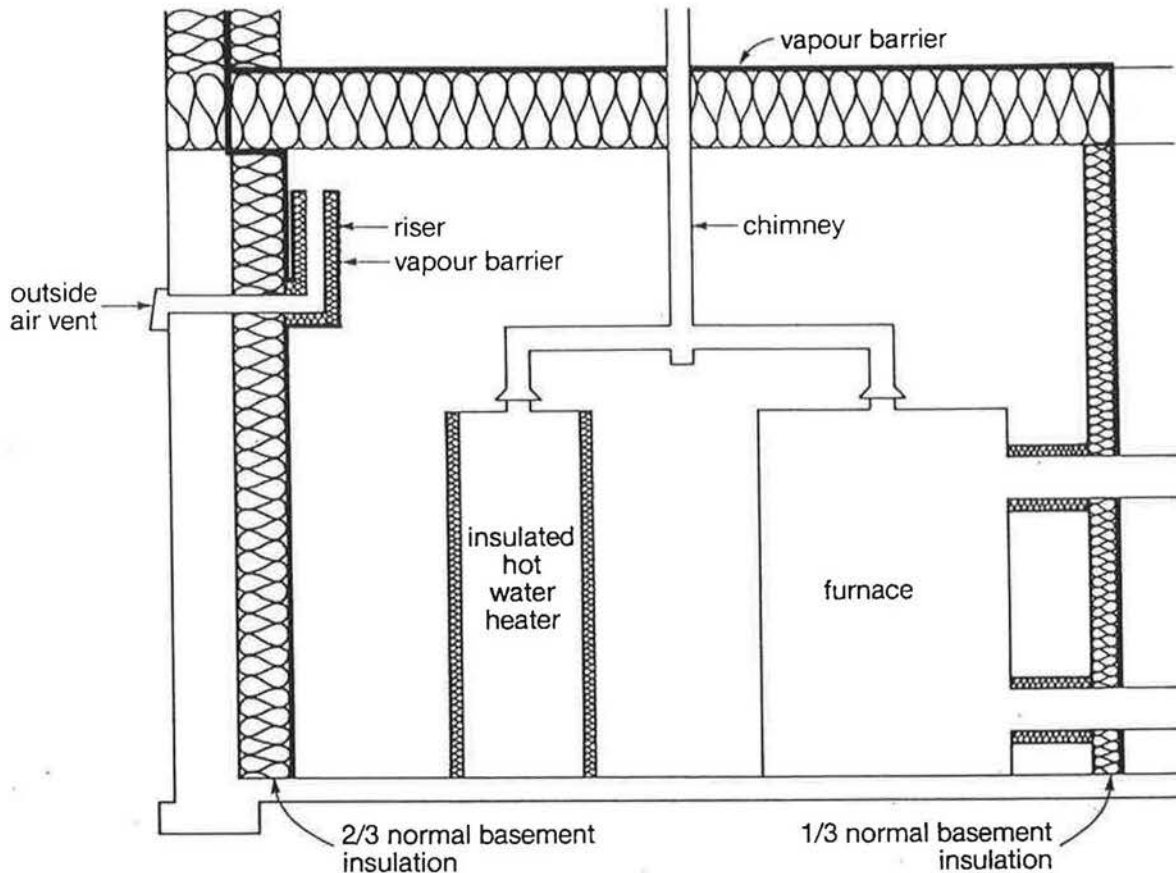

FIGURE 18. Use of a furnace room to isolate fuel burning equipment from the rest of the house

- Use an outside air vent connected to the return air duct on the forced air furnace. This method is not recommended but is mentioned here because it is the way most houses now receive fresh air. Avoid it by making use of an air-to-air heat exchanger.

2.1.5 Fuel Burning Apparatus

A chimney is a hole in the house and will allow a considerable amount of air to leak out. Imagine how much heat would leak out your front door if you had a hole in it the size of a chimney. If you use a chimney in the house, the best strategy is probably to build a furnace room against an outside wall, put your furnace and hot water heater in it and supply outside combustion air through a vent in the wall (see Figures 18 and 19). The furnace room should be tightly sealed from the rest of the house (using the vapour barrier techniques described earlier), and the furnace air ducts passing through the furnace room should be insulated, as should the water pipes. Electrical wires can be placed on the inside of the

vapour barrier. Care should be taken to see that the room does not freeze, as the water pipes would also. This can be done by placing two-thirds of the total wall insulation (resistance value) on the external wall and one-third on the interior wall.

The furnace chosen for the house should be on the **small** side. An average-sized energy-efficient house will likely have a design heat loss of no more than about 6 kW (20 000 BTU/hr.) at -35°C . Thus, the gas furnace should not be greater than about 50 000 BTU/hr. For best efficiency, one should purchase a furnace with electronic ignition and positive chimney damper.

If you plan to use a wood heating apparatus in the house, a similar provision should be made for outside air. In general, the air-tight wood stoves with baffles are much more efficient than the conventional open-hearth fireplace. A word of warning — an energy-efficient house needs very little heat — so buy a small woodburning stove.

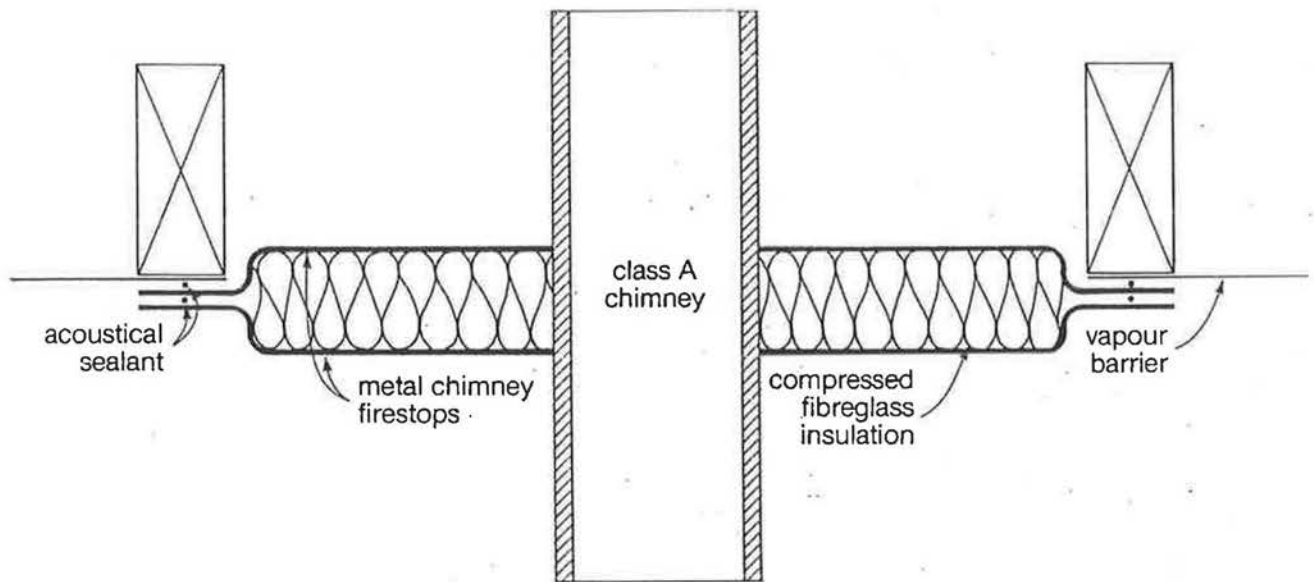

FIGURE 19. Chimney installation detail

2.1.6 Exhaust Vents

Vents for exhaust fans from kitchen and bathrooms usually are ducted to the nearest outside wall or to the roof. If the vent is located in the upper part of the house, air will tend to leak continuously out of the house through the vent, as the dampers are usually poor. As this moist air leaks out, moisture often condenses in the duct and runs back into the house, staining the ceiling or wall. A preferred technique for locating these vents is shown in Figure 20. Locate the exhaust fan on an interior wall and run the duct work into the basement and to the outside as shown. With this arrangement, any air leaks past the damper will result in dry outside air leaking inward, and no condensation will occur. (Under normal circumstances in winter, air tends to leak into the bottom parts of the house and to leak outward at the top parts.) This arrangement makes the installation of an air-to-air heat exchanger much simpler.

2.2 Insulation

2.2.1 Recommended Levels

The choice of the amount of insulation to use depends on a large number of factors — most of them known but some unknown, — such as the future price of energy. The insulation levels suggested here provide a range which we feel is appropriate for the southern Canadian Prairies.

TABLE 1
RECOMMENDED INSULATION LEVELS
ENERGY EFFICIENT HOUSES

	RSI (Metric)	R-Value (Imperial)
Ceiling	9-14	50-80
Walls above grade	5-9	30-50
Walls below grade	3.5-5	20-30
Floors over crawl space	5-7	30-40
Under basement floor of concrete	1-2	5-10
Window shutters	2-3	10-15

The most commonly used insulation materials for new houses are glass fiber and cellulose fiber. The cellulose fiber is used in ceilings or floors, but not ordinarily in walls, while the glass fiber is used throughout houses. A more detailed description of insulation types is provided in the free booklet **Keeping the Heat In**, available from the federal Department of Energy, Mines and Resources in Ottawa.

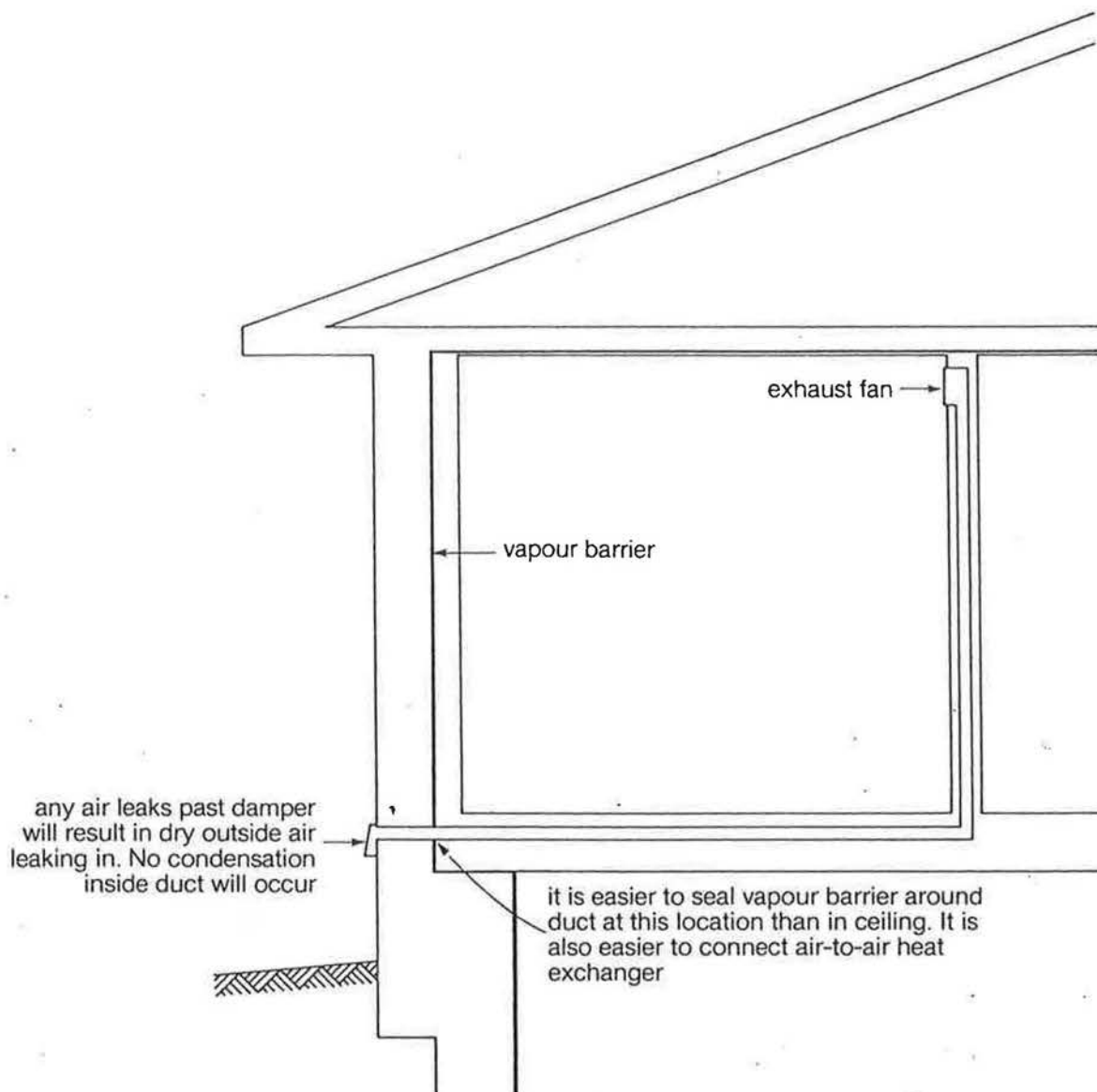

FIGURE 20. Preferred duct arrangement for exhaust fans

2.2.2 Construction Techniques

To illustrate how the insulation levels suggested in Table I could be incorporated in new construction, the following sectional views (Figure 21-25) of houses are shown. To illustrate placement of the vapour barrier, the wall sections are slightly expanded.

SINGLE STUD WALL

Single stud wall plus insulation foam, pressure treated wood basement (PWF), on concrete footings (Figure 21):

This single stud design incorporates a num-

ber of features which differ from standard construction. Note the continuous vapour barrier between basement and main floor. To minimize heat loss at the bottom plate of the wall, a 38 mm x 89 mm (2 in. x 4 in.) plate is used, rather than a 38 mm x 140 mm (2 in. x 6 in.) plate. A major disadvantage with the single stud wall is that it requires you to place the vapour barrier on the inner surface. As mentioned earlier, the vapour 'pans' for electrical wiring must be used with this technique. In addition, much greater care must be used when installing the drywall. In certain areas of Canada, the pressure treated wood basement

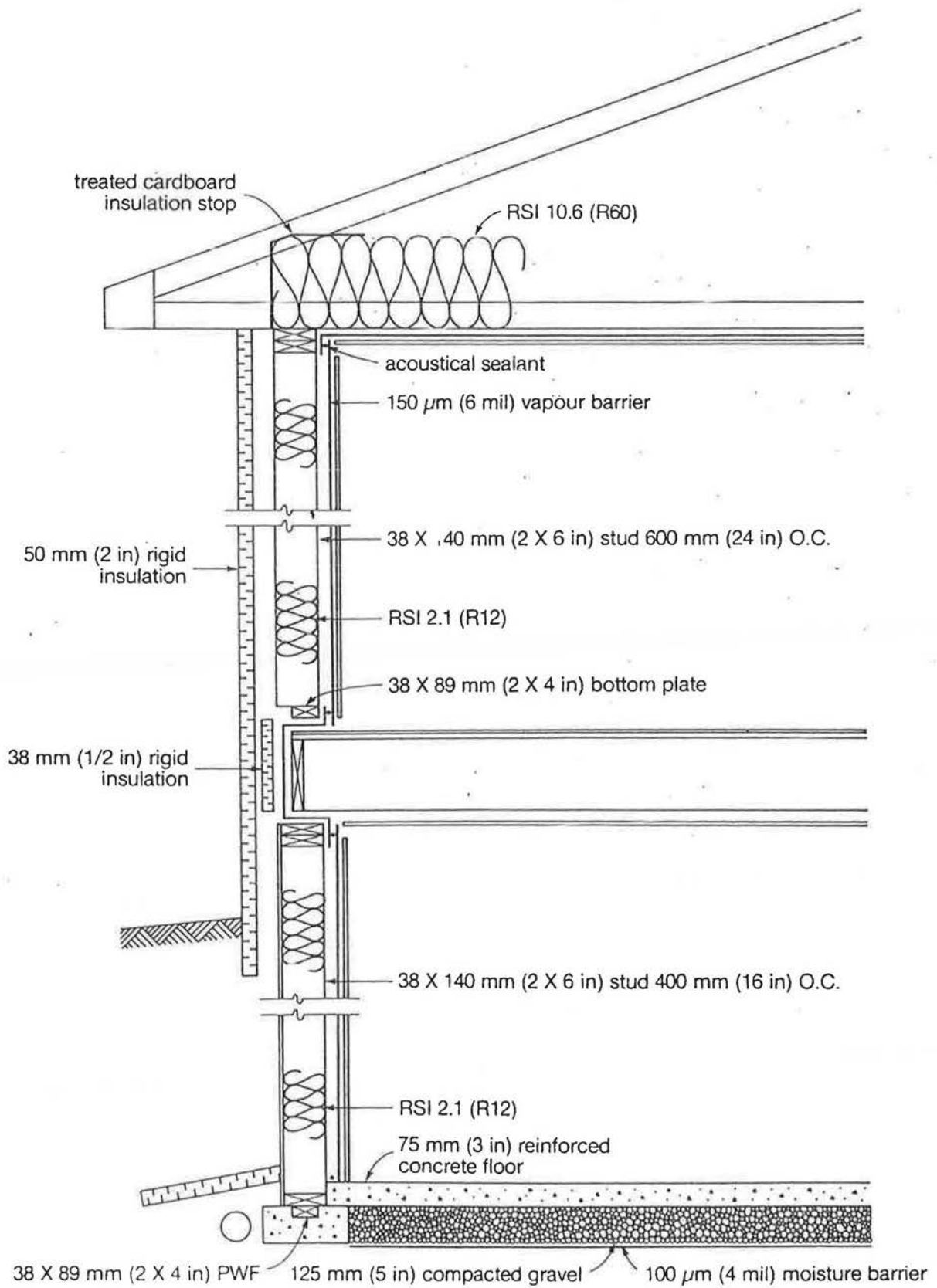

FIGURE 21. Wall section

is not recommended — be certain that the foundation design you choose conforms to acceptable local practice.

Another variation of this single stud design is the use of 38 mm x 38 mm (2 in. x 2 in.) horizontal strapping on the inside, and placing the vapour barrier as shown in Figure 22. This allows the electrical wires to run inside the vapour barrier. To insulate the 38 mm (2 in.) gap, thicker batts may be "peeled" to fit. Preplanning is required around windows, doors, and at corners for the carpentry.

DOUBLE STUD WALL

Double stud wall, pressure treated basement (PWF) on gravel pad, crawl space (Figure 23):

This design used the double stud wall assembly shown in Figure 10. Note that a floor truss design is used, rather than solid joists. The floor truss allows one to easily pass electrical wires, ductwork, and plumbing. It simplifies the finishing of the basement ceiling. In addition, trusses are less prone to warping than solid joists. Note that a crawl space is incorporated under the basement floor. In a

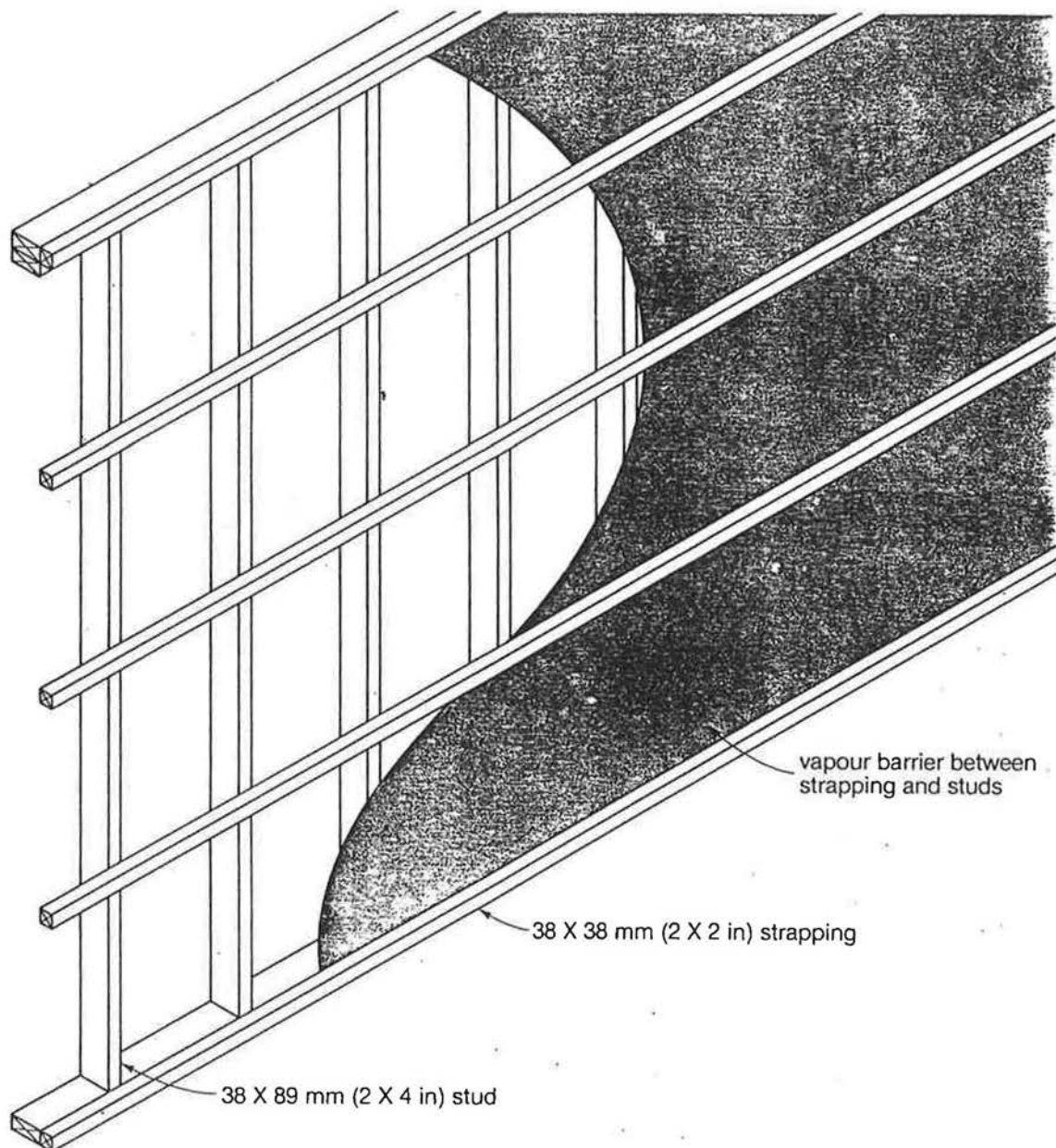

FIGURE 22. Single stud wall with strapping on the inside

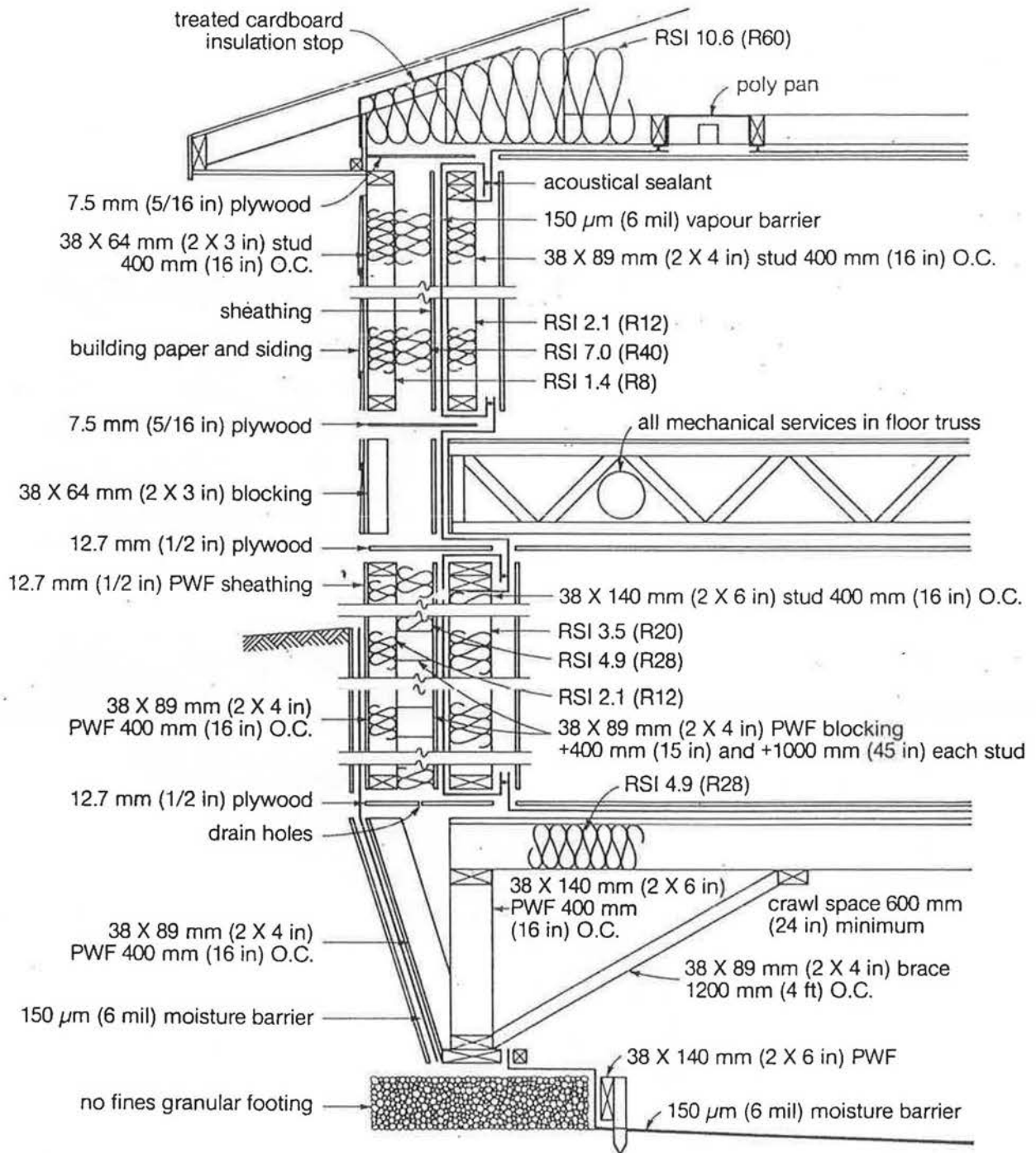

FIGURE 23. Wall section - pressure treated wood foundation

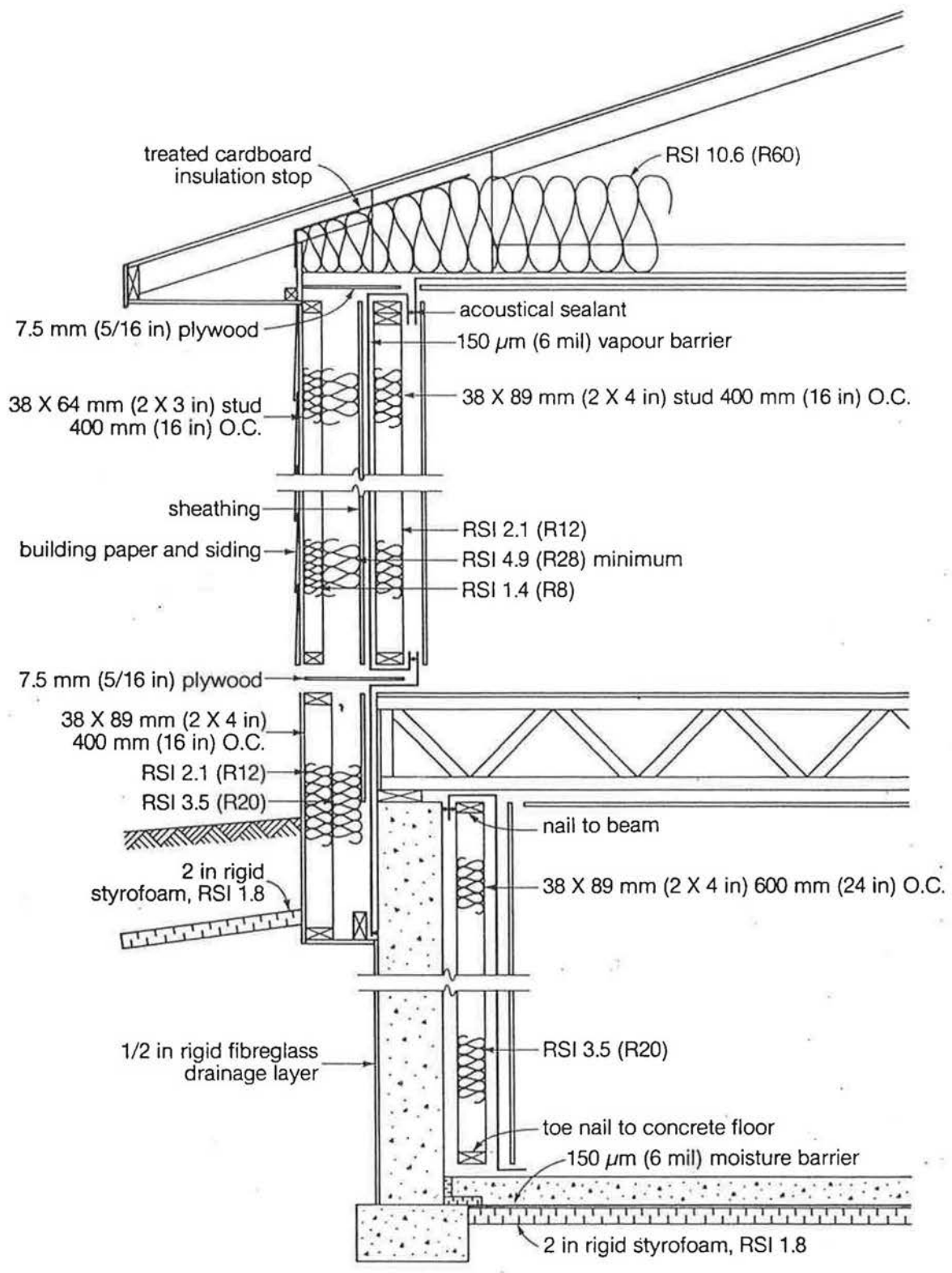

FIGURE 24. Wall section - concrete wall and footing foundation

flood situation, up to 2 ft. of water can be accumulated without serious problems.

CONCRETE WALL AND FOUNDATION

Concrete wall and footing foundation (Figure 24):

This design incorporates a double stud wall and a widely used foundation technique. Some of the disadvantages are as follows: potential moisture problem in insulation in lower level and subsequent dry rot of wall system, extra cost for double insulation of foundation, vapour barrier in basement on the inside of the wall, and flooding a more severe problem.

GRADE BEAM AND FOUNDATION

Grade beam and pile foundation (Figure 25):

This design is more flood proof, requires little excavation, and little treated wood. Some of the disadvantages are that piles and grade beam (not a standard residential system) are required, frost protection for sewer and water leaving the house may be required, and most people still expect a basement in this part of the world. This is the type of system that was used on the Saskatchewan Conservation House in Regina.

2.3 Passive Solar Gain

2.3.1 South-facing Windows

In an ordinary house, sun shining through south-facing windows during the winter months does not reduce the fuel bill by more than about 1%. In an energy-efficient house, however, the solar gain from these windows can provide a very substantial part (30% or more) of the heating load.

With shutters on a south-facing window, you have a low-cost solar heating system. In the summer time, an overhanging eave or an awning will limit the undesirable overheating from too much sunshine.

With the windows facing south, one can expect a temperature swing in the house particularly during sunny days in spring and fall. To prevent the temperature from rising too much in the house due to solar heat from the windows, the following rough rules of thumb can be used to determine the proper amount of south-facing glazing:

- In an ordinary wood frame construction house with gypsum wallboard, limit the south-facing window area to about 6 % of the floor area. Thus, for a 100 m² (1075 sq. ft.) main floor plus a 100 m² basement, use about 12 m² (130 sq. ft.) of south-facing windows. If more window is used, overheating will likely occur in spring and fall unless extra mass is used inside the house to absorb the extra solar heat that occurs on sunny days. Note: Some people using larger window areas provide for extra ventilation or do not mind a larger temperature swing.)
- If more than 6% south-facing window area is used, some provision for extra mass inside the house should be made. Another rough rule of thumb is that 5 m² (54 sq. ft.) of 100 mm (4 in.) thick concrete should be used for each square metre of south-facing window beyond the 6% figure. This concrete can be in the form of 100 mm (4 in.) thick solid concrete blocks, used as interior walls. Unless the sun shines directly on the wall and the wall is dark coloured, the concrete wall need not be any thicker than 100 mm (4 in.). Insulating the outside of a concrete basement wall helps to add extra heat-absorbing capacity. One very inexpensive technique for getting additional mass into the house is to cut the scrap gypsum board into strips and place it within the interior walls of the house.
- The overhang should be designed to allow full sun into the windows until February 1. At Saskatoon (Latitude 52° N) and Edmonton (Latitude 53° N), this sun angle is 20° above the horizon at solar noon requiring a roof overhang of about 1 m (40 in.) for a window with its top part at the standard height of 2 m (6ft. 8 in.) above the floor (Figure 26). Ideally, one would want an adjustable overhang, which would be zero in the heating season, and large enough to prevent direct sunshine from entering the window in the cooling season. An awning or movable overhang will do this. If you have insulating shutters on the windows (this is highly recommended) you can also use them as a form of shade to prevent overheating of the house during warm days in the spring and fall.

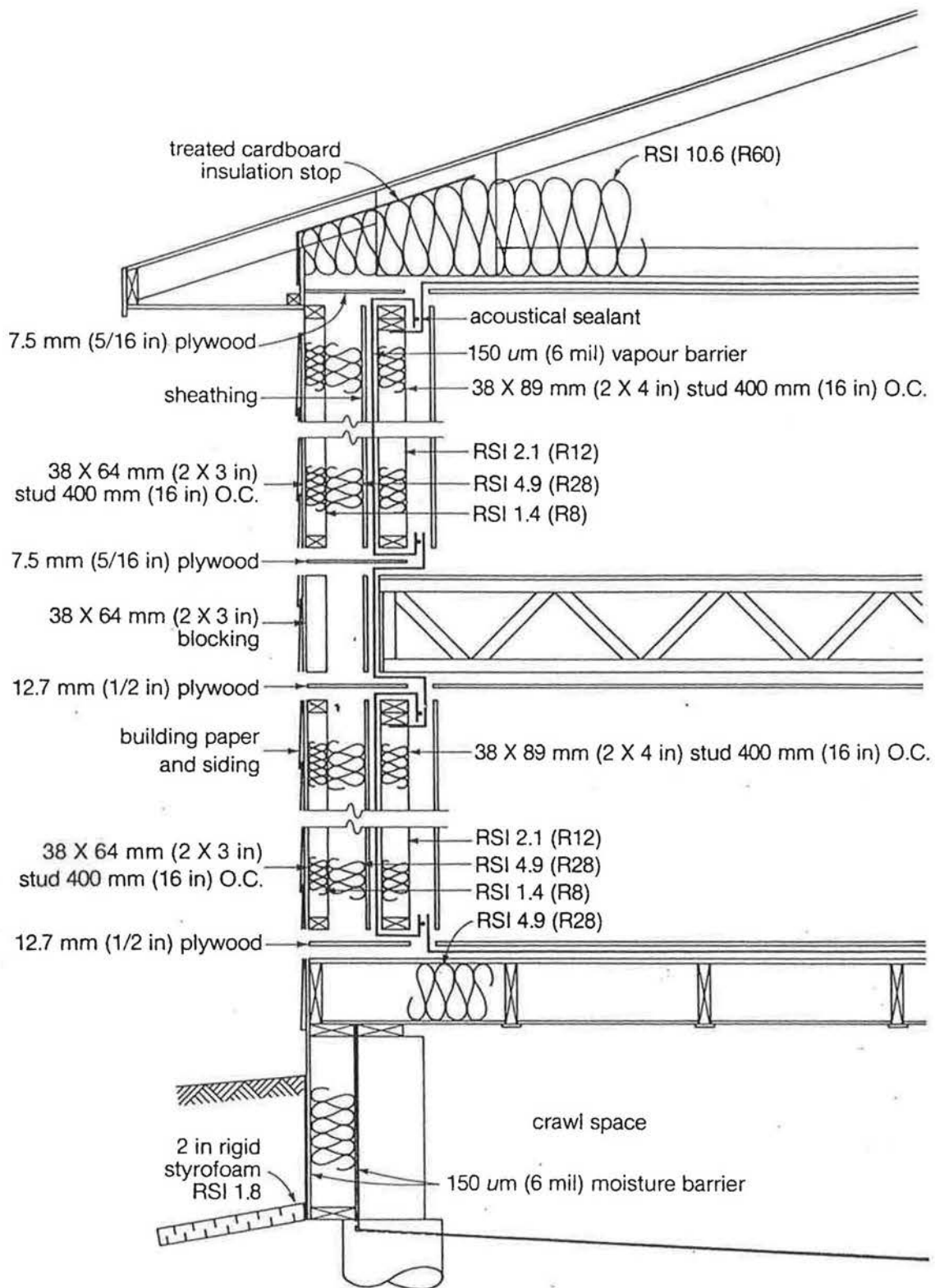
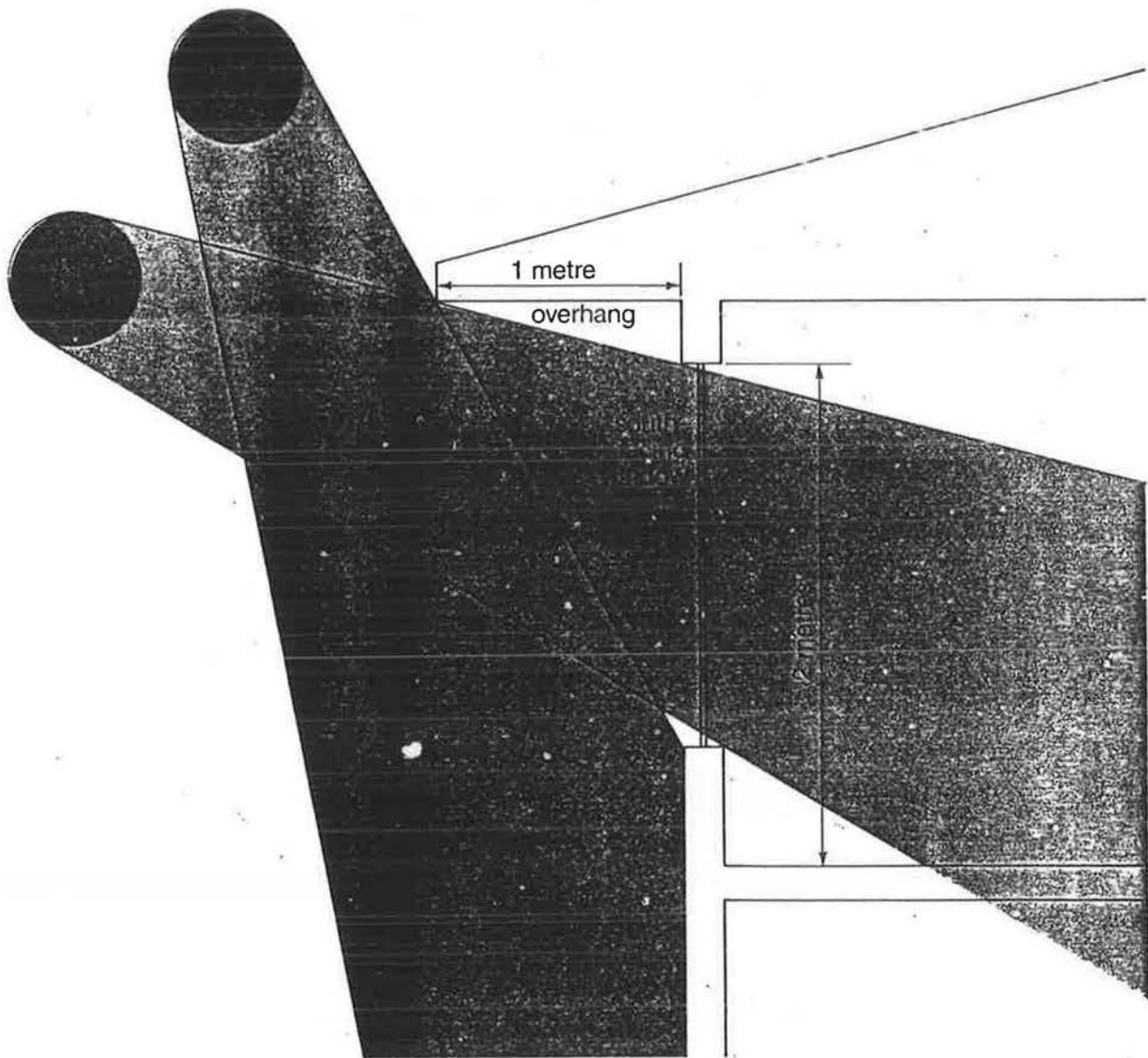

FIGURE 25. Wall section - grade beam and piling foundation



angle of sun above horizon at 52° N. latitude:

Jan 21	Feb 21	Mar 21	Apr 21	May 21	Jun 21	Jul 21	Aug 21	Sept 21	Oct 21	Nov 21	Dec 21
18°	27°	38°	50°	58°	61°	58°	50°	38°	27°	18°	14°

FIGURE 26. Use of an overhang to limit summer sunshine into house

2.3.2 Heat Distribution

- For some houses, use of a vertical concrete heat storage wall (Trombe Wall) may be made to redistribute heat from the rooms receiving the sunlight to the other rooms. A conventional forced air system will do a good job of redistributing heat throughout

a passive house. Use of a 2-speed fan can reduce the power requirement. In houses with baseboard hot water or electric heating, a separate fan and duct would be required to distribute heat to the basement and to rooms located away from the sun-heated rooms.

2.4 Use of Windows for Lighting

Electricity is a highly refined form of energy, and in an energy-efficient house, its use should be minimized. During the day, natural lighting can be provided by windows throughout the house. To prevent heat loss at night, insulating shutters should be used. In general, you should concentrate the windows on the south side of the building, and use the north side of the building for bedrooms, bathrooms, utility rooms, and storage.

2.5 Insulating Window Systems

Double-glazed or even triple-glazed windows do not provide much of a barrier to heat loss. However, a south-facing window can act as a solar heat collector during the day. To reduce heat loss at night, an insulating blind or shutter should be used. A large number of shutter schemes are being built these days, and a book by William Shurcliff, **Thermal Shutters and Shades**, has a wealth of ideas. Here are some of these ideas that we think are practical:

SMALL WINDOWS

For such windows, a hinged or sliding type of interior shutter, weatherstripped around the edge to limit moisture buildup on the window pane can be successful. A disadvantage with this scheme is that the window gets very cold during the night, and will fog up with moisture temporarily in the morning when the shutter is opened. It is noted that on south-facing windows defogging will be more rapid. Ideally, one would like to have the shutter on the outside of the window. As yet, however, there are no simple cheap exterior shutters of high insulating value for small windows that can be operated from inside the house. A design for an interior hinged shutter is shown in Figure 27.

BIG WINDOWS

With big windows there exists a real problem with "parking" a large shutter. It can be done by sliding or hinged or bifold panels. The book **Low-Cost Energy-Efficient Shelter** by Eugene Eccli has a useful chapter on shutter designs. In all shutter designs, a good seal is required around the edge to limit air movement.

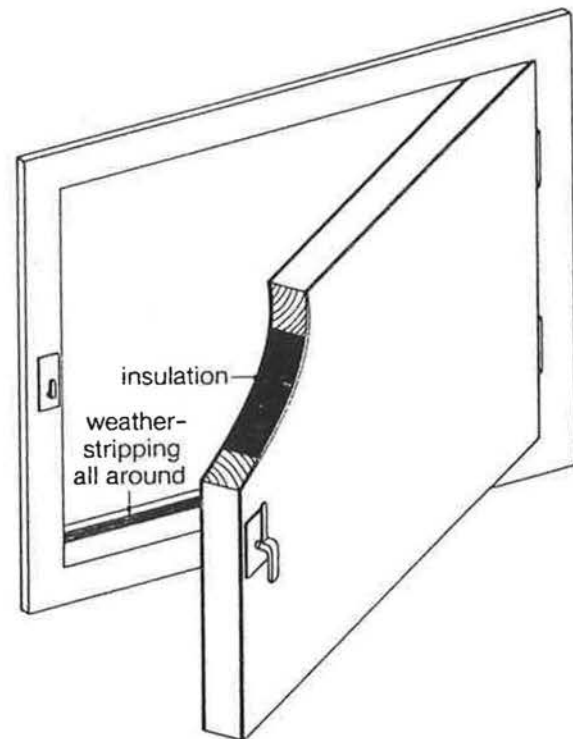

FIGURE 27. Interior shutter for window

Refitting an Older House

A number of older houses in Saskatoon have been reinsulated to near Conservation House standards. The technique used was to build

outward from the existing house. The steps used are shown in Figures 28 and 29.

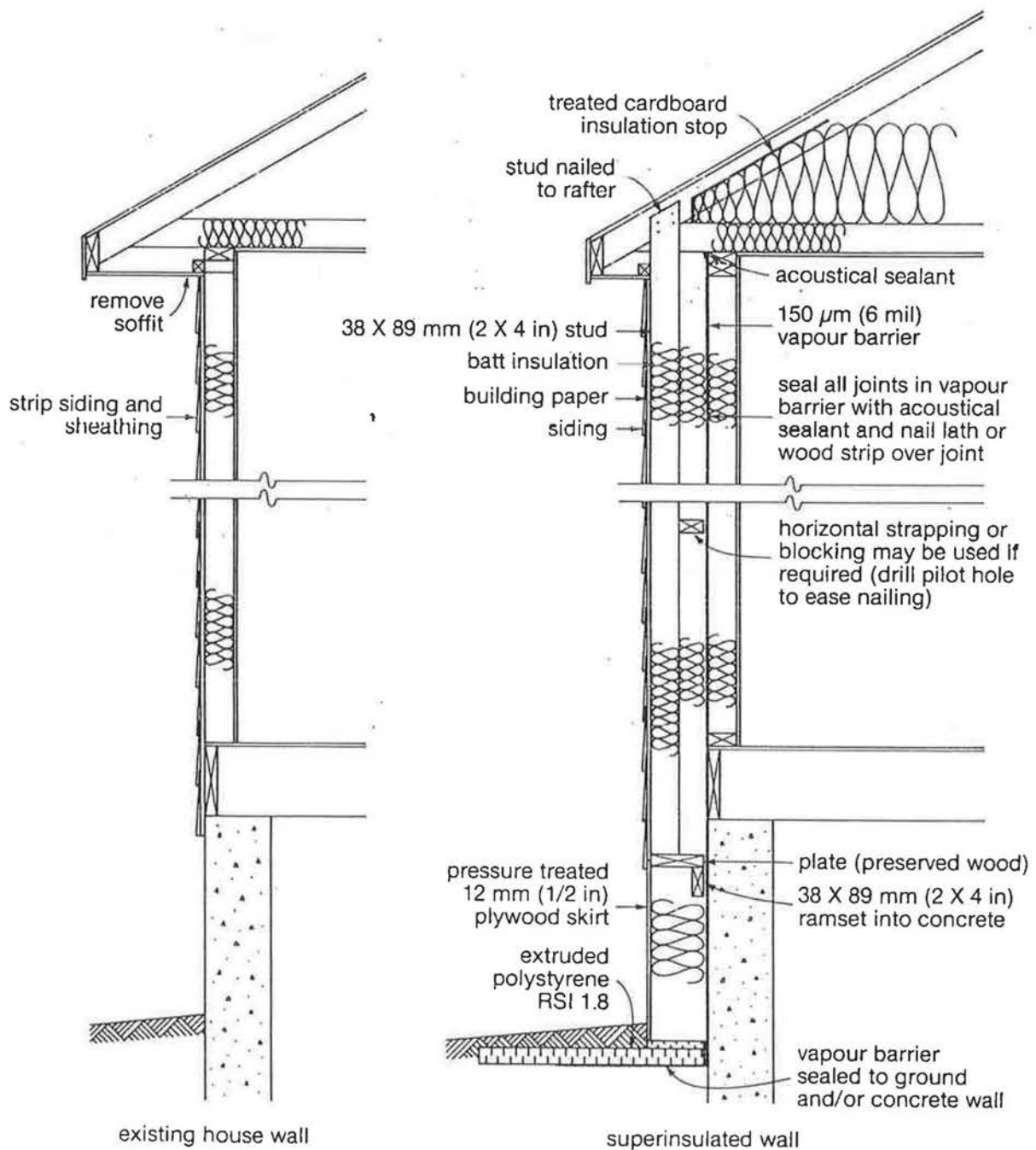

FIGURE 28. Technique for super-insulating the exterior walls of an existing house

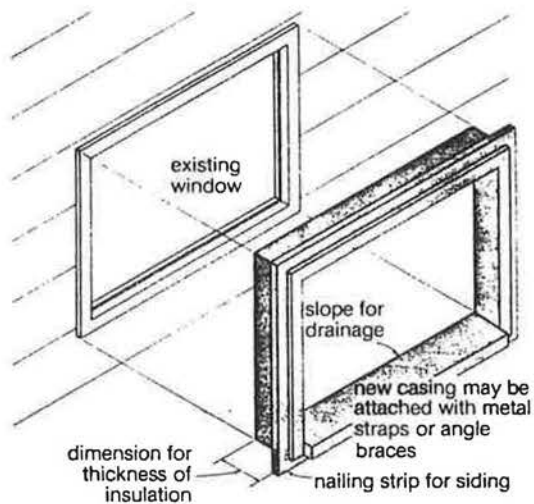

FIGURE 29. Detail of built-out window casing

- Strip existing siding (if desired for reuse)
- Add polyethylene vapour barrier to outside of sheathing
- Seal all joints in vapour barrier and seal to window and door casings
- Add strapping
- Build out window and door casings
- Insulate
- Install building paper
- Install siding

Reinsulation techniques for the remaining part of the house are fairly standard. However, before you add insulation to the attic, we recommend that you go into the attic and seal it properly. A recent booklet put out by Saskatchewan Science Council, **Seal Your House Before Reinsulating**, has an excellent description of the procedure (see Information Sources).

4

Water Heating

An energy-efficient house will often have a water heating bill that is greater than the space heating bill. An average family uses about 14.4 GJ (4 000 kWh) for hot water heating annually. As shown in Figure 1, the space heating load for a conservation house (5-20 GJ) would be about the same size. Here are some standard techniques that can be used to reduce energy consumption for hot water.

- Use showers instead of baths. Showers should be short!
- Fix leaky faucets. A dripping faucet can cost up to \$15 extra per year.
- Wash full laundry loads; rinse in cold water.
- Add insulation to the hot water tank and to the water lines leading in and out of the tank. Keep the distance between the hot water tank and the usage points in the house short. Insulate the hot water lines in the house.
- Set water heater temperature at 50° C (120° F).

4.1 Two-tank System

In many parts of Saskatchewan and Alberta water enters houses at about 5° C. The following technique will allow you to preheat this water before it goes into your regular hot water heater (see Figure 30). An additional uninsulated water holding tank allows heat to be transferred from the room air to the water. Assuming that the room air is at about 20° C, the water will be preheated as it sits in this tank. Although one is taking heat from the house to accomplish this water preheating, in a low-energy house there is generally an excess of heat available for about eight months of the year.

If insulating a natural gas or oil-fired water heater, do not obstruct air flow into burner or chimney draft air. Leave the access panels and junction boxes on an electrical water heater uninsulated. Electric wire insulation and the controls have been known to melt when heavily insulated.

4.2 Low Cost Solar Panel Designs

A number of relatively inexpensive solar domestic hot water heater designs are possible. For commercially installed units, the price was about \$3000 as of the spring of 1979 for flat plate solar panel systems that would provide about 50 to 75% of an average family's hot water requirement. For the avid do-it-yourselfer, systems can be built for about \$750 to \$1000 for the materials. A number of do-it-yourself plans are now available commercially.

As an average family spends about \$50 to \$100 per year for hot water, the do-it-yourself designs are fairly cost effective — the more expensive commercially installed units less so. Typically, one would want about 6 to 8 m² (65-85 sq. ft.) of panels facing south at a tilt angle somewhere between 60 to 90° to the horizontal. Collectors should be at least double glazed and preferably have a selective surface on the absorber plate to work satisfactorily in our Prairie climate. A number of precautions to follow in buying a commercial system are the following:

- Consult several sources before making a selection.
- Obtain a written quote on the complete job, including materials, labour, permits, fees, and service contract charges.
- Determine the contractor's local reputation.
- Require a written warranty. It should be at least one year on parts and labour, three years on collectors.
- Obtain in writing an estimate of the system's performance.
- Select a system with adequate protection against freezing.

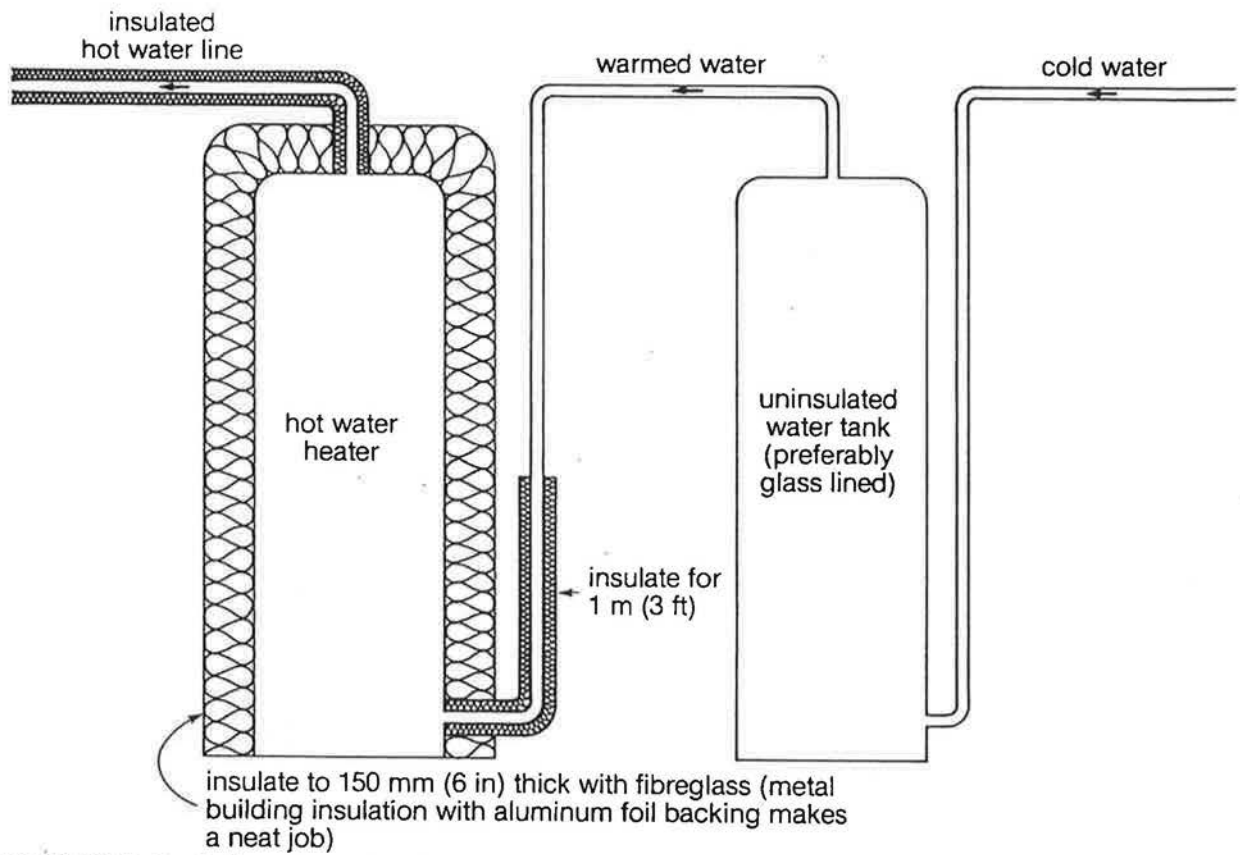

FIGURE 30. Technique for preheating hot water and insulating hot water tank

Energy Conservation in Electricity Usage

Several excellent publications, such as **100 Ways to Save Energy**, give detailed information on reducing electricity consumption. Here are some of the key points to remember.

5.1 Choice of Appliances

The big electricity consumers in most people's houses are the following:

	Annual Electricity Consumption	
	Gj	kWh/year
Electric hot water heater	14.4	4000
Freezer (manual defrost)	2.16	600
(frost free)	4.32	1200
Stove	4.32	1200
Refrigerator (manual defrost)	3.06	850
(frost free)	4.32	1200
Clothes dryer	3.24	900
Furnace fan	2.88	800
Dishwasher (excluding hot water)	1.08	300
Clothes washer (excluding hot water)	0.324	90

Source: **100 Ways to Save Energy and Money in the Home**

An average family uses about 21.6 Gj (6000 kWh) for electricity (assuming that electricity is **not** used for hot water heating). The refrigerator (4.32 Gj 1200 kWh), stove (4.32 Gj, 1200 kWh), clothes dryer (3.24 Gj, 900 kWh), and furnace fan (2.88 Gj, 800 kWh) comprise about two-thirds of the total electricity usage in an average home. Thus, one can save the most electricity by proper selection and use of these appliances.

REFRIGERATORS

The best models to purchase are the manual defrost types, **not** the frost-free units. If you have an old manual defrost unit and some trouble develops with it, have it repaired rather than replaced. The frost-free units use almost 50% more electricity than the manual defrost types.

STOVES

The best models to purchase are the self-cleaning oven types — they have more insulation and lose less heat from the oven than do the ordinary stoves. Just don't use the self-cleaning feature very often!

FURNACE FAN

With a smaller heat loss from the house, you will be able to install a smaller furnace, which will have a smaller fan. In addition, you may wish to consider using a two-speed fan on the air circulation system, which again will cut your electricity consumption.

LIGHTING

Use fluorescent lamps rather than incandescent bulbs. These lamps use about one quarter as much electricity to provide the same illumination. Use of small lamps for reading, etc. is preferred to illuminating the entire room with overhead lighting.

DISHWASHER

Do you really need one?

CLOTHES DRYER

In the summer a clothes line works well; in winter you can hang a lot of clothes on \$5.00 worth of rope. If you do use an electric unit, you can vent it directly into the house in the winter period, especially if you have an air-to-air heat exchanger. Don't try it, however, with a gas dryer, as this can be very dangerous.

CLOTHES WASHER

Use the lower water temperature setting when appropriate. Consider the purchase of a washer with a suds-saver option.

Information Sources

Much has been published recently on energy conservation. Here is a short list of some publications we think you will find useful in building an energy-efficient house.

6.1 House Construction - General

CANADIAN WOOD FRAME HOUSE CONSTRUCTION, Canada Mortgage and Housing Corporation (\$1.00). Available at nearest - CMHC office.

BUILDERS' GUIDE TO ENERGY EFFICIENCY IN NEW HOUSING, available from Housing and Urban Development Association of Canada, Communications Department, 15 Toronto Street, 10th Floor, Toronto, Ontario, M5C 2E3 (\$6.00).

6.2 House Plans for Energy-Conserving Houses

With some adaptation, such as orienting main living areas to the south with kitchen and storage on the northside, standard house plans can be used. Most larger magazine stores have booklets of house plans that can serve as a starting point. Often, the home plan services will adapt the plans to your needs.

6.3 Shutter Idea Books

THERMAL SHUTTERS AND SHADES, William Shurcliff, Brick House Publishing Co., Church Hill Harrisville, N.H. 03450, U.S.A. (\$12.00 U.S.).

LOW COST ENERGY-EFFICIENT SHELTER, Eugene Eccli, Rodale Press, Emmaus, Pennsylvania (1976).

6.4 General Energy Conservation

SEAL YOUR HOUSE BEFORE REINSULATING, Office of Energy Conservation, Department of Mineral Resources, Government of Saskatchewan, 1914 Hamilton Street, Regina, Saskatchewan, S4P 3P5.

100 WAYS TO SAVE ENERGY AND MONEY IN THE HOME

KEEPING THE HEAT IN

THE BILLPAYER'S GUIDE TO FURNACE SERVICING

These booklets are available free from the federal government, Department of Energy, Mines and Resources, Conservation and Renewable Energy Branch, 580 Booth Street, 6th Floor, Ottawa, Ontario, K1A 0E4.

ENERGY MATTERS

SOLAR ENERGY MATTERS

PROSPECTS FOR SOLAR AND WIND ENERGY UTILIZATION IN ALBERTA

These booklets are available free from Energy Conservation Branch, Alberta Energy and Natural Resources, 7th Floor, South Petroleum Plaza, 9915 - 108 Street, Edmonton, Alberta T5K 2C9.

6.5 Solar Heating Information

SOLAR SYSTEMS IN B.C., available from B.C. Hydro, Burrard Street, Vancouver, B.C. (\$2.00)

BUILD YOUR OWN SOLAR WATER HEATER, Garden Way Associates, Inc. Charlotte, VT 05445

SOLAR HEATING CATALOGUE 2, available from Energy, Mines and Resources, Ottawa.

THE SOLAR HOME BOOK, B. Anderson, Brick House Publishing Co., Church Hill, Harrisville, New Hampshire 03450, U.S.A. (\$8.50 U.S.)

NOTE: Some of the technologies shown and described in these books are not appropriate for the severe climate conditions in Canada and the Prairie Provinces particularly.

