

TRANSIENT THERMAL AND AERODYNAMIC MODELING OF PITCHED ROOF: EVALUATION OF THE POTENTIAL OF ENERGY RECOVERY IN THE AIR LAYER FOR HEATING PURPOSES

Maatouk, Chantal^{1,3}; Zoughaib, Assaad¹; Lemerrier, Hervé²; Weiland, Eric²

¹Mines-ParisTech, department of Energy and Processes, Palaiseau, France

²Terreal R&D, Castelnaudary, France

³Faculty of Engineering – ESIB, Saint-Joseph University, Campus des Sciences et Technologies, Mar Roukos, Mkalles, Lebanon

ABSTRACT

A pitched roof, subject to external climatic conditions, heats up by solar radiation throughout the year, even during the winter season. The air layer under the tiles is therefore heated by convection (natural or forced) with hot tiles.

In this study, the aerodynamic and thermal behaviour of a pitched roof is evaluated by means of coupled simulations between thermal simulation and Computational Fluid Dynamics (CFD). The aim of this work is to predict the temperature variation in the air layer under the tiles as a function of the quantity of air infiltrated through the tiles and the climatic conditions.

The work is divided into two parts:

- The first part consists on modelling the physical phenomena taking place in a pitched roof subject to solar radiation and to the forces of wind, all year around;
- In the second part, the developed model was validated experimentally using an experimental device.

Laboratory experiments and simulations showed that the wind speed and direction as well as the solar radiation has an important impact on the thermo-aerodynamic behavior of the roof, and it revealed that the air layer can be heated from 5 to 20 K, depending on the season. Finally, the potential of valorization of the available energy in the air layer is studied. Results show that the valorization of this energy can reduce the annual energy consumption for domestic hot water production of a single family house for about 20%.

INTRODUCTION

Solar energy intercepted by the Earth every minute is greater than the amount of the world energy needs in fossil fuels each year. Solar energy, radiant light and heat from the sun, has been harnessed by humans since ancient times using a range of ever-evolving technologies. Solar energy technologies include solar heating, solar photovoltaic, solar thermal electricity and solar architecture (International energy agency, 2011).

The recovery and the use of solar energy is very attractive and interesting, but at what price?

Nowadays, the payback time for solar energy systems varies from region to another and depends a lot on the public incentives. Sidiras and Koukios (2005) have evaluated the payback time of solar hot water systems and found that it varies between 7 and 11 years. Whereas, according to Jinqing et al. (2013), the payback time for photovoltaic solar panel depends principally on the efficiency of the panels and can vary from 3 to 12 years. This payback time takes into account the tax credit. In the absence of the latter, these systems will no longer be profitable; especially when the average lifetime of a solar thermal is about 15 years and that of a photovoltaic solar panel is approximately 20 years.

In 2011, the International Energy Agency said that "the development of affordable, inexhaustible and clean solar energy technologies will have huge longer-term benefits. It will increase countries' energy security, enhance sustainability, reduce pollution, lower the costs of mitigating climate change, and keep fossil fuel prices lower than otherwise."

Active solar heating systems are too costly and complex, and often aesthetically unacceptable. Alternative collector designs have been proposed by different investigators in order to improve the cost effectiveness and reduce the payback time of these systems. Belusko et al. (2004) have studied the economical and energy efficiency of a corrugate steel plate with and without glazing to replace classical solar panel, these systems appears to be cost effective but have a long payback time. Soltech Energy (2011) has proposed new glazed tiles to be used as solar collector on pitched roof. This system improves the heating of the air layer under the tiles in order to use it as an energy source for a heat pump. These collectors are efficient and aesthetic but they necessitate the change of the roof tiles and structure. Satag Viessman (2009) have developed a new flat-plate and tube collectors in steel and glazing, imitating the tiles shape, as a replacement of solar panels. These collectors are efficient, and preserve the aesthetics of the building; however the use of these systems requires lots of modifications in the roof and the building structure and induces an extra cost.

A pitched roof, subject to external climatic conditions, heats up by solar radiation throughout the year, even during the winter season. The air layer under the tiles is heated up by convection with hot tiles. In this paper, a new method for recovering solar heat from hot air layer under the roof tiles is presented. The proposed collector has the advantage of being able to integrate into the air layer under the tiles discreetly, without changing the structure or the tiles.

Many studies have been performed in order to evaluate the thermal behavior of solar energy recovery systems on pitched roofs. Garcia Valladares et al. (2008) have set an outdoor method test to determine the thermal behavior of a solar domestic water heating systems. Thur et al. (2006) have studied the energy savings for solar heating systems compared to fuel-oil and gaz boilers. Based on experimental investigations, they showed that the energy savings is around 10 kWh/m².an for a one-family house of 180 m² in Denmark. Yumurtas and Unsal (2012) have presented a hybrid analytical and computational model for finding the performance of solar assisted house heating systems utilizing a heat pump and an underground thermal energy storage tank.

In this paper, a modelling approach based on the assembly of zonal and nodal models, coupled with CFD results, is used to simulate the thermal and aerodynamic behaviour of the roof and its surrounding. The objective of this work is to predict the thermal behaviour of the air layer under the tiles, and to use it as the heat source of a thermodynamic water heater. The model permits to assess the annual gain of this system compared to a thermodynamic water heater using ambient air as heat source. An experimental apparatus is built, permitting to validate the model.

DESCRIPTION OF THE TEST BENCH

An experimental apparatus was built in order to evaluate the impact of different climatic configurations on the air layer under the tiles of a pitched roof. Figure 1 present a scheme of the experimental apparatus. The main components of the experimental set up are : (i) the inclined pitched roof composed of eight ranks of six tiles supported by batten and counter-batten all set on an insulated underlay. (ii) An air collector designed and installed in the air layer. This collector permits to intake the air under the tiles with the help of a fan; (iii) A heating lamp system set above the tiles. (iv) A ventilator simulating artificial conditions of speed wind and orientation. Figure 2 shows the photo of the test bench.

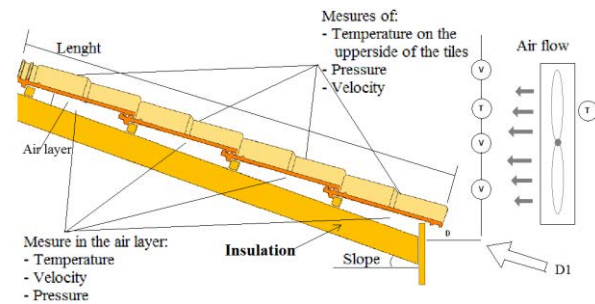

Figure 1 Schematic representation of the test bench

For artificial test conditions, a ventilator is used to simulate different wind velocity and orientation, and a set of lamps are installed above the tiles simulating the sun irradiations. The lamps used are UV heat lamps supplying a radiation flux of 70 W each. For natural test conditions, the test bench was installed in open air.



Figure 2 Photo of the experimental apparatus

The experimental apparatus is equipped with sensors to measure:

- Temperature of the upper side and lower side of the tiles, the air temperature in the layer under the tiles, the ambient air and the air temperature in the air collector;
- Air static pressure in the air layer, at the upper side of the tiles and in the air collector after exiting the air layer;
- Air velocity around the experimental apparatus and in the air layer;
- Extracted air flow rate from the air layer
- The lamps irradiation
- A weather station is set to measure the climatic conditions such as the ambient temperature, relative humidity, the sun irradiation, wind speed and orientation in the natural conditions tests.

A first set of experimental configurations allowed correlating the internal convective heat exchange coefficient and the air permeability of the roof.

OUTLINE OF THE NUMERICAL SIMULATION MODEL

A modelling approach based on the assembly of zonal and nodal models, coupled with CFD results, is used to simulate the thermal and air flow phenomena in the air layer under the pitched tiles (Roy et al., 2001). The numerical model allows first to evaluate the thermal behaviour of the air inside the air layer and then to estimate the potential of energy recovery for heating purposes, under realistic climatic conditions.

Thermal modelling of the pitched roof

In order to evaluate thermal behaviour of the air layer by numerical approach, it is necessary to model the air layer, the roof and its surroundings.

The detailed geometry of the tiles is introduced into the CFD, in order to take into consideration the aerodynamic behaviour of the air in the air layer and around the roof. For numerical reasons and because of scale difference, two models were developed in CFD; the first one takes into consideration the outlines of the roof and a large air volume around it (figure 3). In this model, the wind velocity and orientation are the boundary conditions leading to a function of static pressure acting on the upper side of the tiles. These correlations are then be introduced in the second CFD model as boundary conditions.

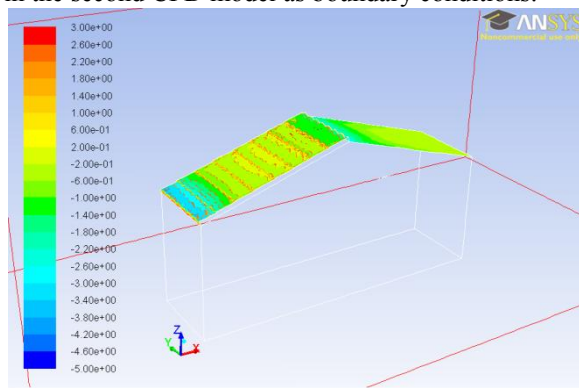

Figure 3- CFD model representing the roof outlines and the air around

The second CFD model studies the aerodynamic behaviour of the pitched roof and the air layer. A conventional roof consisting of the insulation and underlay (1) supporting counter-battens (2) supporting battens (3); supporting elements coverage, such as tiles (4) are drawn. Figure 4 shows the roof structure represented on Gambit software. The domaine between the tiles and the uderlay form the air volume, called the air layer. In this model, the air layer is divided into eight zones, where the mean air velocities in the air layer, and the infiltrated air through the tiles, from one zone to the other are calculated.

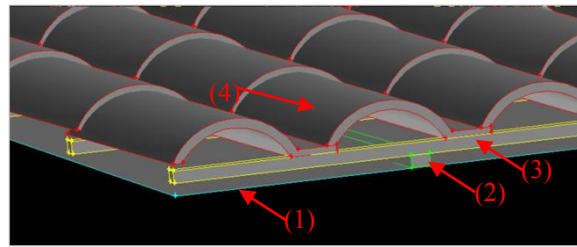

Figure 4 Geometry representing the roof and the air layer

Finally, the CFD results are used as boundary conditions in the software THERMETTE® (Roy et al., 2001) where the energy balance is solved for the different zones and components of the roof.

As results, the air temperature exiting the air layer through the collector is calculated all over the year. This temperature will then be used as an input for an air to water heat pump model used for the production of domestic hot water. The heat pump is modelled using the software Dymola. The object of this model is to calculate the annual energy saving of the thermodynamics hot water system production using the air layer as a heat source instead of ambient air.

MODEL ASSEMBLY APPROACH

The roof thermal behaviour model is based not only on energy balance equations for the air layer but takes into account the convective (forced), conductive (in the different bodies), irradiative (shortwave and long wave radiation outside and inside the air layer) and air flow transfer (through the zones) phenomena.

The zonal model uncouples heat transfer problem from air flow problem (no temperature-dependent properties or buoyancy forces). Based on this assumption the velocity fields and the air flow rates between zones are determined using Fluent regardless of boundaries and volumes temperatures. Velocity fields and air flow rate inter-zones are then introduced as entries to be set in Thermette® code.

The numerical methodology used is a typical approach known as software assembly, using several simulation codes independent from each other. Each software allows the calculation of the parameters intervening to answer a precise purpose:

- The calculation of the static pressure for a wind speed configuration is determined in the first CFD model using Fluent.
- The calculation of the air flows between zones, the air infiltration through the tiles and the velocity profiles in the air layer are determined using a small scale Fluent model,
- The coupling of heat (conductive, convective, radiative) and mass transfers, are carried out by the thermal software solver Thermette®.
- Modelling of the heat pump is finally realised in Dymola. It collects the temperature of the air

layer from the thermal model and calculate the energy savings of the system.

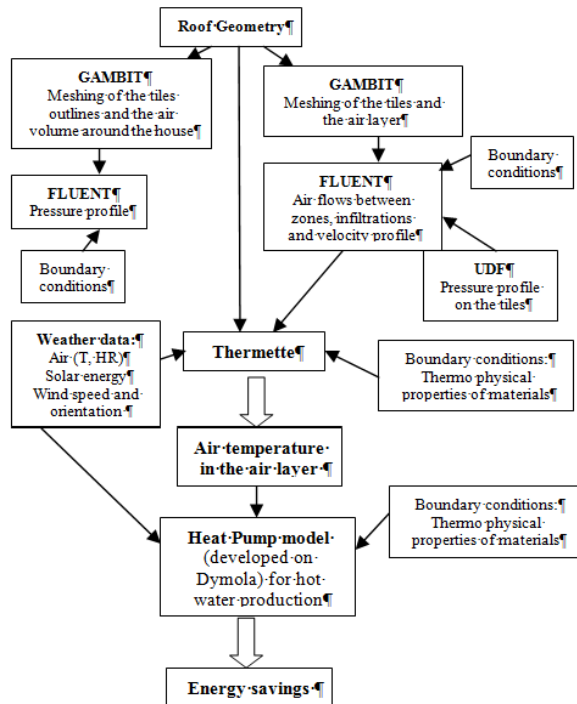

Figure 5 Model structure flowchart

Aerodynamic CFD representation

The aerodynamic simulation permits to describe the flow in the air layer. But the CFD requires very long computational time to simulate transient conditions such as heating phases of the roof.

Therefore studies that have been conducted with the code Fluent deals only with aerualics. Thermal study is decoupled and processed by the code THERMETTE. The equations for the description of the flow field are the equations of mass conservation and momentum. Knowing the boundary conditions, the resulting flow is determined by solving the Navier-Stokes equations:

$$\frac{\partial \rho}{\partial t} + \frac{\partial}{\partial x_i} (\rho u_i) = 0 \quad (1)$$

$$\frac{\partial}{\partial t} (\rho u_i) + \frac{\partial}{\partial x_i} (\rho u_i u_j) = - \frac{\partial p}{\partial x_i} + \frac{\partial}{\partial x_j} \left[\mu \left(\frac{\partial u_i}{\partial x_j} + \frac{\partial u_j}{\partial x_i} \right) \right] + \rho g_i \quad (2)$$

An analytical solution for a 3D partial differential equations of a turbulent flow is impossible. The use of a numerical method is essential, so the calculation requires the discretization of the flow field in time and space. Steady discretization is carried out only in space.

The finite volume method associated with the algorithm "Simple C" is used by the Software Fluent to obtain the numerical solutions. The discretized equations represent the flow in each control volume.

1. Boundary conditions of first CFD model

The design and meshing of the geometry realized in Gambit is exported to Fluent. The boundary conditions imposed to the model are presented below:

- The wind speed and direction, on one or more surfaces of the air volume.
- The roof is considered as a wall, where the static pressure generated by the wind is calculated
- Air pressure on the front section of the air layer is also calculated.
- Atmospheric pressure is set on the sides of the air volume where no wind conditions are imposed.

2. Boundary conditions of Second CFD model

The design and meshing of the geometry realized in Gambit is exported to Fluent. The boundary conditions imposed to the model are presented below:

- The impact of the wind is represented by the pressure on the upper surface of the tiles and on the front section of the air layer. These data are the result of the calculation made in the first CFD model, and introduced in the second one through a UDF (user defined function);
- The top section of the air layer is considered closed (wall);
- The tiles are considered as solid porous medium with a permeability "C2 = 204,300" determined experimentally;
- Air layer under the tiles: fluid (air);
- The battens, rafters and counter-battens are solid volumes, removed from the total volume; Software Fluent takes into account only the sidewalls of the battens and rafters.

3. Calculation model

Standard k-ε model is selected to model the turbulence and the standard "y⁺" law is used to represent the flow on the wall side. K-ε model is also known as the two-equations model (equations of k and ε) reflects the turbulence and is valid only in regions where the turbulence is dominant.

The flow is laminar within the walls due to the no slip boundary conditions. The flow is then calculated with a "law of wall" also called "y⁺" law. Convergence is obtained when the different residues (continuity, velocity in the x, y, z, k and ε) are lower than 10⁻³. Once the model has converged, the results can be considered valid.

4. Simulated configurations for the first CFD model

The simulated configurations aims to correlate the static pressure on the tiles according to the wind speed and orientation.

Three wind speeds are simulated, 2, 5 and 10 m/s, for three directions North, South and East.

The roof is tilted of 30° according to horizontal and is oriented to the south.

5. Simulated configurations for the second CFD model

Different configurations are simulated. The objective is to correlate the air infiltrations through the tiles and the flow rates from one zone to another depending on the wind speed and direction.

The calculations are performed for all nine configurations simulated in the first model.

The elaborated correlation will be used later in the thermal model in order to calculate for each step time the infiltrated air as a function of the wind velocity and orientation.

Thermette representation

The roof representation consists of several branches (1 D elements) and volumes (0D elements). The solid walls and elements are represented by branches, while respecting the various layers. The volume of the air layer is divided into 16 sub volumes considered at uniform temperature. These volumes are those who exchange heat with the tiles and allow determining the air supply temperature depending on the weather conditions and the sucked airflow rate. This simplified representation of the roof implies certainly several geometrical and physical assumptions to be considered:

- Temperature of the solid bodies varies in one dimension (1D element); from the outside to the inside.
- Temperature of air volumes is uniform (0D element)
- Thermo physical properties of the tiles are supposed to be independent of the temperature.
- Air thermo physical properties vary with the temperature and correspond to those of dry air.
- Air is transparent to radiation
- Radiative heat transfer occur between the upper side of the tiles and the sky
- Thermal emissivity of surfaces is constant.

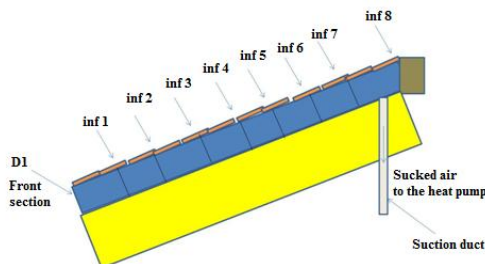

Figure 6 Simplified representation of the roof

The air flows into the air volumes (D1) through the front section and mix with the airflow rate (inf i) infiltrated or exfiltrated between two sets of tiles. The mixture flows in the air layer toward the next zones, as shown in figure 6 below.

Energy and mass balance is applied on each zone, and for every element.

1. Energy balance on the tiles

The tiles are modelled in an unsteady state. The general equation governing heat transfer inside and at the boundary limits of 1D branch is described in the following equation (x is the abscissa in the direction of the thickness of the tile).

$$\lambda \frac{d^2 T}{dx^2} = \rho c \frac{\partial T}{\partial t} \quad (3)$$

The term on the right represents the internal energy increase rate. On the left, the term represents the conduction inside the 1D branch.

This equation has two boundary conditions;

- At the upper side of the tiles, convection with ambient air, solar irradiation and radiation to the sky.

$$-\lambda \left. \frac{\partial T}{\partial x} \right|_{x=0} = Q_{sol, norm} \times \varepsilon_{tiles} + \varepsilon_{tiles} \times \sigma \cdot (T_{sky}^4 - T^4) + h_{ext} \cdot (T_{air, amb} - T) \quad (4)$$

- At the inner side of the tiles; convection with the air layer, radiation between the surfaces

$$-\lambda \left. \frac{\partial T}{\partial x} \right|_{x=e} = r \times \sigma \cdot (T_{int, surface}^4 - T^4) + h_{int} \cdot (T_{air, volume} - T) \quad (5)$$

Where r is the radiative transfer factor between the tiles and the inner wall calculated following the equation (6);

$$1/r = 1/\varepsilon_{tiles} + 1/\varepsilon_{int, surface} - 1 \quad (6)$$

2. Energy and mass balance in the air volumes (0D)

The mass and energy balance is written at the inlet of each volume in order to determine the airflow rate circulating in the air layer through the front section of the considered volume, as well as the air temperature at inlet.

At the inlet of every volume, the mass flow rate and the temperature of the air is expressed as following:

$$D_i = D_{i-1} + Inf_{i-1} \quad (7)$$

$$T_{air,in,i} = \frac{D_{i-1} \cdot T_{air,out,i-1} + Inf_{i-1} \cdot T_{air,amb}}{D_i} \quad (8)$$

The energy balance equation applied on the volume of air, exchanging heat with the inner side of the tiles and the underlay surface, can be written as follow:

$$\begin{aligned} h_{int} \cdot (T_{tiles,int} - \overline{T_{air,i}}) + h_{int} \cdot (T_{underlay,int} - \overline{T_{air,i}}) \\ = \frac{D_i}{A} C_{p,air} \cdot (T_{air,out,in} - T_{air,in,i}) \end{aligned} \quad (9)$$

“A” is the contact area between the tiles and the underlay surface with the air volume (i), and;

$$\overline{T_{air,i}} = \frac{T_{air,in,i} + T_{air,out,i}}{2} \quad (10)$$

The energy balance equation applied on the insulated underlay surface can be written as follow:

$$\begin{aligned} r\sigma \cdot (T_{underlay,int}^4 - T_{tiles,int}^4) \\ + h_{int} \cdot (T_{underlay,int} - \overline{T_{air}}) \\ = 0 \end{aligned} \quad (10)$$

Dymola representation

A dynamic model of a heat pump for hot water production is realised using Dymola. This software uses the Modelica language. It is an acausal language based on multi-physical modelling. The model is that of a single-stage compression heat pump operating with the refrigerant R134a. The thermodynamic water heater is modelled in the environment Dymola by assembling the components constituting the thermodynamic cycle of the heat pump. The refrigeration cycle modelled in Dymola is presented in figure 7.

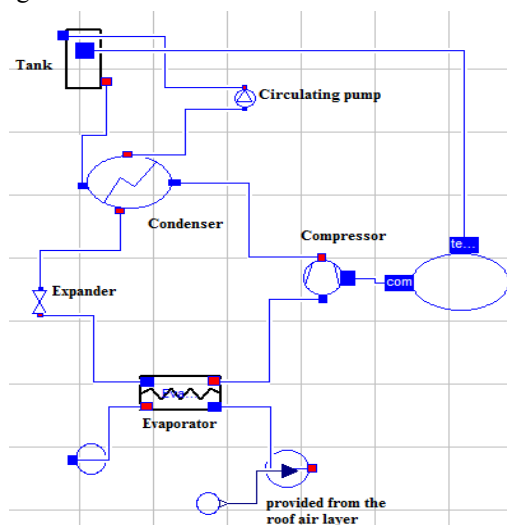

Figure 7 Heat pump components modeled on Dymola

The condenser and the evaporator are two heat exchangers modeled by setting a pinch of 5 K between the fluids.

The evolution of the refrigerant in the expander is isenthalpic.

The heat pump compressor is a rotary compressor with fixed speed (50 Hz). Efficiency values are set according to the data sheet of a thermodynamic water heater available on the market.

- Volumetric efficiency of 0.917

- Isentropic efficiency of 0.763

- Effective isentropic efficiency of 0.763

The volume of hot water is 270 L. It is controlled to heat the water to 60 ° C and to operate when the temperature of the air layer is hotter than ambient air, implying operation from 11 am.

Each element is modeled independently and integrated into the overall model by Fluid connectors (characterized by pressure, enthalpy and mass flow rate) and Air (characterized by a temperature and mass flow). Equations for each element are based on heat and mass conservation.

The thermodynamic system is an air source heat pump. At low temperatures and high humidity, external battery is subject to frost deposits. Thus, the system operates in defrost mode and loses performance. In order to take into consideration these losses, the performance degradation is correlated as function of external temperature and is taken into consideration in the thermodynamic model of the heat pump (Maatouk et al. 2010).

RESULTS AND DISCUSSION

As a first step, calculations were performed using as input data the test conditions operating in artificial and natural state. This enabled the validation of the numerical thermal model. Then, simulations are performed over a year considering the weather in different cities in France. The objective is to calculate the temperature of the air sucked under the tiles. This heated air is used as a heat source for a heat pump water heater. Finally, the modelled heat pump and storage tank will help calculating the annual consumption of the thermodynamic water heater operating with ambient air and compare it to that operating with heated air captured under the tiles. Finally, the gain brought by this technology to capture energy under the tiles is evaluated.

Validation of the thermal model

The experimental set up was first operated with artificial conditions, ie to control all the boundary conditions acting on it. The ventilator at different speeds blew a constant airflow, simulating the wind. Infrared lamps installed over the tiles simulate solar

radiation. These boundary conditions were set in the model and simulated. Figure 8 shows the comparison between the measured and simulated values. The model reproduces well the dynamic thermal behaviour of the roof and the air layer in artificial conditions.

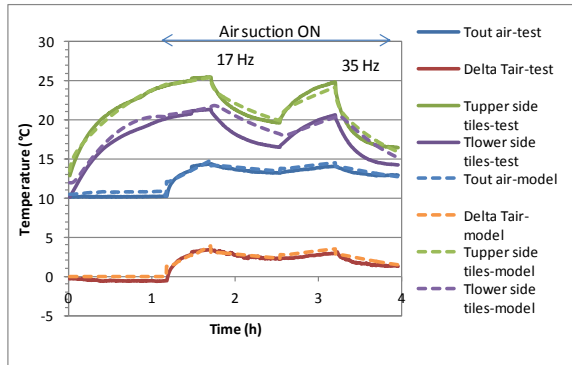

Figure 8 Evolution of calculated and measured temperatures in artificial test conditions

In a second step, the experimental device is installed outdoor in a natural environment where it undergoes variable climatic conditions depending on the day and the weather.

The measured weather conditions were set in the model as boundary conditions. Figure 9 shows the comparison between simulated and measured data. The obtained results show that a relative error of $\pm 10\%$ is calculated between the measures and the simulation, and can be considered as acceptable.

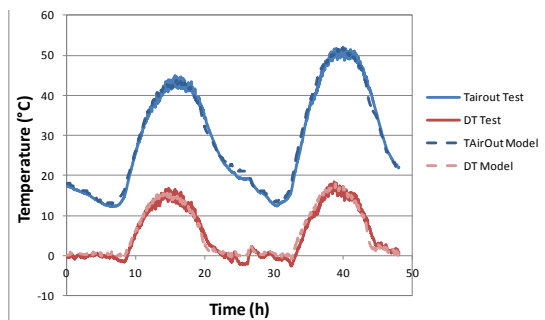

Figure 9 Evolution of calculated and measured collected air temperatures in natural test conditions (DT is defined as the difference between collected air and ambient temperature)

Heating potential of one year

The calculation is performed on a full year. Five representative cities of the French climate are chosen for thermal simulation. The hourly meteorological data was obtained from the software Meteonorm, and used, specifically:

- Temperature and relative humidity of the air;
- The wind speed and direction;
- The direct solar flux.

In this paper, only the results of the city of Bordeaux are presented. However, the trend for the other cities

(Toulouse, Nice, Nancy and Trappes) is similar to the results obtained for Bordeaux.

For this simulation, it is assumed that the air is continuously sucked under the tiles. The on-off scenario for the fan is not introduced. The calculated air layer temperature is used in the thermodynamic water heater model. Figure 10 presents the calculation results for the collected air, which is compared to the ambient temperature. It shows that the ambient air source is heated up to 20 K before it is used in the thermodynamic water heater.

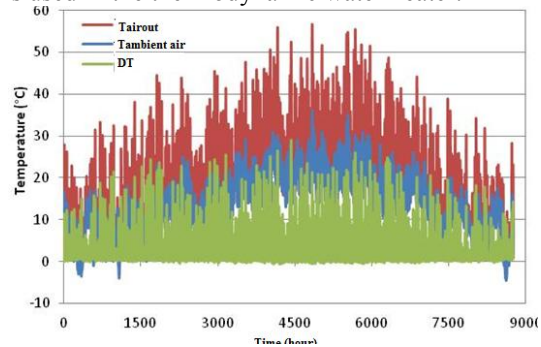

Figure 10 Evolution of calculated temperatures for the city of Bordeaux

In the heat pump model, the air source at the evaporator used for the reference simulations is the ambient air temperature then the calculated air temperature in the air layer under the tiles.

Energy consumption of the thermodynamic water heater and annual gain

The calculations are performed for a full year. The computing time step is 360 seconds. Three calculations are performed:

- Night operating period, using ambient air as heat source
- Daily operating period, using ambient air as heat source
- Daily operating period, using air under the tiles as heat source

Electrical consumptions considered in the model are:

- The power consumption of the compressor
- The consumption of the circulation pump water
- The power consumption of the fan, taking into account the extra pressure drop generated by the intake and discharge ducts
- Energy losses related to frost/defrost cycles of the system.

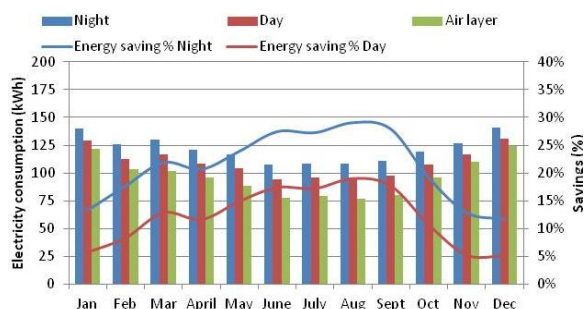

Figure 11 Monthly energy consumption and savings

Figure 11 shows the monthly electrical consumption of the thermodynamic water heater. The figure presents also the energy savings achieved when the air layer under tiles is used compared to daily or night operating periods.

The annual electricity consumption of the system, operating with recovered heated air under the tiles are reduced, compared to conventional systems. Energy savings of 26% and 13% are respectively calculated for night and day operating periods.

CONCLUSIONS

This paper has shown the potential of heat recovery from the air under the tiles of a pitched roof. The aerodynamic and thermal behavior of a pitched roof was evaluated by mean of coupled simulations between thermal simulation and Computational Fluid Dynamics. Simulation results were validated experimentally by the mean of an experimental set up built and tested under different weather conditions. Model has shown good agreement with the experimental results. Finally a thermodynamic water heat was modeled on Dymola. available energy in the air layer is valorized and used as heat source for the heat pump. Results show that the valorization of this energy can reduce the annual energy consumption of a single family house for about 26%.

NOMENCLATURE

A	surface area	m^2
C	heat capacity	$J/(kg.K)$
D	mass flow rate	kg/s
g	gravity	m/s^2
h	convective heat exchange coefficient	$W/(m^2.K)$
inf	infiltrated air mass flowrate	kg/s
Q	heat exchange	W
r	distance	m
T	temperature	K ou $^{\circ}C$
t	time	s
u	velocity component	m/s

Subscripts

Δ	variation
amb	ambient
c	convective
ext	exterior
int	interior
sol	sun
norm	normal

Greek symbols

ϵ	Emissivity	
λ	Conductivity	$W/(m.K)$
μ	Viscosity	$Pa.s$
ρ	Density	kg/m^3

σ Stefan–Boltzmann constant
 $W/(m^2.K^4)$

ACKNOWLEDGEMENT

The authors would like to acknowledge TERREAL R&D for its support during this project.

REFERENCES

- Belusko M., Saman W., Bruno F. 2004. Roof integrated solar heating system with glazed collector. *Solar Energy*, 76 (2004) 61-69.
- Garcı Valladares, Pilatowsk, Ruiz , 2008. Outdoor test method to determine the thermal behavior of solar domestic water heating systems. *Solar Energy*, 82 (2008) 613-622
- International Energy Agency. 2011. "Solar Energy Perspectives: Executive Summary".
- CEA, 2012. Question de physique autour de l'énergie solaire". Séminaire Questions de Sciences, 6 juin 2012.
- Roy. D. et al.2001 Modeling of In-Vehicle heat transfers using zonal approach, *Proceedings of SAE 2001*, 5-8 March 2001.
- Jinqing et al., 2013. Review on life cycle assessment of energy payback and greenhouse gas emission of solar photovoltaic systems. *Renewable and Sustainable Energy Reviews*, 19 (2013) 255–274
- Maatouk et al., 2010. New Methodology of Characterization of Seasonal Performance Factor of An Air-To-Water Heat Pump. *Proceedings of Purdue Compressor Engineering, Refrigeration and Air Conditioning and High Performance Buildings Conferences*, 2010.
- Sidiras Dimitrios, and Koukios Emmanuel, 2005. The effect of payback time on solar hot water systems diffusion: the case of Greece. *Energy Conversion and Management* 46 (2005) 269–280.
- SolTech Energy, 2011. Free heating and cooling from the sun. <http://soltechenergy.com/soltech-flex/>
- Stag Viessman; 2009. Heating with solar energy. <http://www.viessmann.fi/etc/medialib/internet-fi/pdf/products.Par.8744.File.File.tmp/Heatingwithsolarenergy.pdf>
- Thür Alexander, Furbo Simon, Shah Louise Jivan, 2006. Energy savings for solar heating systems. *Solar Energy*, 80 (2006) 1463-1474.
- Yumrutas Recep, Ünsal Mazhar, 2012. Energy analysis and modeling of a solar assisted house heating system with a heat pump and an underground energy storage tank. *Solar Energy*, 86 (2012) 983-993.